





CONVEYOR ROLLERS
ROLLERDRIVE
DRIVECONTROLS

DRIVE CONCEPTS

TABLE OF CONTENTS

				Gravity	Flat belt	Round belt	Chain	Toothed belt	PolyVee Belts	
Products for lightweight materials to be transported	Conveyor Rollers	Series 1100	p 12	✓						
		Series 1500	p 16	✓	✓					
		Series 1700 light	p 18	✓	✓					
		Series 3500KXO light	p 22	✓		✓				
Products for medium-heavy materials to be transported	Conveyor Rollers	Series 1100	p 28	✓						
		Series 1200	p 32	✓	✓					
		Series 1500	p 36	✓	✓					
		Series 1700	p 38	✓	✓	✓				
		Series 1700KXO	p 46	✓	✓	✓				
		Series 3500	p 50		✓	✓	✓	✓	✓	
		Series 3500KXO	p 58			✓	✓		✓	
		Series 3560	p 62				✓			
		Series 3800	p 66				✓	✓		
		Series 3860	p 74				✓			
		Series 3870	p 78				✓			
		RollerDrive	BT100	p 88			✓			✓
			EC310	p 92			✓		✓	✓
			EC310 refrigerated app.	p 92			✓			✓
EC310 IP66	p 100				✓		✓	✓		
Products for heavy materials to be transported	Conveyor Rollers	Series 1450	p 120	✓						
		Series 3560	p 124				✓			
		Series 3600	p 128				✓	✓		
		Series 3950	p 132				✓			
Other Conveyor Elements and Accessories	Pressure Rollers	Series 2600	p 138		✓	✓				
		Ball Transfer Units	Series 5500	p 140	✓					
	Conveyor Wheels	Series 5000	p 144	✓						
		Series 2130	p 148	✓						
		Series 2370	p 150	✓						
		Series 2200	p 152	✓						
	OmniWheels	Series 2500	p 154	✓						
		Series 2800	p 156	✓						
	Roller Tracks	Series BU40	p 158	✓						
		Series BU50	p 160	✓						
Series Floway		p 162	✓							
DriveControls	Controls for RollerDrive	DriveControl 20	p 106							
		DriveControl 54	p 108							
		ZoneControl	p 110							

	Page
Interroll worldwide	2
Interroll's Intralogistics	4
Interroll Product Overview	6
Solutions for Lightweight Materials to be Transported 	8
Conveyor Rollers	10
Solutions for Medium-Heavy Materials to be Transported 	24
Conveyor Rollers	26
Magnetic Speed Controller 50	82
RollerDrive	86
DriveControls	104
Solutions for Heavy Materials to be Transported 	116
Conveyor Rollers	118
Other Conveyor Elements and Accessories	136
Pressure Rollers	138
Ball Transfer Units	140
Conveyor Wheels	148
OmniWheels	154
Roller Tracks	158
Planning Section	170
Material Specification	226

The Worldwide Interroll Group

The Interroll Group is one of the world's leading specialists for internal logistics.

The company, which is listed on the stock exchange and has its headquarters in Switzerland, employs some 1,800 people in 31 companies around the globe.



Our products can be found primarily in the food industry, in airport logistics, in the parcel, postal and courier sector, in distribution, and in various branches of the industry. This includes: Easy-to-integrate drive solutions such as drum motors for belt conveyors; conveyor rollers and DC drive rollers for roller conveyors; flow storage modules for compact pallet and container storage in distribution centers; crossbelt sorters, belt curves and other user-friendly conveyor modules for cost-efficient material flow systems.

With the acquisition of Portec in 2013, Interroll increases its customer presence and offers a greater product range in the airport and package sectors.

Among the 23,000 Interroll customers overall are plant constructors, system integrators and equipment manufacturers. Our products are in daily use at brands known throughout the world, such as Amazon, Bosch, Coca-Cola, Coop, DHL, Procter & Gamble, Siemens, Walmart, Yamaha, and Zalando.

Regional Centers of Excellence and production, global knowhow, financial stability and a solid market reputation make Interroll the strong business partner and attractive employer.

Furthermore, Interroll initiates global research projects in the logistics efficiency sector, and actively supports industry associations in the development of standards and in the more efficient utilization of resources.

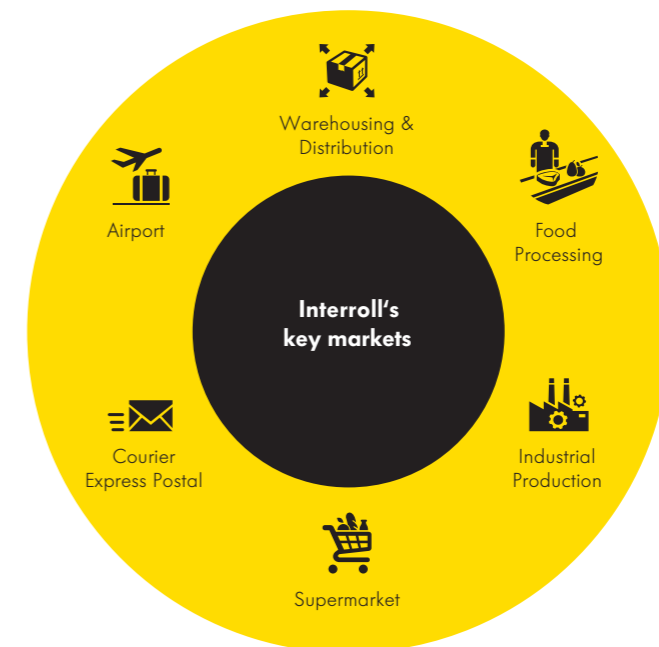

The Heart of Internal Logistics

With an experienced eye for the big picture, we offer you products that are versatile and essential building blocks in the portfolio of any successful planner or developer.

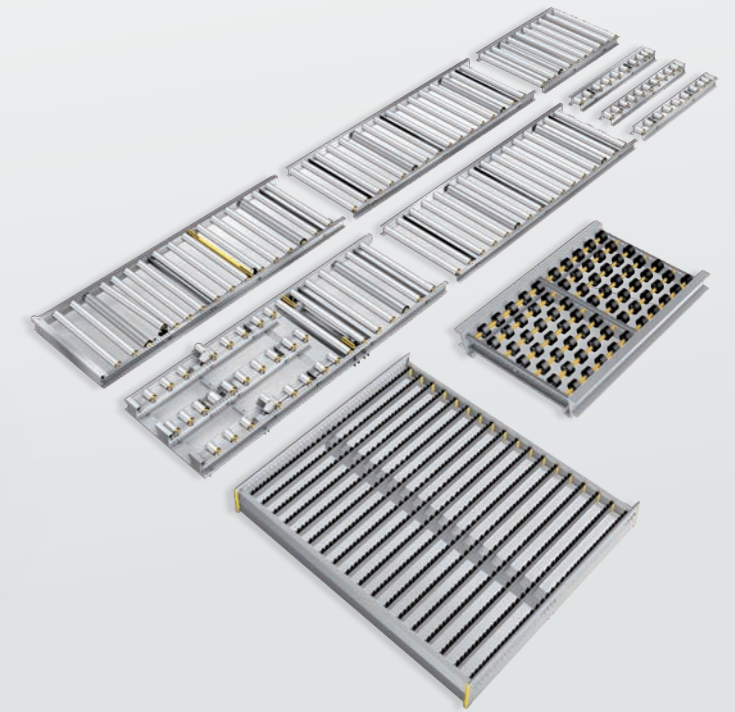

Conveying

Versatile and reliable core products ensure a dynamic, efficient material flow across all continents and in all industries:

- Conveyor Rollers
- Drum motors and idler pulleys
- 24 V drives (RollerDrive)
- Controllers for RollerDrive and drum motors

They are used to convey, accumulate, feed or remove goods. Powered or with the force of gravity. With or without dynamic pressure. Easy-to-install drive solutions for new plants or for refurbishing existing plants. Excellent products that will pay for themselves and that you can rely on. In every respect.

Transporting and distributing

Millions of different individual items travel through the world's flow of goods every day and must be delivered on time to the correct destination. This is a trend that requires a performance-based logistics system with efficient material flow systems. Interroll's innovative conveyor modules and subsystems are always ready for key locations in customers' systems:

- Crossbelt sorters
- Belt curves and belt merges
- Conveyor modules with zero-pressure accumulation
- Roller conveyors
- Belt conveyors

Precisely pre-assembled and rapidly delivered for fast, simple integration into the complete system on site (plug and play). The conveyor modules and subsystems provide users with key assurances: excellent availability whilst being easy to use; outstanding efficiency even at low throughput volumes; efficient investment with a short period of return on investment; adaptability in the event of change.

Storage and picking

Economical and user-friendly: the dynamic storage solution that operates without power. It is designed for fast-moving goods (e.g. groceries) that have to be quickly picked and immediately conveyed to consumers. The principle is as simple as it is ingenious. It is known as FIFO, First in – First out, and guarantees that what has been stored first is also picked first. Or LIFO, Last in – First out, when what has been stored last is picked first. It means making maximum use of minimum space. And because the needs of our customers are as diverse as their products, our central and peripheral subsystems offer unlimited design options.

- Pallet Flow
- Carton Flow

The picking times can scarcely be beaten. The return on investment for the operator is two to three years and is integrated into "Just in Time".

INTERROLL – THE MOST GLOBAL PROVIDER OF KEY PRODUCTS FOR MATERIAL HANDLING SOLUTIONS



- ① FIFO - Pallet flow storage modules (Conveyor Rollers)
- ② LIFO - Pallet flow storage modules (Conveyor Rollers)
- ③ LIFO - Pallet flow storage modules (Cart Pushback)
- ④ Order picking racking with Carton Flow (Roller Track)
- ⑤ Order picking racking with Flex Flow

- ⑥ Drum Motors, Idler Pulleys, brackets
- ⑦ 24 V DC RollerDrive and Controls
- ⑧ Conveyor Rollers and Accessories
- ⑨ Idler Pulleys

- ⑩ Crossbelt Sorters
- ⑪ Belt Curves
- ⑫ Belt Conveyor Modules
- ⑬ Intellivoyor Modules for zero pressure accumulation (ZPA) Conveyors

Interroll Solutions
for Lightweight Materials to be Transported p 8
for Medium-Heavy Materials to be Transported p 24
for Heavy Materials to be Transported p 116



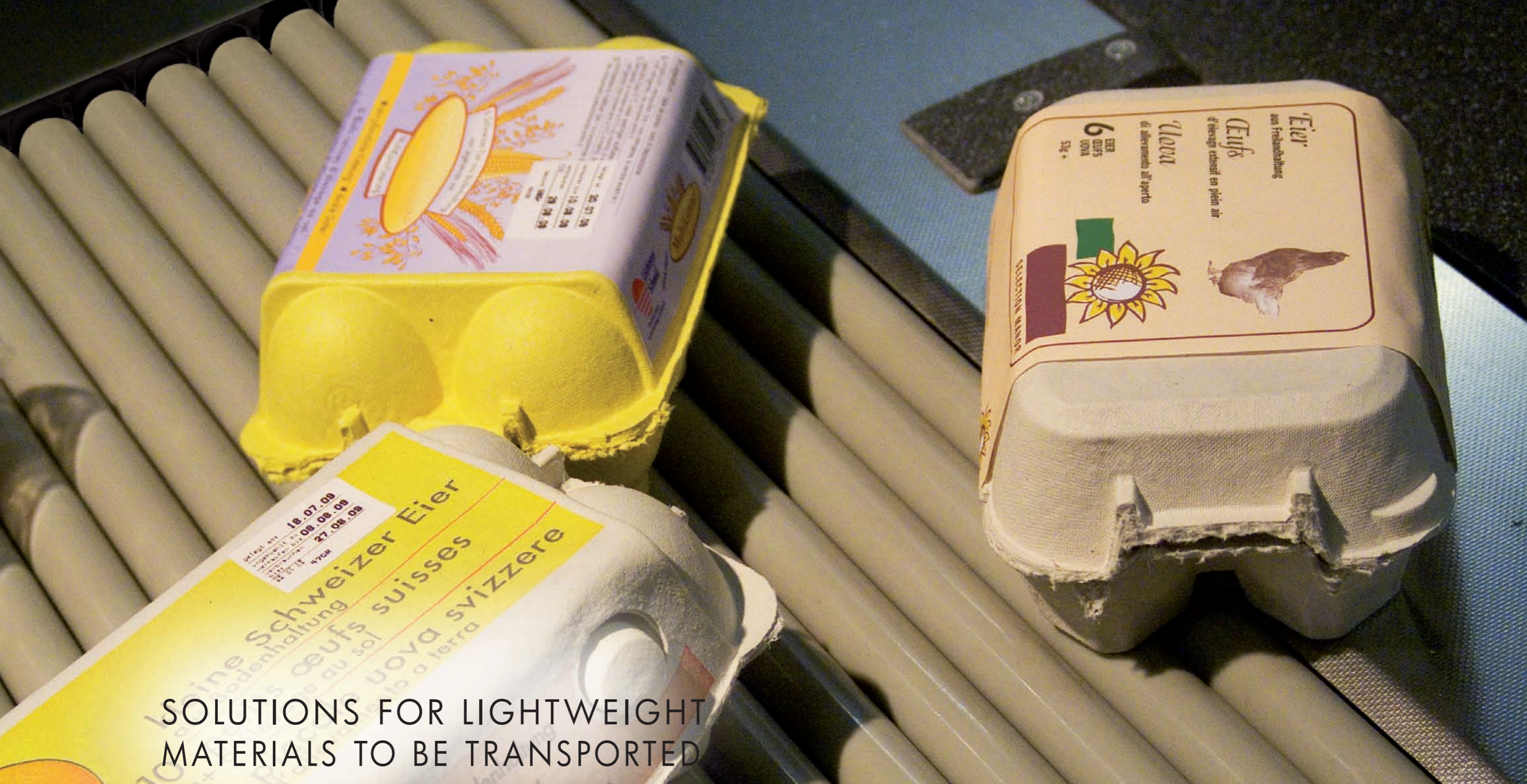

SOLUTIONS FOR LIGHTWEIGHT MATERIALS TO BE TRANSPORTED

With this product range, you can set up roller conveyors for lightweight, small and, to some extent, medium-heavy materials to be transported, for example for paper in a printing machine, for bottles, small containers for the pharmaceutical or beverage industries or small cardboard boxes in the packaging industry weighing up to 35 kg and at conveyor speeds of up to 1.5 m/s. The load capacity of these products is up to 350 N per conveyor roller.

Products for lightweight materials to be transported

Conveyor Rollers

The basis of every roller conveyor

p 10



OVERVIEW OF CONVEYOR ROLLERS

	Smooth-running Conveyor Roller Series 1100	Slide Bearing Conveyor Roller Series 1500	Lightweight Conveyor Roller Series 1700 light	Tapered Fixed Drive Conveyor Roller Series 3500KXO light
Max. load capacity	350 N	120 N	150 N	150 N
Applications	Gravity	Moist area	Universal	Fixed drive curve
Drive concepts				
Gravity	✓	✓	✓	✓
Flat belt		✓	✓	
Round belt				✓
Chain				
Toothed belt				
PolyVee belt				
	see page 12	see page 16	see page 18	see page 22



SMOOTH-RUNNING CONVEYOR ROLLER SERIES 1100



Conveyor Rollers
Gravity
Series 1100

The gravity roller with optimised light start-up

Product Description

- Customer benefits**
 - Cost-effective, corrosion-proof gravity roller
 - Use of stainless steel balls
 - Gentle lateral pushing of the materials to be conveyed
 - Rounded tube ends
 - Protects the bearing from coarse dirt and liquids
 - Integral water-repellent groove
 - Resistant to dirt
 - Smooth surfaces
- Applications**
 - In-house conveyor technology
 - Only gravity applications
- Properties**
 - Silent, precise smooth-running roller due to special steel ball bearings and tube made of polypropylene.
 - Form-fit join of the bearing housing with the tube above a diameter of 30 mm to avoid slipping of the bearing seat.
- Associated platform**
 - Platform 1100

Technical Data

General technical data	
Max. load capacity	350 N
Max. conveyor speed	0.3 m/s
Temperature range	-5 to +40 °C
Materials	
Bearing housing	Polypropylene
Seal	Polypropylene
Ball	Carbon steel or stainless steel 1.4301

The dynamic load and the surface load are the assumptions for the load capacity. The shaft version can be selected at will.

Load capacity

Tube material	Ø Tube mm	Ø Shaft mm	Max. load capacity in N with an installation length of mm												
			100	200	300	400	500	600	700	800	900	1,000	1,100	1,200	
PVC	16 x 1.0	5	33	7	3	2	-	-	-	-	-	-	-	-	
	20 x 1.5	6	90	20	10	5	-	-	-	-	-	-	-	-	
	30 x 1.8	8	120	100	40	20	15	10	-	-	-	-	-	-	
	40 x 2.3	8	180	180	130	70	40	30	-	-	-	-	-	-	
	50 x 2.8	8/10	350	350	310	165	100	70	-	-	-	-	-	-	
Steel	16 x 1.0	5	50	50	50	50	-	-	-	-	-	-	-	-	
	20 x 1.5	6	90	90	90	90	90	90	90	-	-	-	-	-	
	50 x 1.5	10/12	350	350	350	350	350	350	350	350	350	350	350	350	
Aluminium	20 x 1.5	6	90	90	90	90	85	60	43	-	-	-	-	-	



SMOOTH-RUNNING CONVEYOR ROLLER SERIES 1100



Conveyor Rollers
Gravity
Series 1100

The gravity roller with optimised light start-up

Product Selection

Standards Spring-loaded shaft version

Material	Ø mm	Ball bearing	Shaft	Reference number		
			Ø 5 mm	Ø 6 mm	Ø 8 mm	Ø 10 mm
PVC	16 x 1.0	Stainless steel	1.1B5.S16.A50			
	20 x 1.5	Standard	1.1AZ.N21.D03			
	20 x 1.5	Stainless steel	1.1AZ.S20.D03			
	30 x 1.8	Standard	1.1DJ.S31.E03			
	30 x 1.8	Stainless steel	1.1DK.S31.G03			
	40 x 2.3	Standard	1.1DL.S40.E03			
	40 x 2.3	Stainless steel	1.1DM.S40.E03			
	50 x 2.8	Standard	1.1EJ.SAA.EAB	1.1EL.SAA.HAC		
	50 x 2.8	Stainless steel	1.1EK.SAA.GAB	1.1EM.SAA.KAC		
Steel, stainless steel	16 x 1.0	Stainless steel	1.1B5.N10.A50			
	20 x 1.5	Stainless steel	1.1AZ.N21.D03			
	50 x 1.5	Stainless steel	1.1ED.NAA.KAC			
Steel, zinc-plated	50 x 1.5	Standard	1.1EC.JAA.HAC			
Aluminium, anodised	20 x 1.5	Stainless steel	1.1AZ.A2D.D03			

Female threaded shaft version

Material	Ø mm	Ball bearing	Shaft	Reference number
			Ø 12 mm (M8 x 15)	
Steel, stainless steel	50 x 1.5	Stainless steel	1.1EF.NAA.MAS	
Steel, zinc-plated	50 x 1.5	Standard	1.1EE.JAA.LAE	

Ordering example Example of a reference number: 1.1EJ.SAA.EAB - 490

This reference number is for a Conveyor Roller Series 1100, PVC, Ø tube 50 mm, standard ball bearing, Ø shaft 8 mm, spring-loaded shaft and reference length 490 mm. The reference length RL can be found in the table of dimensions for spring-loaded shafts: $RL = EL - 10$. The axial play of 0.5 mm per side has already been taken into account. The nominal clearance of your conveyor is 500 mm, which also corresponds to the installation length EL, i. e. the reference length is: $500 - 10 = 490$ mm.

Dimensions

RL	Reference length/Ordering length*
EL	Installation length
AGL	Total length of shaft
F	Length of the bearing assembly, including axial play

*The reference length/ordering length RL does not have any reference edges on the conveyor roller and can therefore not be shown.

Dimensions for spring-loaded shaft

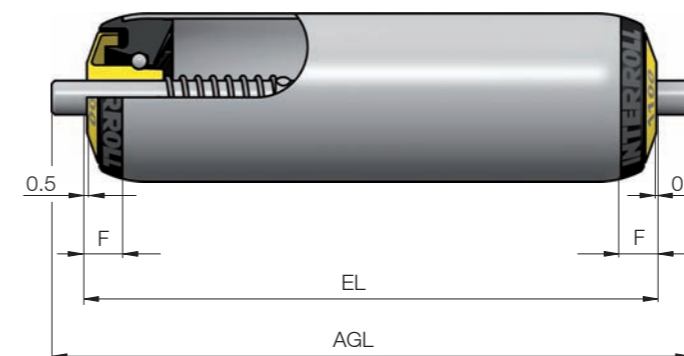

Ø Shaft mm	Ø Tube mm	RL mm	AGL mm	F mm
5	16	EL - 5	EL + 12	10.5
6	20	EL - 5	EL + 12	10.5
8	30	EL - 5	EL + 16	8.5
8	40	EL - 5	EL + 16	11
8	50	EL - 10	EL + 16	11
10	50	EL - 10	EL + 20	11

Dimensions for female threaded shaft M8 x 15

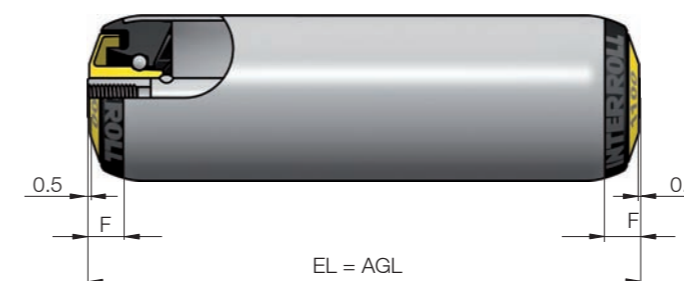

Ø Shaft mm	Ø Tube mm	RL mm	AGL mm	F mm
12	50	EL - 10	EL	11

Options

We can offer you the following options in addition to our standard products:

- Antistatic version
- Special surface finish for tubes
 - Hardened
 - Brushed stainless steel tubes
- Tube sleeves above Ø 30 mm
 - Flexible PVC sleeve
 - PU sleeve for Ø 50 mm
 - Rubber coating



SLIDE BEARING CONVEYOR ROLLER SERIES 1500



Conveyor Rollers
Moist area
Series 1500

Sealed, ideal for moist areas and to comply with hygiene requirements

Product Description

- Customer benefits**
- Slide bearing conveyor roller; suitable for cleaning with conventional detergents.
 - External slide bearing and pressed bearing housings, which prevent the penetration of foreign bodies into the inside of the roller
 - Corrosion-proof conveyor roller
 - Stainless steel shaft pin, PVC / stainless steel tubes, polypropylene bearing housing
 - Durable, smooth-running slide bearing conveyor roller
 - External, wear-resistant slide bearing made of POM + PTFE
- Applications**
- Food sector to comply with hygiene regulations
 - Moist area
 - Driven and non-driven container conveyor technology
 - Suitable for materials to be transported with a weight of 20 kg
- Properties**
- Slide bearing clip to snap into a profile with max. 2.5 mm wall thickness and hexagonal holes 11 mm (+0.3 / +0.8 mm)
 - Stainless steel shaft pins
 - Simple to remove slide bearing clip to insert and remove the conveyor rollers
- Associated platform**
- Platform 1500

Technical Data

General technical data

Max. load capacity	120 N
Max. conveyor speed	0.8 m/s
Temperature range	-10 to +40 °C

Materials

Bearing housing	Polypropylene
Shaft pin	Steel, stainless steel
Slide bearing	Polyoxymethylene

Load capacity The load capacity is affected by the length of the roller and by the dependent parameters of the weight of the material to be conveyed and the conveying speed.

The load capacity depends on the speed

Ø Tube mm	Speed m/s	Max. load capacity N
30	0.25	50
	0.80	40
50	0.25	120
	0.80	85

The load capacity depends on the reference length

Tube material	Ø Tube mm	Max. load capacity in N with an installation length of mm							
		100	200	300	400	500	600	700	800
PVC	30 x 1.8	50	50	35	20	12	-	-	-
	50 x 2.8	120	120	120	120	95	65	48	35
Steel	30 x 1.2	50	50	50	50	50	50	50	50
	50 x 1.5	120	120	120	120	120	120	120	120

Product Selection

Shaft pin shaft version

Tube Material	Ø mm	Bearing design	Shaft pin Ø 6 mm
PVC	30 x 1.8	Slide bearing	1.5AB.S3B.00C
	50 x 2.8	Slide bearing	1.5AF.SAA.00C
Steel, stainless steel	30 x 1.2	Slide bearing	1.5AA.N31.00C
	50 x 1.5	Slide bearing	1.5AE.NAA.00C
Steel, zinc-plated	30 x 1.2	Slide bearing	1.5AA.J31.00C
	50 x 1.5	Slide bearing	1.5AE.JAA.00C

Standards

Example of a reference number: 1.5AF.SAA.00C - 490

This reference number is for a Conveyor Roller Series 1500, PVC, Ø tube 50 mm, Ø shaft pin 6 mm and reference length 490 mm. The reference length RL can be found on the dimensioned drawing: $RL = EL - 10$. The axial play of 0.5 mm per side has already been taken into account. The nominal clearance of your conveyor is 500 mm, which also corresponds to the installation length EL, i. e. the reference length is: $500 - 10 = 490$ mm.

Ordering example

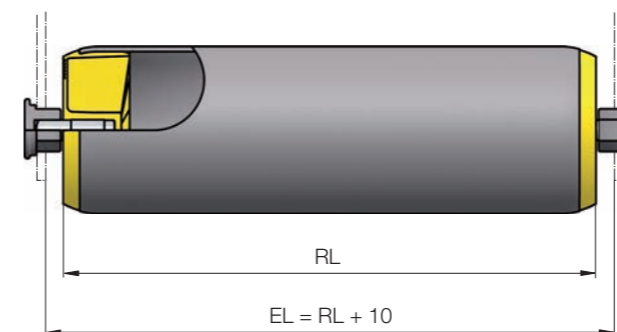

RL	Reference length/Ordering length
EL	Installation length

Dimensions

Options

We can offer you the following options in addition to our standard products:

- Tube sleeves
 - Flexible PVC sleeve
 - PU sleeve for Ø 50 mm
 - Rubber coating
- Special surface finish for tubes
 - Brushed stainless steel tubes



LIGHTWEIGHT CONVEYOR ROLLER SERIES 1700 LIGHT



Conveyor Rollers
Universal
Series 1700 light

Small diameter for smaller materials to be conveyed

Product Description

- Customer benefits**
 - Quiet conveyor roller with low energy requirement
 - Precision ball bearing, polymer bearing housing and seal
 - Complete range
 - Driven and non-driven conveyor rollers, rollers for curves
 - Axial loads are possible
 - Axial forces diverted by ball bearing
 - Small pitches are possible
 - Ø 20 mm and Ø 30 mm
- Applications**
 - In-house transport of smaller materials to be conveyed
 - Machine chains
 - Packaging industry
 - Automated assembly
- Properties**
 - Sealed precision ball bearing (689 2Z)
 - Rounded roller ends for simple lateral pushing
- Associated platform**
 - Platform 1700

Technical Data

General technical data	
Max. load capacity	150 N
Max. conveyor speed	1.5 m/s
Temperature range	-5 to +40 °C
Materials	
Bearing housing	Polyamide
Seal	Polypropylene
Ball bearing	Steel 689 2Z

Load capacity The load capacity depends on the length of the roller. The shaft version can be selected at will.

Material	Ø Tube mm	Max. load capacity in N with an installation length of mm					
		100	200	300	400	500	600
PVC	20 x 1.5	150	50	10	-	-	-
	30 x 1.8	150	150	60	20	10	-
Steel	20 x 1.5	150	150	150	150	150	150
	30 x 1.2	150	150	150	150	150	140

Product Selection

Spring-loaded shaft version

Material	Ø mm	Ball bearing	Shaft	
			Reference number Ø 6 mm	Ø 8 mm
PVC	20 x 1.5	689 2Z	1.72A.S20.BAC	
	30 x 1.8	689 2Z	1.73C.S31.BAC	
Steel	20 x 1.5	689 2Z	1.73A.J20.BAC	1.72A.J20.EAN
	30 x 1.2	689 2Z	1.73A.J31.BAC	1.731.J31.EAN

Female threaded shaft version

Material	Ø mm	Ball bearing	Shaft
			Reference number Ø 8 mm (M5 x 12)
PVC	20 x 1.5	689 2Z	1.72B.S20.EAJ
	30 x 1.8	689 2Z	1.730.S31.EAJ
Steel	20 x 1.5	689 2Z	1.72B.J20.EAJ
	30 x 1.2	689 2Z	1.731.J31.EAJ

Example of a reference number: 1.72A.J20.EAN - 495

This reference number is for a conveyor roller Series 1700 light, steel, Ø tube 20 mm, Ø shaft 8 mm, spring-loaded shaft and reference length 495 mm. The reference length RL can be found in the table of dimensions for spring-loaded shafts: $RL = EL - 5$. The axial play of 0.5 mm per side has already been taken into account. The nominal clearance of your conveyor is 500 mm, also corresponding to the installation length EL, i. e. the reference length is: $500 - 5 = 495$ mm.

Standards

Ordering example



LIGHTWEIGHT CONVEYOR ROLLER SERIES 1700 LIGHT



Conveyor Rollers
Universal
Series 1700 light

Small diameter for smaller materials to be conveyed

Dimensions

RL	Reference length/Ordering length*
EL	Installation length
AGL	Total length of shaft
F	Length of the bearing assembly, including axial play

*The reference length/ordering length RL does not have any reference edges on the conveyor roller and can therefore not be shown.

Dimensions for spring-loaded shaft

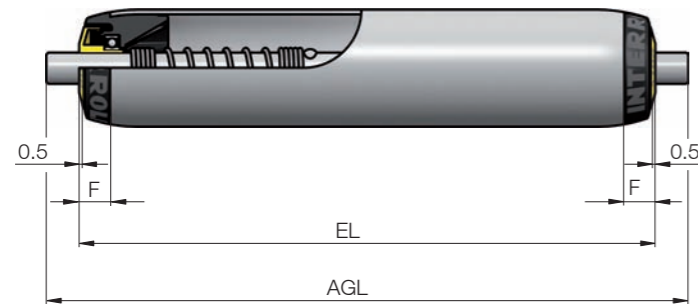

Ø Shaft mm	Ø Tube mm	RL mm	AGL mm	F mm
6	20	EL - 5	EL + 10	10.5
6	30	EL - 5	EL + 10	8.5
8	20	EL - 5	EL + 16	10.5
8	30	EL - 5	EL + 16	8.5

Dimensions for female threaded shaft M5 x 12

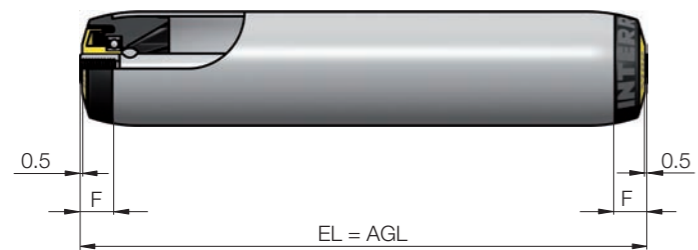

Ø Shaft mm	Ø Tube mm	RL mm	AGL mm	F mm
8	20	EL - 5	EL	10.5
8	30	EL - 5	EL	8.5

Options

We can offer you the following options in addition to our standard products:

- Antistatic version (not with PVC tube material)
- Tube sleeves for Ø 30 mm
 - Flexible PVC sleeve
 - Rubber coating



TAPERED FIXED DRIVE CONVEYOR ROLLER SERIES 3500KXO LIGHT



Conveyor Rollers
Fixed Drive Curve
Series 3500KXO light

The gravity roller with optimised light start-up

Product Description

- Customer benefits**
 - Compact dimensions
 - Small internal radius with 357.5 mm
 - Standard product for gravity and fixed drives
 - Integral drive head for round belt drives
 - Small pitches possible
 - Tube diameter Ø 23.4 mm to Ø 53.4 mm
- Applications**
 - In-house transport of smaller materials to be conveyed
 - Machine chains
 - Packaging industry
 - Automated assembly
- Properties**
 - Sealed precision ball bearing (689 2Z)
 - Rounded roller ends for simple lateral pushing
- Associated platform**
 - Platform 1700

Technical Data

General technical data

Max. load capacity, RL independent	150 N
Max. conveyor speed	0.8 m/s
Temperature range	-5 to +40 °C

Materials

Bearing housing	Polyamide
Seal	Polypropylene
Ball bearing	Steel 689 2Z
Tapered elements	Polypropylene

Product Selection

Female threaded shaft version

Material	Torque transmission	Reference length mm	Min. Ø mm	Max. Ø mm	Ball bearing	Shaft
						Reference number Ø 8 mm (M5 x 12)
Steel	Round belt head	150	23.4	31.4	689 2Z	3.52K.K21.EAK
		200	23.4	34.5	689 2Z	3.52K.K22.EAK
		250	23.4	37.7	689 2Z	3.52K.K23.EAK
		300	23.4	40.8	689 2Z	3.52K.K24.EAK
		350	23.4	43.9	689 2Z	3.52K.K25.EAK
		400	23.4	47.1	689 2Z	3.52K.K26.EAK
		450	23.4	50.2	689 2Z	3.52K.K27.EAK
		500	23.4	53.4	689 2Z	3.52K.K28.EAK

Example of a reference number: 3.52K.K28.EAK - 500

This reference number is for a conveyor roller Series 3500KXO light, steel, installation length 510 mm, Ø shaft 8 mm, female threaded shaft and reference length 500 mm. The reference length RL can be found on the dimensioned drawing: $RL = EL - 10$. The axial play of 0.5 mm per side has already been taken into account. The nominal clearance of your conveyor is 510 mm, also corresponding to the installation length EL, i. e. the reference length is: $510 - 10 = 500$ mm.

RL	Reference length/Ordering length
EL	Installation length
AGL	Total length of shaft

Dimensions for female threaded shaft M6 x 15

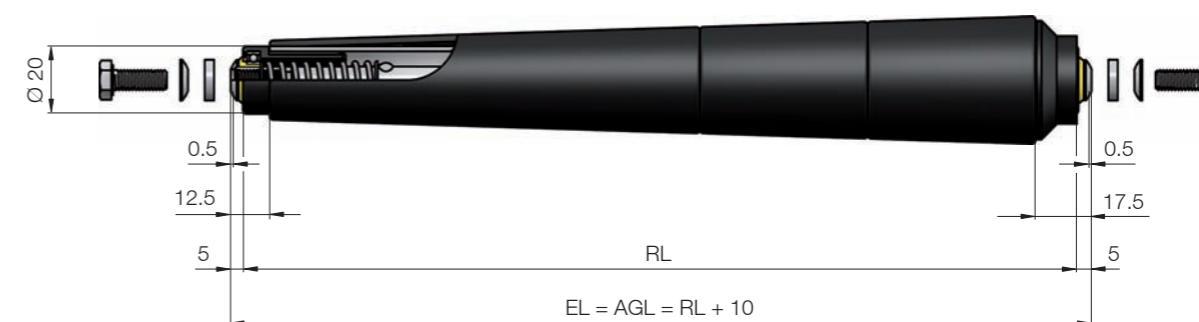

Options

We can offer you the following options in addition to our standard products:

- Inner tube made of corrosion-proof steel

Standards

Ordering example

Dimensions

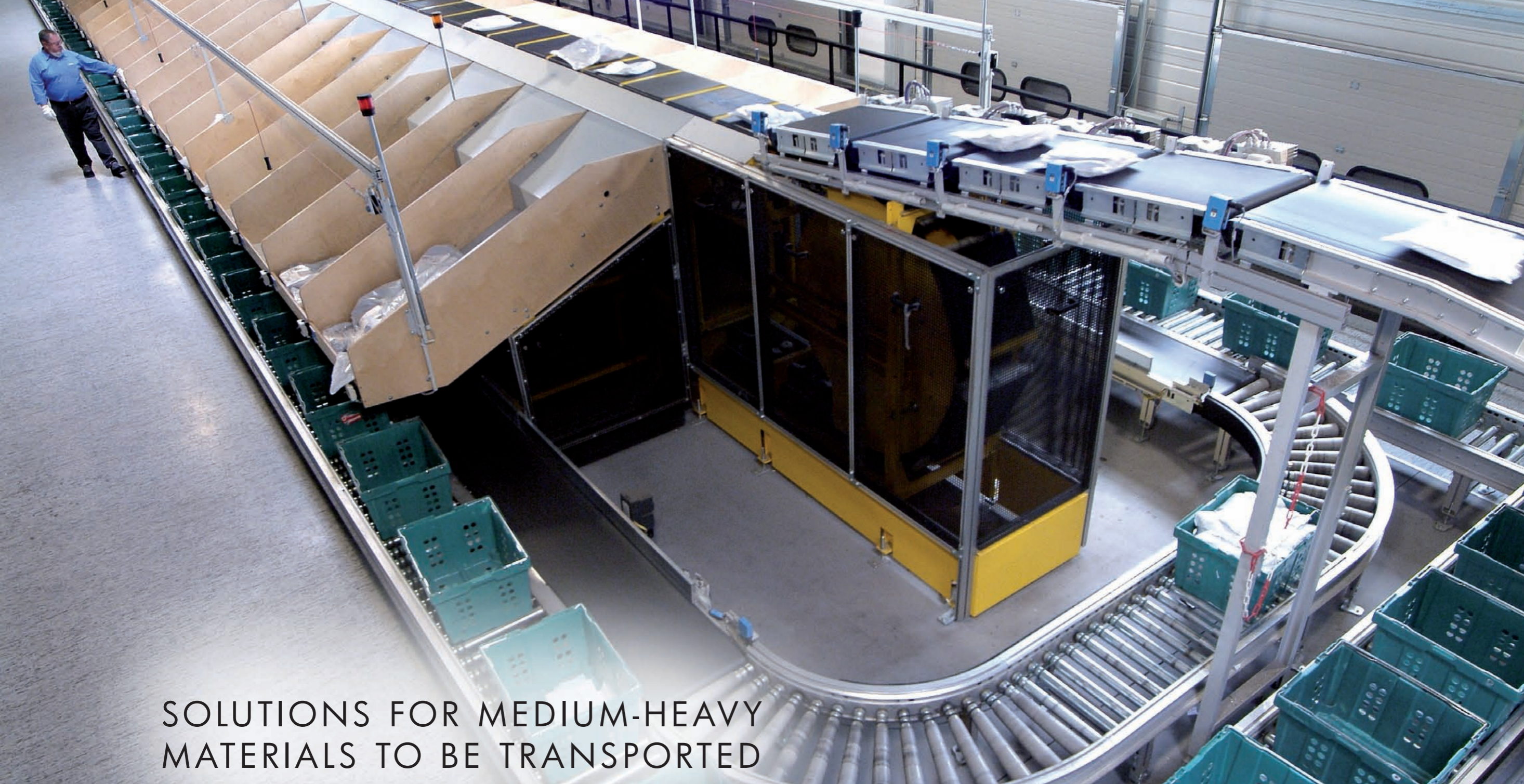

SOLUTIONS FOR MEDIUM-HEAVY MATERIALS TO BE TRANSPORTED

With this product range, you can set up roller conveyors for medium-heavy materials to be transported, for example for assembly lines, order picking systems or container conveyor technology with weights up to 500 kg and conveyor speeds of up to 2 m/s. The maximum load capacity of these products is 3,000 N per conveyor roller.

Products for medium-heavy materials to be transported

Conveyor Rollers	The basis of every roller conveyor	p 26
Magnetic Speed Controller 50	Controlled speed	p 82
RollerDrive	The roller with a drive	p 86
DriveControls	Controls for RollerDrive	p 104



OVERVIEW OF CONVEYOR ROLLERS

	Smooth-running Conveyor Roller Series 1100	Steel Conveyor Roller Series 1200	Slide Bearing Conveyor Roller Series 1500	Universal Conveyor Roller Series 1700	Tapered Universal Conveyor Roller Series 1700KXO	Fixed Drive Conveyor Roller Series 3500	Tapered Fixed Drive Conveyor Roller Series 3500KXO	Heavy-duty Conveyor Roller Series 3560	Friction Conveyor Roller Series 3800	Double Friction Conveyor Roller Series 3860	Double Friction Conveyor Roller Series 3870
Max. load capacity	350 N	1,200 N	120 N	3,000 N	500 N	2,000 N	500 N	3,000 N	500 N	1,300 N	500 N
Applications	Gravity	Cold/Warm	Moist area	Universal	Curve	Fixed drive	Fixed drive curve	Fixed drive	Friction drive	Double friction medium-heavy - heavy	Double friction medium-heavy
Drive concepts											
Gravity	✓	✓	✓	✓	✓						
Flat belt		✓	✓	✓	✓	✓					
Round belt				✓	✓	✓	✓				
Chain						✓	✓	✓	✓	✓	✓
Toothed belt						✓		✓			
PolyVee belt						✓	✓				
	see page 28	see page 32	see page 36	see page 38	see page 46	see page 50	see page 56	see page 62	see page 66	see page 74	see page 78



SMOOTH-RUNNING CONVEYOR ROLLER SERIES 1100



Conveyor Rollers
Gravity
Series 1100

The gravity roller with optimised light start-up

Product Description

- Customer benefits**
 - Cost-effective, corrosion-proof gravity roller
 - Use of stainless steel balls
 - Gentle lateral pushing of the materials to be conveyed
 - Rounded tube ends
 - Protects the bearing from coarse dirt and liquids
 - Integral water-repellent groove
 - Resistant to dirt
 - Smooth surfaces
- Applications**
 - In-house conveyor technology
 - Only gravity applications
- Properties**
 - Silent, precise smooth-running roller due to special steel ball bearings and tube made of polypropylene.
 - Form-fit join of the bearing housing with the tube above a diameter of 30 mm to avoid slipping of the bearing seat.
- Associated platform**
 - Platform 1100

Technical Data

General technical data	
Max. load capacity	350 N
Max. conveyor speed	0.3 m/s
Temperature range	-5 to +40 °C
Materials	
Bearing housing	Polypropylene
Seal	Polypropylene
Ball	Carbon steel or stainless steel 1.4301

The dynamic load and the surface load are the assumptions for the load capacity. The shaft version can be selected at will.

Tube material	Ø Tube mm	Ø Shaft mm	Max. load capacity in N with an installation length of mm													
			100	200	300	400	500	600	700	800	900	1,000	1,100	1,200		
PVC	16 x 1.0	5	33	7	3	2	-	-	-	-	-	-	-	-	-	-
	20 x 1.5	6	90	20	10	5	-	-	-	-	-	-	-	-	-	-
	30 x 1.8	8	120	100	40	20	15	10	-	-	-	-	-	-	-	-
	40 x 2.3	8	180	180	130	70	40	30	-	-	-	-	-	-	-	-
Steel	50 x 2.8	8/10	350	350	310	165	100	70	-	-	-	-	-	-	-	-
	16 x 1.0	5	50	50	50	50	-	-	-	-	-	-	-	-	-	-
	20 x 1.5	6	90	90	90	90	90	90	90	-	-	-	-	-	-	-
Aluminium	50 x 1.5	10/12	350	350	350	350	350	350	350	350	350	350	350	350	350	350
	20 x 1.5	6	90	90	90	90	85	60	43	-	-	-	-	-	-	-

Load capacity



SMOOTH-RUNNING CONVEYOR ROLLER SERIES 1100



Conveyor Rollers
Gravity
Series 1100

The gravity roller with optimised light start-up

Product Selection

Standards

Spring-loaded shaft version

Tube		Ball bearing	Shaft			
Material		Ø mm	Reference number			
			Ø 5 mm	Ø 6 mm	Ø 8 mm	Ø 10 mm
PVC	16 x 1.0	Stainless steel	1.1B5.S16.A50			
	20 x 1.5	Standard	1.1AZ.N21.D03			
	20 x 1.5	Stainless steel	1.1AZ.S20.D03			
	30 x 1.8	Standard	1.1DJ.S31.E03			
	30 x 1.8	Stainless steel	1.1DK.S31.G03			
	40 x 2.3	Standard	1.1DL.S40.E03			
	40 x 2.3	Stainless steel	1.1DM.S40.E03			
	50 x 2.8	Standard	1.1EJ.SAA.EAB		1.1EL.SAA.HAC	
	50 x 2.8	Stainless steel	1.1EK.SAA.GAB		1.1EM.SAA.KAC	
	Steel, stainless steel	16 x 1.0	Stainless steel	1.1B5.N10.A50		
20 x 1.5		Stainless steel	1.1AZ.N21.D03			
50 x 1.5		Stainless steel	1.1ED.NAA.KAC			
Steel, zinc-plated	50 x 1.5	Standard	1.1EC.JAA.HAC			
Aluminium, anodised	20 x 1.5	Stainless steel	1.1AZ.A2D.D03			

Female threaded shaft version

Tube		Ball bearing	Shaft
Material		Ø mm	Reference number
			Ø 12 mm (M8 x 15)
Steel, stainless steel	50 x 1.5	Stainless steel	1.1EF.NAA.MAS
Steel, zinc-plated	50 x 1.5	Standard	1.1EE.JAA.LAE

Ordering example

Example of a reference number: 1.1EJ.SAA.EAB - 490

This reference number is for a Conveyor Roller Series 1100, PVC, Ø tube 50 mm, standard ball bearing, Ø shaft 8 mm, spring-loaded shaft and reference length 490 mm. The reference length RL can be found in the table of dimensions for spring-loaded shafts: $RL = EL - 10$. The axial play of 0.5 mm per side has already been taken into account. The nominal clearance of your conveyor is 500 mm, which also corresponds to the installation length EL, i. e. the reference length is: $500 - 10 = 490$ mm.

Dimensions

RL	Reference length/Ordering length*
EL	Installation length
AGL	Total length of shaft
F	Length of the bearing assembly, including axial play

*The reference length/ordering length RL does not have any reference edges on the conveyor roller and can therefore not be shown.

Dimensions for spring-loaded shaft

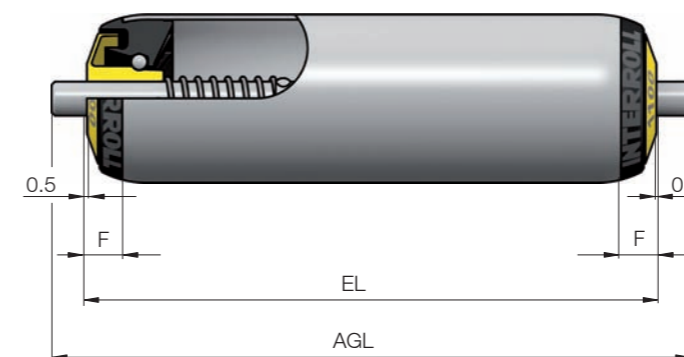

Ø Shaft mm	Ø Tube mm	RL mm	AGL mm	F mm
5	16	EL - 5	EL + 12	10.5
6	20	EL - 5	EL + 12	10.5
8	30	EL - 5	EL + 16	8.5
8	40	EL - 5	EL + 16	11
8	50	EL - 10	EL + 16	11
10	50	EL - 10	EL + 20	11

Dimensions for female threaded shaft M8 x 15

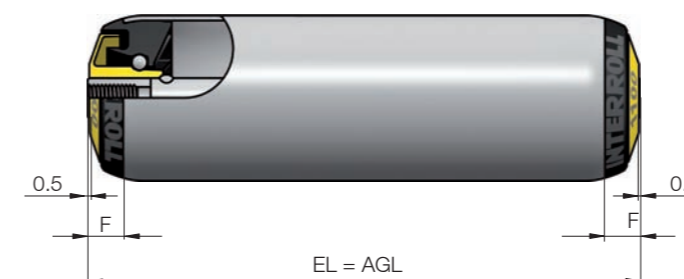

Ø Shaft mm	Ø Tube mm	RL mm	AGL mm	F mm
12	50	EL - 10	EL	11

Options

We can offer you the following options in addition to our standard products:

- Antistatic version
- Special surface finish for tubes
 - Hardened
 - Brushed stainless steel tubes
- Tube sleeves above Ø 30 mm
 - Flexible PVC sleeve
 - PU sleeve for Ø 50 mm
 - Rubber coating



STEEL CONVEYOR ROLLER SERIES 1200



Conveyor Rollers
Cold/Warm
Series 1200

Complete steel conveyor roller for extreme temperatures

Product Description

- Customer benefits**
 - Durable, tough, complete steel conveyor roller
 - Pressed and zinc-plated bearing seats with hardened running groove
 - Gentle lateral pushing of the materials to be conveyed
 - Rounded tube ends
- Applications**
 - Extended temperature ranges of -28 °C to +80 °C
 - Driven and non-driven container conveyor technology
- Properties**
 - Antistatic version
 - Zinc-plated steel bearing housing
 - Shape of ball bearing optimised for conveyor rollers, permits greater bearing deflection
- Associated platform**
 - Platform 1200

Technical Data

General technical data

Max. load capacity	1,200 N
Max. conveyor speed	0.8 m/s
Temperature range	-28 to +80 °C

Materials

Bearing housing	Steel, zinc-plated
Ball bearing	Steel, hardened running grooves

The dynamic load and the surface load are the assumptions for the load capacity.

Load capacity

Spring-loaded shaft version

Tube material	Ball bearing	Ø Tube mm	Ø Shaft mm	Max. load capacity in N with an installation length of mm																
				100	200	300	400	500	600	700	800	900	1000	1200	1400	1600				
Steel, zinc-plated	Metal ball bearing, hardened	30 x 1.2 50 x 1.5	8 10	120	120	120	120	120	120	120	120	120	120	120	920	825	750	640	560	440

Female threaded shaft version

Tube material	Ball bearing	Ø Tube mm	Ø Shaft mm	Max. load capacity in N with an installation length of mm																
				100	200	300	400	500	600	700	800	900	1000	1200	1400	1600				
Steel, zinc-plated	Metal ball bearing, hardened	50 x 1.5	12	1200	1200	1200	1200	1200	1200	1200	1200	1200	1200	1100	780	570	440			



STEEL CONVEYOR ROLLER SERIES 1200



Conveyor Rollers
Cold/Warm
Series 1200

Complete steel conveyor roller for extreme temperatures

Product Selection

Standards Spring-loaded shaft version

Tube		Ball bearing	Shaft	
Material	Ø mm		Ø 8 mm	Ø 10 mm
Steel, zinc-plated	30 x 1.2	Metal ball bearing, hardened	1.2A2.J31.E9F	
	50 x 1.5	Metal ball bearing, hardened		1.2MG.JAA.H97

Female threaded shaft version

Tube		Ball bearing	Shaft
Material	Ø mm		Reference number
Steel, zinc-plated	50 x 1.5	Metal ball bearing, hardened	Ø 12 mm (M8 x 15) 1.2MH.JAA.L04

Ordering example

Example of a reference number: 1.2A2.J31.E9F - 494

This reference number is for a conveyor roller Series 1200, Ø tube 30 mm, Ø shaft 8 mm, spring-loaded shaft and reference length 494 mm. The reference length RL can be found in the table of dimensions for spring-loaded shafts: $RL = EL - 6$. The axial play of 0.5 mm per side has already been taken into account. The nominal clearance of your conveyor is 500 mm, which also corresponds to the installation length EL, i. e. the reference length is: $500 - 6 = 494$ mm.

Dimensions

RL	Reference length/Ordering length
EL	Installation length
AGL	Total length of shaft
F	Length of the bearing assembly, including axial play

Dimensions for spring-loaded shaft

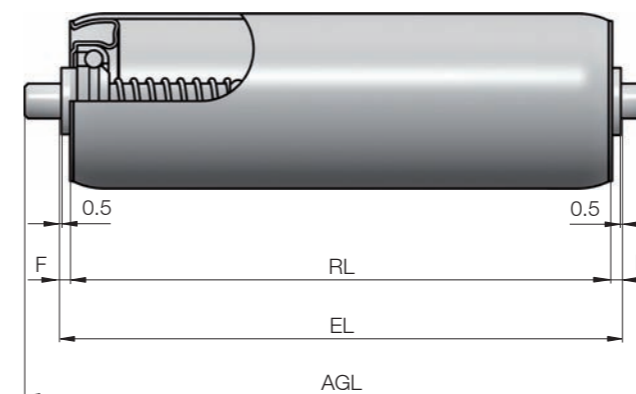

Ø Shaft mm	Ø Tube mm	RL mm	AGL mm	F mm
8	30	EL - 6	EL + 16	4
10	50	EL - 6	EL + 20	4

Dimensions for female threaded shaft M8 x 15

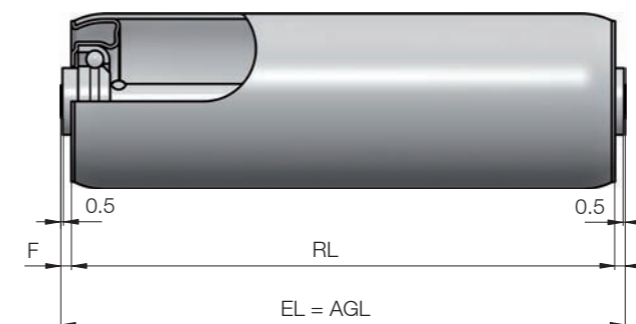

Ø Shaft mm	Ø Tube mm	RL mm	AGL mm	F mm
12	50	EL - 6	EL	4

Options

We can offer you the following options in addition to our standard products:

- Flanges
- Special surface finish for tubes
 - Hardened



SLIDE BEARING CONVEYOR ROLLER SERIES 1500



Conveyor Rollers
Moist area
Series 1500

Sealed, ideal for moist areas and to comply with hygiene requirements

Product Description

- Customer benefits**
- Slide bearing conveyor roller; suitable for cleaning with conventional detergents.
 - External slide bearing and pressed bearing housings, which prevent the penetration of foreign bodies into the inside of the roller
 - Corrosion-proof conveyor roller
 - Stainless steel shaft pin, PVC / stainless steel tubes, polypropylene bearing housing
 - Durable, smooth-running slide bearing conveyor roller
 - External, wear-resistant slide bearing made of POM + PTFE
- Applications**
- Food sector to comply with hygiene regulations
 - Moist area
 - Driven and non-driven container conveyor technology
 - Suitable for materials to be transported with a weight of 20 kg
- Properties**
- Slide bearing clip to snap into a profile with max. 2.5 mm wall thickness and hexagonal holes 11 mm (+0.3 / +0.8 mm)
 - Stainless steel shaft pins
 - Simple to remove slide bearing clip to insert and remove the conveyor rollers
- Associated platform**
- Platform 1500

Technical Data

General technical data

Max. load capacity	120 N
Max. conveyor speed	0.8 m/s
Temperature range	-10 to +40 °C

Materials

Bearing housing	Polypropylene
Shaft pin	Steel, stainless steel
Slide bearing	Polyoxymethylene

Load capacity The load capacity is affected by the length of the roller and by the dependent parameters of the weight of the material to be conveyed and the conveying speed.

The load capacity depends on the speed

Ø Tube mm	Speed m/s	Max. load capacity N
30	0.25	50
	0.80	40
50	0.25	120
	0.80	85

The load capacity depends on the reference length

Tube material	Ø Tube mm	Max. load capacity in N with an installation length of mm							
		100	200	300	400	500	600	700	800
PVC	30 x 1.8	50	50	35	20	12	-	-	-
	50 x 2.8	120	120	120	120	95	65	48	35
Steel	30 x 1.2	50	50	50	50	50	50	50	50
	50 x 1.5	120	120	120	120	120	120	120	120

Product Selection

Shaft pin shaft version

Tube Material	Ø mm	Bearing design	Shaft pin Ø 6 mm
PVC	30 x 1.8	Slide bearing	1.5AB.S3B.00C
	50 x 2.8	Slide bearing	1.5AF.SAA.00C
Steel, stainless steel	30 x 1.2	Slide bearing	1.5AA.N31.00C
	50 x 1.5	Slide bearing	1.5AE.NAA.00C
Steel, zinc-plated	30 x 1.2	Slide bearing	1.5AA.J31.00C
	50 x 1.5	Slide bearing	1.5AE.JAA.00C

Standards

Example of a reference number: 1.5AF.SAA.00C - 490

This reference number is for a Conveyor Roller Series 1500, PVC, Ø tube 50 mm, Ø shaft pin 6 mm and reference length 490 mm. The reference length RL can be found on the dimensioned drawing: $RL = EL - 10$. The axial play of 0.5 mm per side has already been taken into account. The nominal clearance of your conveyor is 500 mm, which also corresponds to the installation length EL, i. e. the reference length is: $500 - 10 = 490$ mm.

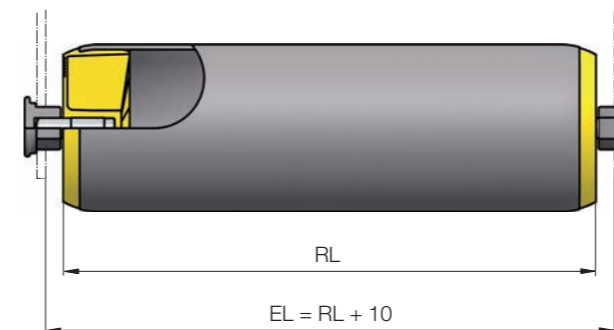

RL	Reference length/Ordering length
EL	Installation length

Ordering example

Dimensions

Options

We can offer you the following options in addition to our standard products:

- Tube sleeves
 - Flexible PVC sleeve
 - PU sleeve for Ø 50 mm
 - Rubber coating
- Special surface finish for tubes
 - Brushed stainless steel tubes



UNIVERSAL CONVEYOR ROLLER SERIES 1700



Conveyor Rollers
Universal
Series 1700

Flexible use - the silent conveyor roller for heavy-duty loads

Product Description

- Customer benefits**
 - Tried and tested a million times over
 - Universal Conveyor Roller with an extensive range of applications
 - Silent conveyor roller
 - Precision ball bearing, technopolymer bearing housing and seal
 - Protects the ball bearing from coarse dirt and water
 - Integral water-repellent groove
 - Axial loads are possible
 - Axial forces diverted by ball bearing
 - Gentle lateral pushing of the materials to be conveyed
 - Rounded tube ends
- Applications**
 - In-house conveyor technology
 - Driven conveyors for packaged goods
 - Transport of tyres and rims
- Properties**
 - Sealed precision ball bearings (6002 2RZ, 6003 2RZ, 689 2Z)
 - Form-fit axial fixing of bearing housing, ball bearing and seal
- Associated platform**
 - Platform 1700

Technical Data

General technical data

Max. load capacity	3,000 N
Max. conveyor speed	2.0 m/s
Temperature range	-5 to +40 °C

Materials

Bearing housing	Polyamide
Seal	Polypropylene
Ball bearing	6003 2RZ / Steel 6002 2RZ / Steel 689 2Z

The load capacity depends on the shaft version, the tube diameter and the length of the roller.

Tube material	Shaft version	Ball bearing	Ø Tube mm	Ø Shaft mm	Max. load capacity in N with an installation length of mm									
					200	300	400	600	800	1000	1300	1600		
PVC	Spring-loaded shaft	6002 2RZ	50 x 2.8	8-10	660	280	150	65	36	-	-	-	-	
Steel	Spring-loaded shaft	689 2Z	30 x 1.2	8	150	150	150	150	-	-	-	-	-	
			40 x 1.5	10-12	800	800	800	800	730	490	330	-		
		12		1800	1140	840	560	420	340	260	220			
		11 hex		2000	2000	1640	1020	780	640	520	440			
		60 x 1.5	10	1630	1130	830	540	400	320	250	200			
			12	2000	2000	1740	1160	870	700	580	460			
			11 hex	2000	2000	1500	1000	740	600	475	390			
		Female thread	6002 2RZ	40 x 1.5	12	800	800	800	800	800	560	330	-	
					14	2000	2000	2000	2000	1770	1120	660	440	
					17	3000	3000	3000	3000	1770	1120	660	440	
				60 x 1.5	12	2000	2000	2000	2000	2000	2000	2000	1160	760
					14	2000	2000	2000	2000	2000	2000	2000	1160	760
				6003 2RZ	60 x 3.0	17	3000	3000	3000	3000	3000	3000	3000	2140
Tapered shaft-shuttle	6002 2RZ	50 x 1.5	11-12 hex	350	350	350	350	350	350	-	-			

Load capacity



UNIVERSAL CONVEYOR ROLLER SERIES 1700

Flexible use - the silent conveyor roller for heavy-duty loads



Conveyor Rollers
Universal
Series 1700

Product Selection

Standards

Spring-loaded shaft version

Tube				Ball bearing	Shaft			
Material	Ø mm	Torque transmission	Sleeve		Reference number			
					Ø 8 mm	Ø 10 mm	11 mm hex	Ø 12 mm
PVC	50 x 2.8	Without grooves	–	6002 2RZ	1.7XJ.SAA.GAB	1.7XK.SAA.KAC		
		Without grooves	–	6002 2RZ	1.7X9.SAA.EAB	1.7X0.SAA.HAC		
Steel, stainless steel	50 x 1.5	Without grooves	–	6002 2RZ		1.7XQ.NAA.KAC		1.7XR.NAA.MB0
Steel, zinc-plated	30 x 1.2	Without grooves	–	6002 2RZ	1.731.J31.EAN			
		Without grooves	–	689 2Z	1.731.J31.EAN			
	40 x 1.5	Without grooves	PVC, 5 mm	6002 2RZ	1.7W1.JF5.EAB	1.7W2.JF5.HAC	1.7W5.JF5.VAB	1.7W3.JF5.LAC
		Without grooves	–	6002 2RZ		1.7W2.JF4.HAC	1.7W5.JF4.VAB	1.7W3.JF4.LAC
	50 x 1.5	1 groove	–	6002 2RZ		1.7X2.JAD.HAC	1.7X5.JAD.VAB	1.7X3.JAD.LAC
		2 grooves	PVC, 2 mm	6002 2RZ		1.7X2.JCG.HAC	1.7X5.JCG.VAB	1.7X3.JCG.LAC
		2 grooves	–	6002 2RZ		1.7X2.JAE.HAC	1.7X5.JAE.VAB	1.7X3.JAE.LAC
		Without grooves	PVC, 2 mm	6002 2RZ		1.7X2.J72.HAC	1.7X5.J72.VAB	1.7X3.J72.LAC
	60 x 1.5	Without grooves	–	6002 2RZ		1.7X2.JAA.HAC	1.7X5.JAA.VAB	1.7X3.JAA.LAC
	60 x 1.5	Without grooves	–	6002 2RZ		1.7Y2.JAB.HAC	1.7Y5.JAB.VAB	1.7Y3.JAB.LAC

Female threaded shaft version

Tube				Ball bearing	Shaft		
Material	Ø mm	Torque transmission	Sleeve		Reference number		
					Ø 12 mm (M8 x 15)	Ø 14 mm (M8 x 15)	Ø 17 mm (M12 x 20)
Steel, zinc-plated	40 x 1.5	Without grooves	–	6002 2RZ	1.7W3.JF4.LAE	1.7W4.JF4.NAE	
		Without grooves	PVC, 5 mm	6002 2RZ	1.7W3.JF5.LAE	1.7W4.JF5.NAE	
	50 x 1.5	Without grooves	–	6002 2RZ	1.7X3.JAA.LAE	1.7X4.JAA.NAE	
		Without grooves	PVC, 2 mm	6002 2RZ	1.7X3.J72.LAE	1.7X4.J72.NAE	
		2 grooves	PVC, 2 mm	6002 2RZ	1.7X3.JCG.LAE	1.7X4.JCG.NAE	
		2 grooves	–	6002 2RZ	1.7X3.JAE.LAE	1.7X4.JAE.NAE	
	60 x 1.5	Without grooves	–	6002 2RZ	1.7X3.JAD.LAE	1.7X4.JAD.NAE	
	60 x 1.5	Without grooves	–	6002 2RZ	1.7Y3.JAB.LAE	1.7Y4.JAB.NAE	
	50 x 1.5	Without grooves	–	6003 2RZ			1.75K.JAA.RAA
	60 x 3.0	Without grooves	–	6003 2RZ			1.75L.J63.RAA

Tapered shaft-shuttle shaft version

Tube				Ball bearing	Shaft	
Material	Ø mm	Torque transmission	Sleeve		Reference number	
					8 mm hex, shuttle 11 mm hex	
Steel, zinc-plated	50 x 1.5	Without grooves	–	6002 2RZ	1.7X7.JX5.V8T	
		2 grooves	PVC, 2 mm	6002 2RZ	1.7X7.JCG.V8T	
		2 grooves	–	6002 2RZ	1.7X7.JAE.V8T	
		1 groove	–	6002 2RZ	1.7X7.JAD.V8T	

On request, we can offer you further options in addition to our standard products (cf. p 45).

Please state the reference length RL and optionally the dimensions for the grooves and tube sleeve on in addition to the reference number.

Example of a reference number: 1.7X5.JAA.VAB - 490

This reference number is for a conveyor roller Series 1700, Ø tube 50 mm, zinc-plated steel, without grooves shaft version 11 mm hex spring-loaded shaft and reference length 490 mm. The reference length RL can be found in the table of dimensions for spring-loaded shafts: $RL = EL - 10$. The axial play of 0.5 mm per side has already been taken into account. The nominal clearance of your conveyor is 500 mm, which also corresponds to the installation length EL, i. e. the reference length is: $500 - 10 = 490$ mm.

Ordering information

Ordering example



UNIVERSAL CONVEYOR ROLLER SERIES 1700



Conveyor Rollers
Universal
Series 1700

Flexible use - the silent conveyor roller for heavy-duty loads

Dimensions

RL	Reference length/Ordering length*
EL	Installation length
AGL	Total length of shaft
F	Length of the bearing assembly, including axial play

*The reference length/ordering length RL does not have any reference edges on the conveyor roller and can therefore not be shown.

Dimensions for spring-loaded shaft

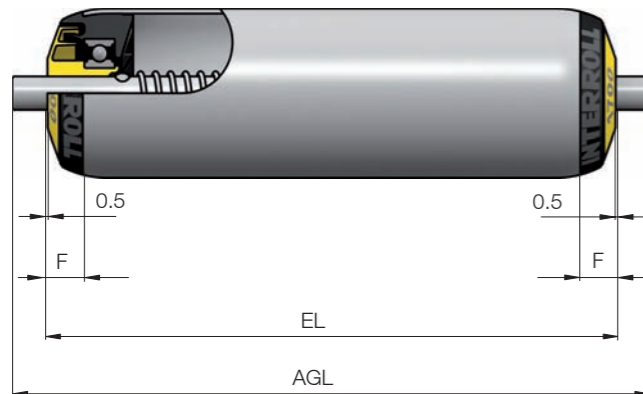

Ø Shaft mm	Ø Tube mm	RL mm	AGL mm	F mm
8	30 / 40 / 50	EL - 10	EL + 16	8.5 / 11 / 11
10	40 / 50 / 60	EL - 10	EL + 20	11
12	50 / 60	EL - 10	EL + 24	11
11 hex	50 / 60	EL - 10	EL + 22	11

Dimensions for female threaded shaft

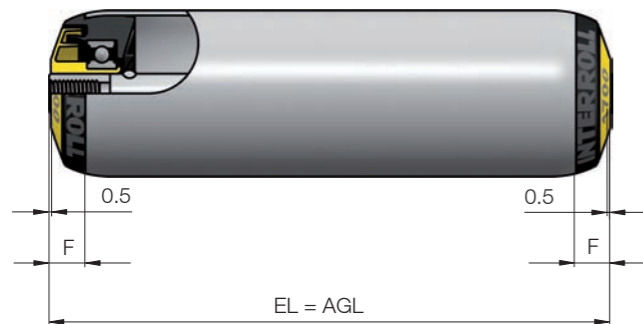

Ø Shaft mm	Thread mm	Ø Tube mm	RL mm	AGL mm	F mm
12	M8 x 15	40 / 50 / 60	EL - 10	EL	11
14	M8 x 15	50 / 60 / 80	EL - 10	EL	11
17	M12 x 20	50 / 60	EL - 10	EL	11

Dimensions for tapered shaft-shuttle

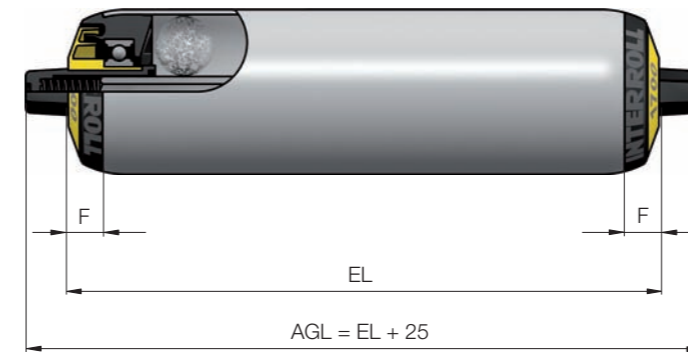

Ø Shaft mm	Shuttle mm	Ø Tube mm	RL mm	AGL mm	F mm
8 hex	11-12 hex	50	EL - 10	EL + 25	11

Ordering Dimensions for Grooves and Tube Sleeves

Version with grooves

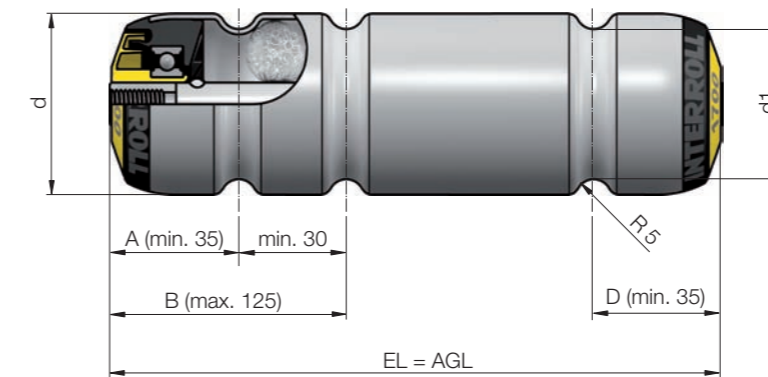

Grooves

d mm	d1 mm
40	28.3
50	38.4
60	48.4
80	68.4



UNIVERSAL CONVEYOR ROLLER SERIES 1700



Conveyor Rollers
Universal
Series 1700

Flexible use - the silent conveyor roller for heavy-duty loads

- Tube sleeves**
- For the transport of sensitive material to be conveyed
 - To reduce the noise level
 - To improve the coefficient of friction
 - To reduce speeds

Please note that The minimum sleeve width is 50 mm, the minimum installation length (EL) is 100 mm.

When ordering a conveyor roller with tube sleeve, please state the relevant dimensions A - D.

With PVC sleeve

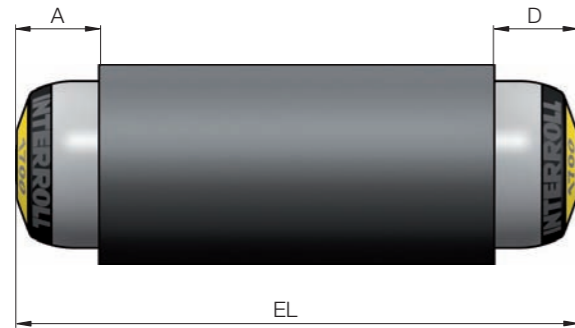

With grooves and PVC sleeve

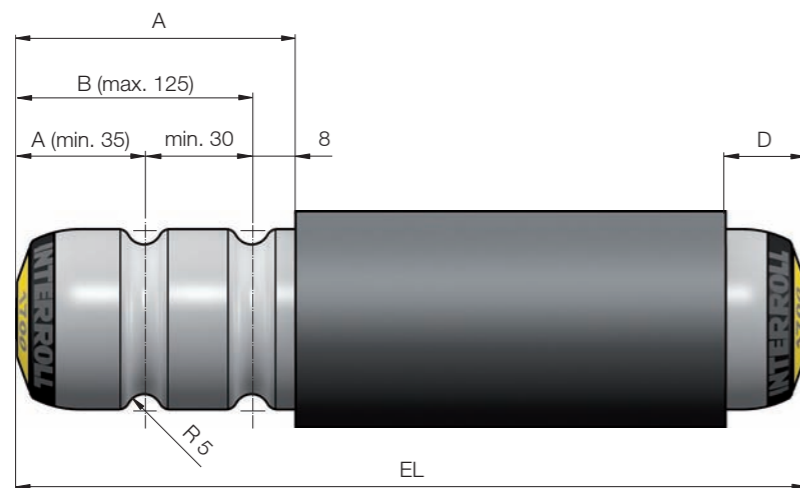

With PVC sleeve, cut

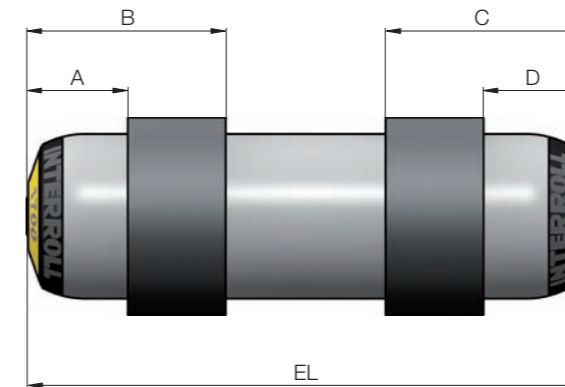

Options

We can offer you the following options in addition to our standard products:

- Antistatic version (standard with conveyor rollers with grooves)
- Other tube materials
 - Aluminium
- Special surface finish for tubes
 - Hardened
 - Brushed stainless steel tubes
- Tube sleeves
 - Flexible PVC sleeve
 - PU sleeve for Ø50 mm
 - Rubber coating
- Other shaft versions
 - Shaftless version
 - Flatted shaft
 - Male threaded shaft
- Lubrication options for ball bearing
 - Oiled
 - Lubricated (standard)

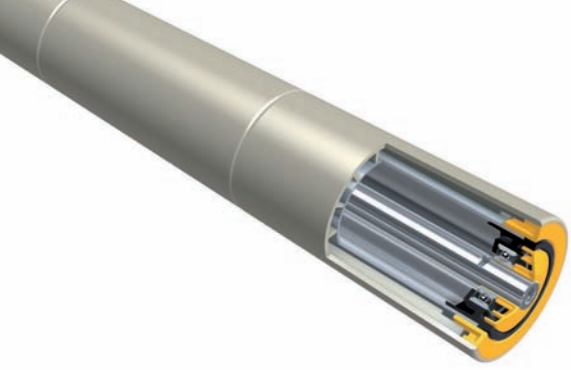

TAPERED UNIVERSAL CONVEYOR ROLLER SERIES 1700KXO



Conveyor Rollers
Curve
Series 1700KXO

Standard solution for gravity or driven curves

Product Description

- Customer benefits**
 - Standard product tried and tested a million times over
 - Based on the Universal Conveyor Roller Series 1700
 - Good starting properties
 - Low net weight due to tapered polypropylene elements
 - Abrasion-proof, sound-reducing, impact-resistant and weather-resistant
 - Tapered technopolymer elements
- Applications**
 - In-house conveying
 - Gravity or belt drives
 - Curves for crates and containers
- Properties**
 - Sealed precision ball bearing (6002 2RZ)
 - End cap for tapered elements
- Associated platform**
 - Platform 1700

Technical Data

General technical data

Max. load capacity, RL independent	500 N
Max. conveyor speed	2.0 m/s
Temperature range	-5 to +40 °C

Materials

Bearing housing	Polyamide
Seal	Polypropylene
Ball bearing	Steel 6002 2RZ
Tapered elements	Polypropylene

Product Selection

Female threaded shaft version

Material	Torque transmission	Reference length mm	Min. Ø mm	Max. Ø mm	Tube	Ball bearing	Shaft
							Reference number Ø 14 mm (M8 x 15)
Steel, zinc-plated	Without grooves	250	55.6	71.2	6002 2RZ	1.7H4.HE2.NAE	
		300	52.5	71.2	6002 2RZ	1.7H4.HF3.NAE	
		350	55.6	77.6	6002 2RZ	1.7H4.HE3.NAE	
		400	52.5	77.6	6002 2RZ	1.7H4.HF4.NAE	
		450	55.6	84.0	6002 2RZ	1.7H4.HE4.NAE	
		500	52.5	84.0	6002 2RZ	1.7H4.HF5.NAE	
		550	55.6	90.4	6002 2RZ	1.7H4.HE5.NAE	
		600	52.5	90.4	6002 2RZ	1.7H4.HF6.NAE	
		650	55.6	96.8	6002 2RZ	1.7H4.HE6.NAE	
	700	52.5	96.8	6002 2RZ	1.7H4.HF7.NAE		
	750	55.6	103.2	6002 2RZ	1.7H4.HE7.NAE		
	800	52.5	103.2	6002 2RZ	1.7H4.HF8.NAE		
	850	55.6	109.6	6002 2RZ	1.7H4.HE8.NAE		
	900	52.6	109.6	6002 2RZ	1.7H4.HF9.NAE		
	2 grooves	250	55.6	64.8	6002 2RZ	1.7H4.HG2.NAE	
		300	52.5	64.8	6002 2RZ	1.7H4.HH3.NAE	
		350	55.6	71.2	6002 2RZ	1.7H4.HG3.NAE	
		400	52.5	71.2	6002 2RZ	1.7H4.HH4.NAE	
450		55.6	77.6	6002 2RZ	1.7H4.HG4.NAE		
500		52.5	77.6	6002 2RZ	1.7H4.HH5.NAE		
550		55.6	84.0	6002 2RZ	1.7H4.HG5.NAE		
600		52.5	84.0	6002 2RZ	1.7H4.HH6.NAE		
650		55.6	90.4	6002 2RZ	1.7H4.HG6.NAE		
700	52.5	90.4	6002 2RZ	1.7H4.HH7.NAE			
750	55.6	96.8	6002 2RZ	1.7H4.HG7.NAE			
800	52.5	96.8	6002 2RZ	1.7H4.HH8.NAE			
850	55.6	103.2	6002 2RZ	1.7H4.HG8.NAE			
900	52.5	103.2	6002 2RZ	1.7H4.HH9.NAE			

Example of a reference number: 1.7H4.HF5.NAE - 490

This reference number is for a Conveyor Roller Series 1700KXO, steel, zinc-plated, without grooves, reference length 500 mm, Ø shaft 14 mm, female threaded shaft and reference length 490 mm. The reference length RL can be found on the dimensioned drawing: $RL = EL - 10$. The axial play of 0.5 mm per side has already been taken into account. The nominal clearance of your conveyor is 500 mm, which also corresponds to the installation length EL, i. e. the reference length is: $500 - 10 = 490$ mm.

Ordering example

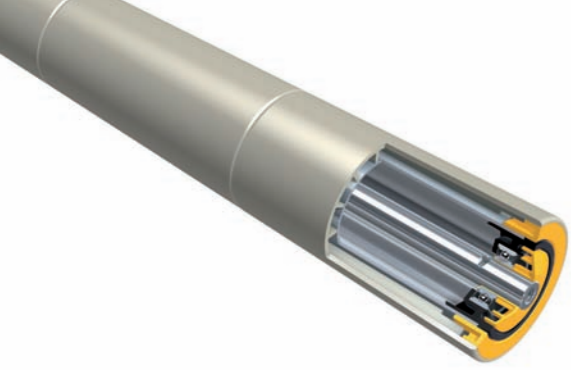

TAPERED UNIVERSAL CONVEYOR ROLLER SERIES 1700KXO



Conveyor Rollers
Curve
Series 1700KXO

Standard solution for gravity or driven curves

Dimensions

RL	Reference length/Ordering length*
EL	Installation length
AGL	Total length of shaft

*The reference length/ordering length RL does not have any reference edges on the conveyor roller and can therefore not be shown.

Dimensions for tapered elements on zinc-plated steel tube

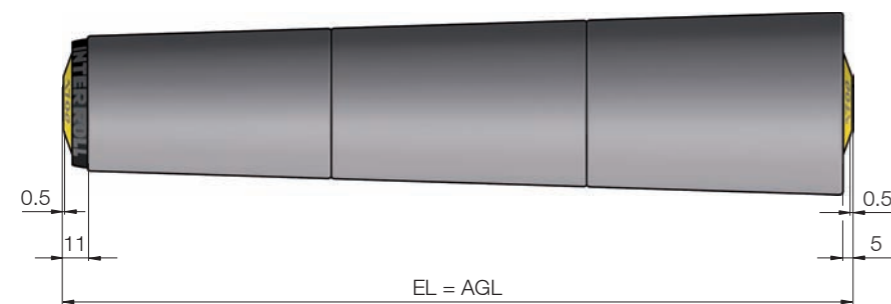

Dimensions for tapered elements on zinc-plated steel tube with two grooves

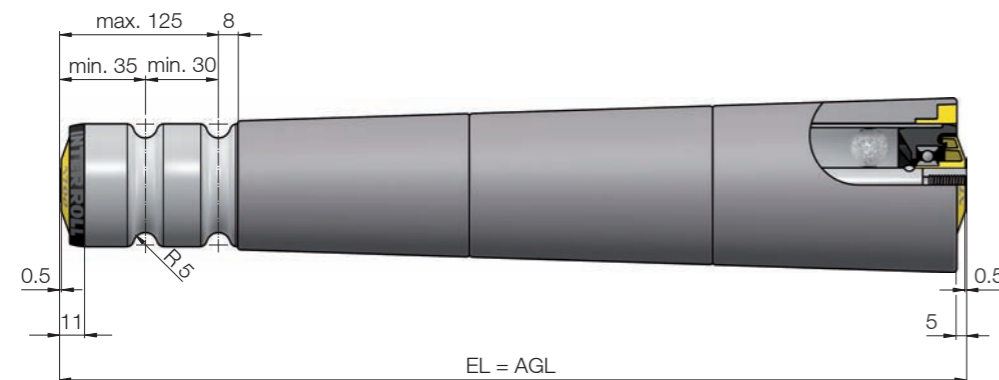

Options

We can offer you the following options in addition to our standard products:

- Internal curve radius 650 mm
- Projection of bearing tube at the internal or external radius

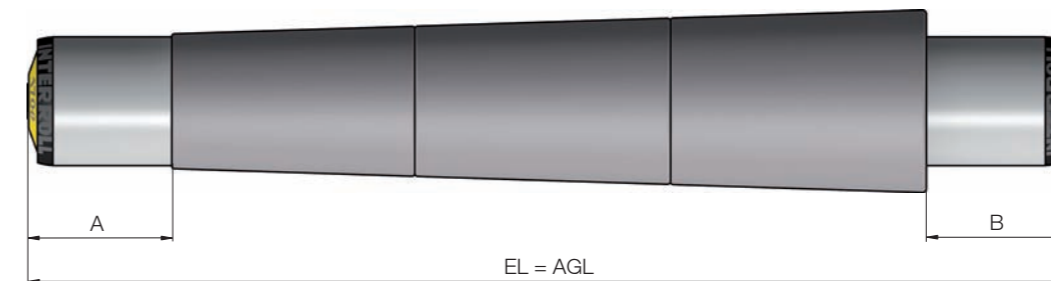

The following dimensions are needed when ordering a tube projection at one or both ends: Dimension A on the internal radius of the curve and Dimension B on the external radius of the curve. If you require a tube projection at one side only, please enter a 0 for the other dimension.

Please contact your Interroll customer consultant for other tube versions:

- Both sides without grooves
- Grooves on internal radius of curve
- Grooves on external radius of curve

Ordering information



FIXED DRIVE CONVEYOR ROLLER SERIES 3500



Conveyor Rollers
Fixed drive
Series 3500

Low-noise fixed drive, different drive types

Product Description

- Customer benefits**
 - Exceptionally low-noise operation
 - Polyamide drive heads (alternatively sprockets made of steel)
 - Replaceable chain heads and toothed belt heads for fixed and friction drives
 - Fixed bearing housing for attachable drive heads
 - Comprehensive drive versions
 - Round, PolyVee, toothed and flat belts; chain drive 1/2" Z9, Z11, Z14
- Applications**
 - Transport of medium-heavy materials to be conveyed
 - Drums, tyres, boxes
- Properties**
 - Sealed precision ball bearing (6002 2RZ)
 - Series 3500 based on Series 1700
- Associated platform**
 - Platform 1700
- New development Round belt head with 2 grooves**
 - The drive head is pressed into the tube by a press fit
 - No tube deformation by grooves
 - Spatial separation of drive and conveyor areas
 - Standard round belt
- New development PolyVee head with 9 grooves**
 - The drive head is pressed into the tube by a press fit
 - Twice the torque transmission is possible when using flexible PolyVee belts with only 2 ribs compared with a comparable round belt
 - Spatial separation of drive and conveyor areas

Technical Data

General technical data

Max. load capacity	2,000 N
Max. conveyor speed	2 m/s (with chain drive 0.5 m/s)
Temperature range	-5 to +40 °C

Materials

Bearing housing	Polyamide
Drive head	Polyamide / Steel
Seal	Polypropylene
Ball bearing	Steel 6002 2RZ

The load capacity depends on the length of the roller, the tube diameter and the torque transmission.

Load capacity

Female threaded shaft version

Tube material	Ball bearing	Torque transmission	Ø Tube mm	Ø Shaft mm	Max. load capacity in N with an installation length of mm							
					200	400	600	800	1000	1200	1400	
PVC	6002 2RZ	Polymer sprocket Z = 11	50 x 2.8	14	300	300	110	40	-	-	-	
		1 & 2 polymer sprockets Z = 14	50 x 2.8	14	350	265	90	50	-	-	-	
		Toothed belt head Z = 18										
Steel, zinc-plated	6002 2RZ	Polymer sprocket Z = 11	50 x 1.5	14	300	300	300	300	300	290	250	
		1 & 2 polymer sprockets Z = 14	50 x 1.5	14	1500	1500	1450	1410	1370	910	650	
		Toothed belt head Z = 18	50 x 1.5									
		Round belt head & PolyVee Heads	50 x 1.5	14	350	350	350	350	350	350	350	
		1 & 2 polymer sprockets Z = 14	60 x 1.5	14	1500	1500	1450	1410	1390	1370	1150	
		Toothed belt head Z = 18	60 x 1.5									
		1 & 2 steel sprockets Z = 14	50 x 1.5	14	2000	2000	2000	1830	1150	790	580	
			60 x 1.5									



FIXED DRIVE CONVEYOR ROLLER SERIES 3500



Conveyor Rollers
Fixed drive
Series 3500

Low-noise fixed drive, different drive types

Product Selection

Standards Tapered shaft-shuttle shaft version

Material	Ø mm	Torque transmission	Ball bearing	Shaft Reference number Tapered shaft-shuttle on 8 mm hex
Steel, zinc-plated	50 x 1.5	Round belt head with 2 grooves	6002 2RZ	3.5R6.JAA.V8U

Female threaded shaft version

Material	Ø mm	Torque transmission	Ball bearing	Shaft Reference number Ø 14 mm (M8 x 15)	
PVC	50 x 2.8	Polymer sprocket 1/2", Z = 14	6002 2RZ	3.5M3.SAA.N90	
		Polymer sprocket 1/2", Z = 11	6002 2RZ	3.5M1.SAA.N90	
		2 polymer sprockets 1/2", Z = 14	6002 2RZ	3.5M5.SAA.N91	
Steel, zinc-plated	50 x 1.5	Toothed belt head	6002 2RZ	3.5B3.JAA.N90	
		Steel sprocket 1/2", Z = 14	6002 2RZ	3.504.JA4.N90	
		Round belt head	6002 2RZ	3.5R4.JAA.N7X	
		Polymer sprocket 1/2", Z = 14	6002 2RZ	3.5RD.JAA.N90	
		Polymer sprocket 1/2", Z = 11	6002 2RZ	3.5H4.JAA.N90	
		PolyVee head	6002 2RZ	3.5PA.JAA.N7X	
		2 steel sprockets 1/2", Z = 14	6002 2RZ	3.504.JA3.N91	
		2 polymer sprockets 1/2", Z = 14	6002 2RZ	3.5HJ.JAA.N91	
		60 x 1.5	Toothed belt head	6002 2RZ	3.5NB.JAB.N90
			Steel sprocket 1/2", Z = 14	6002 2RZ	3.50T.JC1.N90
			Polymer sprocket 1/2", Z = 14	6002 2RZ	3.5N3.JAB.N90
			2 steel sprockets 1/2", Z = 14	6002 2RZ	3.50T.JC2.N91
		2 polymer sprockets 1/2", Z = 14	6002 2RZ	3.5N5.JAB.N91	

On request, we can offer you further options in addition to our standard products (cf. p 57).

Ordering example Example of a reference number: 3.5HB.JAA.N90 - 460

This reference number is for a Conveyor Roller Series 3500, steel, zinc-plated, Ø tube 50 mm, polymer sprocket 1/2", Z = 14, Ø shaft 14 mm, female threaded shaft and reference length 460 mm. The reference length RL can be found on the dimensioned drawing: $RL = EL - 40$. The axial play of the sides of 1 mm and 0.5 mm has already been taken into account. The nominal clearance of your conveyor is 500 mm, which also corresponds to the installation length EL, i. e. the reference length is: $500 - 40 = 460$ mm.

RL	Reference length/Ordering length*
EL	Installation length
AGL	Total length of shaft

*The reference length/ordering length RL does not have any reference edges on the conveyor roller and can therefore not be shown.

The dimensions of the conveyor roller depend on the shaft version and the torque transmission. Below are shown dimensioned drawings for each version.

Dimensions for round belt head with 2 grooves, R = 5 mm

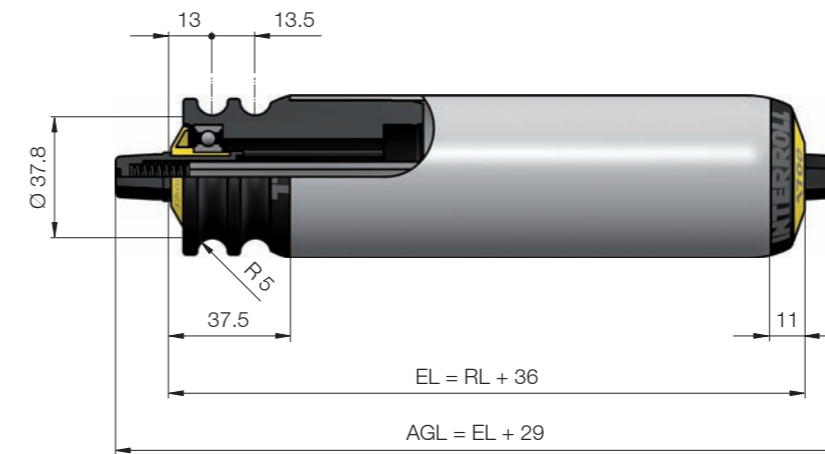

Dimensions for polymer sprocket 1/2", Z = 11

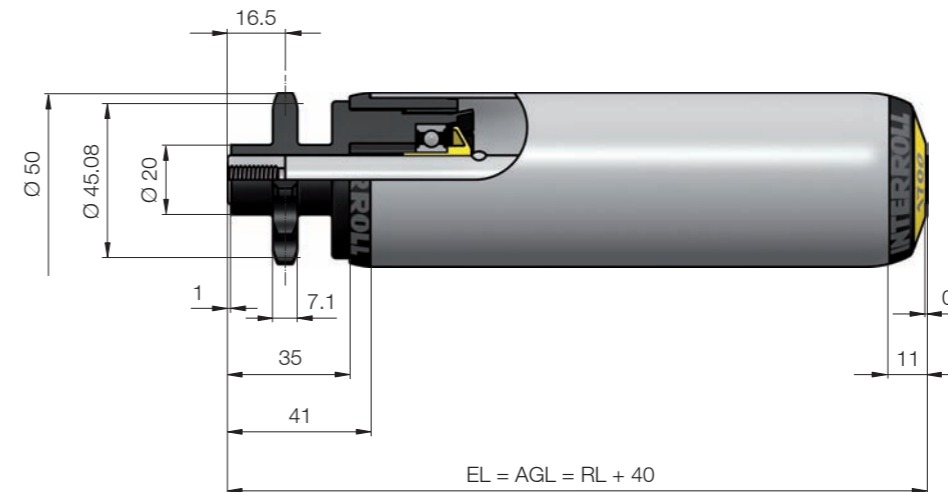

Dimensions

Tapered shaft-shuttle

Female thread



FIXED DRIVE CONVEYOR ROLLER SERIES 3500



Conveyor Rollers
Fixed drive
Series 3500

Low-noise fixed drive, different drive types

Dimensions for polymer sprocket 1/2", Z = 14

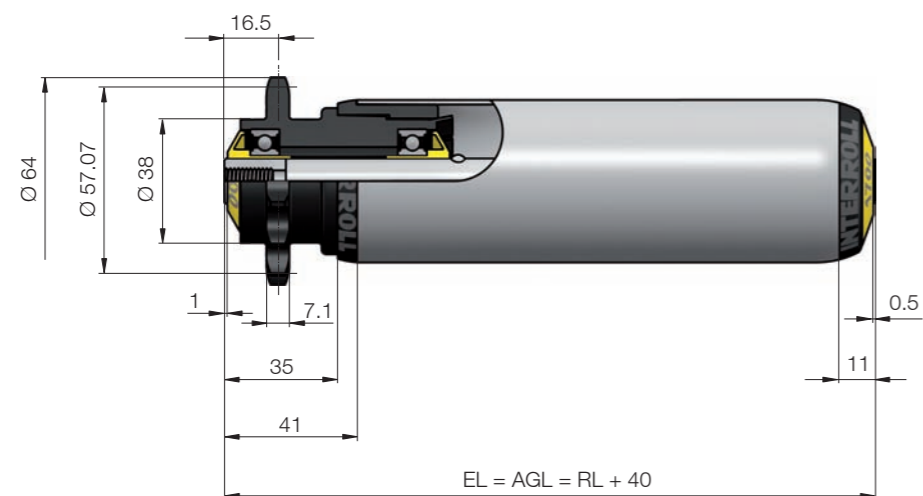

Dimensions for steel sprocket 1/2", Z = 14

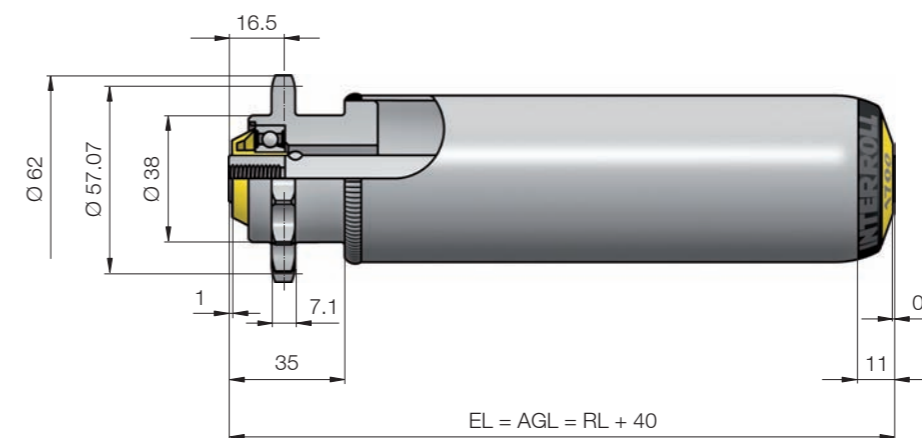

Dimensions for 2 polymer sprockets 1/2", Z = 14

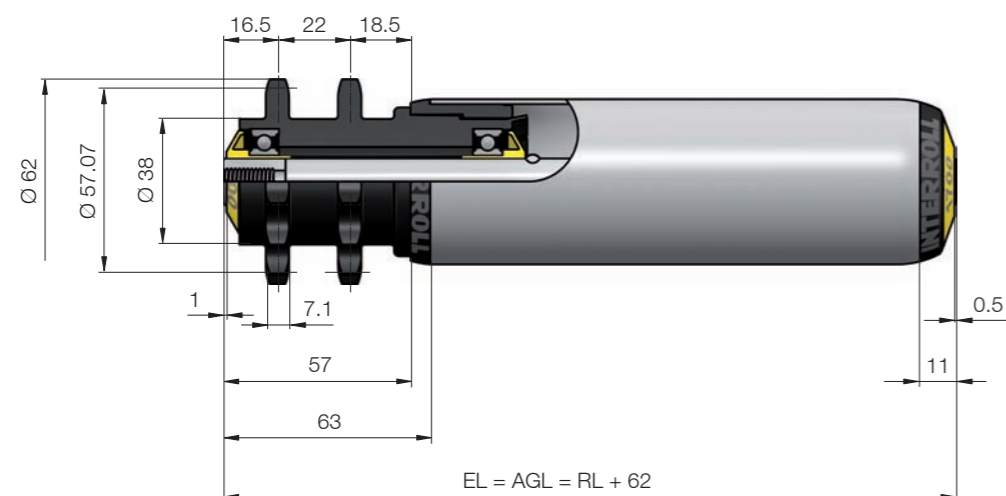

Dimensions for 2 steel sprockets 1/2", Z = 14

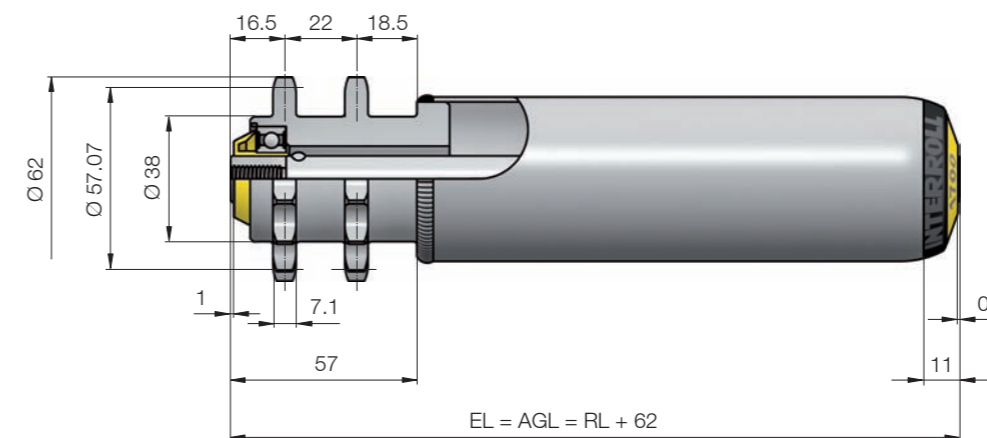



FIXED DRIVE CONVEYOR ROLLER SERIES 3500



Conveyor Rollers
Fixed drive
Series 3500

Low-noise fixed drive, different drive types

Dimensions for PolyVee head with 9 grooves

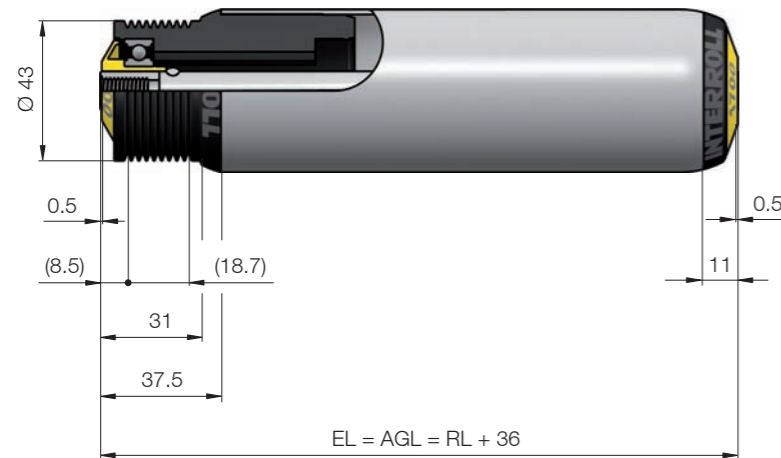

Dimensions for round belt head with 2 grooves

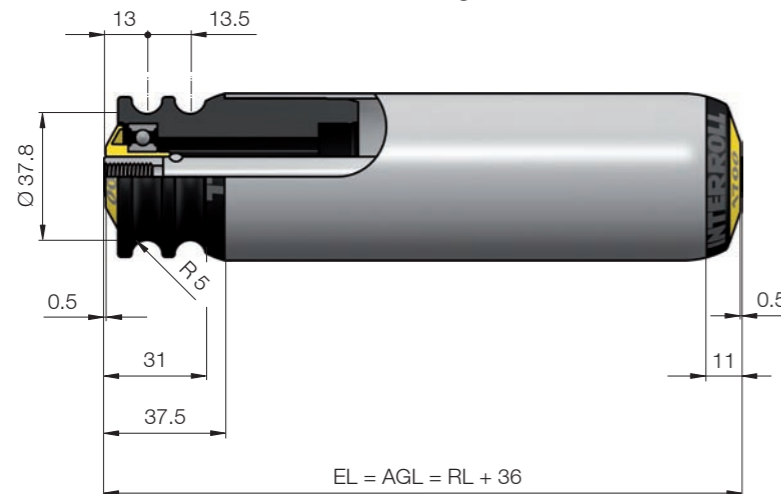

Dimensions for toothed belt head T = 8, Z = 18

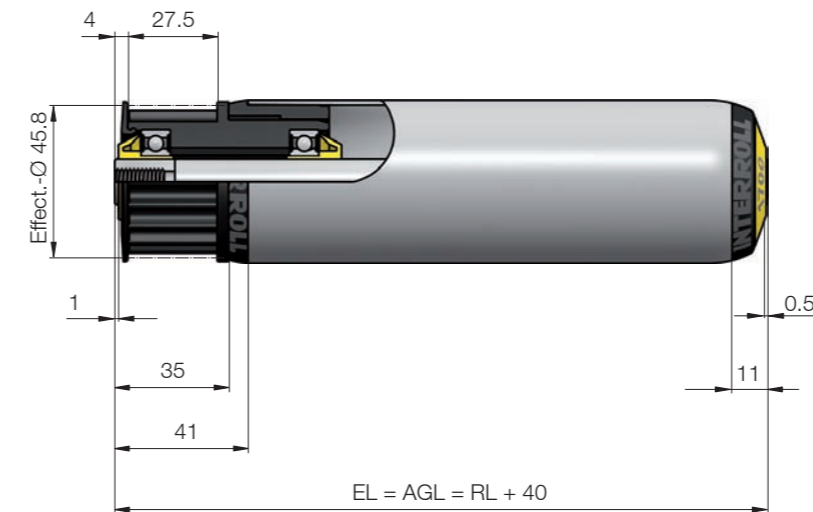

Options

We can offer you the following options in addition to our standard products:

- Antistatic version
- Flanges
- Special surface finish for tubes
 - Hardened
- Tube sleeves
 - Flexible PVC sleeve
 - PU sleeve for Ø50 mm
 - Rubber coating



TAPERED FIXED DRIVE CONVEYOR ROLLER SERIES 3500KXO



Conveyor Rollers
Fixed Drive Curve
Series 3500KXO

Efficient, quiet, simplest construction of a driven roller curve

Product Description

- Customer benefits**
 - Standard product tried and tested a million times over
 - Based on the Universal Conveyor Roller Series 3500
 - Low energy consumption
 - Low net weight due to tapered polypropylene elements
 - Abrasion-proof, sound-reducing, impact-resistant and weather-resistant
 - Tapered technopolymer elements
 - Comprehensive drive versions
 - Round, PolyVee, toothed and flat belts; chain drive 1/2" Z14
- Applications**
 - In-house conveying
 - Gravity or belt drives
 - Curves for crates and containers
- Properties**
 - Sealed precision ball bearing (6002 2RZ)
 - Drive heads made of highly abrasion-proof, viscopolymer polyamide 6.6
 - End cap for tapered elements
- Associated platform**
 - Platform 1700

Technical Data

General technical data		
Max. load capacity, RL independent		500 N
Max. conveyor speed		2 m/s (with chain drive 0.5 m/s)
Temperature range		-5 to +40 °C
Materials		
Bearing housing		Polyamide
Seal		Polypropylene
Ball bearing		Steel 6002 2RZ
Tapered elements		Polypropylene

Product Selection

Female threaded shaft version

Material	Torque transmission	Reference length mm	Min. Ø mm	Max. Ø mm	Tube	Ball bearing	Shaft
							Reference number Ø 14 mm (M8 x 15)
Steel, zinc-plated	Round belt head	250	55.6	71.2	6002 2RZ	3.5PO.HE2.N7X	
		300	52.5	71.2	6002 2RZ	3.5PO.HF3.N7X	
		350	55.6	77.6	6002 2RZ	3.5PO.HE3.N7X	
		400	52.5	77.6	6002 2RZ	3.5PO.HF4.N7X	
		450	55.6	84.0	6002 2RZ	3.5PO.HE4.N7X	
		500	52.5	84.0	6002 2RZ	3.5PO.HF5.N7X	
		550	55.6	90.4	6002 2RZ	3.5PO.HE5.N7X	
		600	52.5	90.4	6002 2RZ	3.5PO.HF6.N7X	
		650	55.6	96.8	6002 2RZ	3.5PO.HE6.N7X	
		700	52.5	96.8	6002 2RZ	3.5PO.HF7.N7X	
		750	55.6	103.2	6002 2RZ	3.5PO.HE7.N7X	
		800	52.5	103.2	6002 2RZ	3.5PO.HF8.N7X	
	850	55.6	109.6	6002 2RZ	3.5PO.HE8.N7X		
	PolyVee head	250	55.6	71.2	6002 2RZ	3.5PA.HE2.N7X	
		300	52.6	71.2	6002 2RZ	3.5PA.HF3.N7X	
		350	55.6	77.6	6002 2RZ	3.5PA.HE3.N7X	
		400	52.5	77.6	6002 2RZ	3.5PA.HF4.N7X	
		450	55.6	84.0	6002 2RZ	3.5PA.HE4.N7X	
		500	52.5	84.0	6002 2RZ	3.5PA.HF5.N7X	
		550	55.6	90.4	6002 2RZ	3.5PA.HE5.N7X	
		600	52.5	90.4	6002 2RZ	3.5PA.HF6.N7X	
		650	55.6	96.8	6002 2RZ	3.5PA.HE6.N7X	
		700	52.5	96.8	6002 2RZ	3.5PA.HF7.N7X	
		750	55.6	103.2	6002 2RZ	3.5PA.HE7.N7X	
800		52.5	103.2	6002 2RZ	3.5PA.HF8.N7X		
2 polymer sprockets 1/2", Z = 14	250	55.6	71.2	6002 2RZ	3.5XQ.HE2.N91		
	300	52.5	71.2	6002 2RZ	3.5XQ.HF3.N91		
	350	55.6	77.6	6002 2RZ	3.5XQ.HE3.N91		
	400	52.5	77.6	6002 2RZ	3.5KY.HF4.N91		
	450	55.6	84.0	6002 2RZ	3.5XQ.HE4.N91		
	500	52.5	84.0	6002 2RZ	3.5XQ.HF5.N91		
	550	55.6	90.4	6002 2RZ	3.5XQ.HE5.N91		
	600	52.5	90.4	6002 2RZ	3.5XQ.HF6.N91		
	650	55.6	96.8	6002 2RZ	3.5XQ.HE6.N91		
	700	52.5	96.8	6002 2RZ	3.5XQ.HF7.N91		
	750	55.6	103.2	6002 2RZ	3.5XQ.HE7.N91		
	800	52.5	103.2	6002 2RZ	3.5XQ.HF8.N91		
	850	55.6	109.6	6002 2RZ	3.5XQ.HE8.N91		
	900	52.5	109.6	6002 2RZ	3.5XQ.HF9.N91		

Standards



TAPERED FIXED DRIVE CONVEYOR ROLLER SERIES 3500KXO



Conveyor Rollers
Fixed Drive Curve
Series 3500KXO

Efficient, quiet, simplest construction of a driven roller curve

Ordering example Example of a reference number: **3.5PO.HF5.N7X - 464**

This reference number is for a Conveyor Roller Series 3500KXO, steel, zinc-plated, round belt head, reference length 500 mm, Ø shaft 14 mm, female threaded shaft and reference length 464 mm. The reference length RL can be found on the dimensioned drawing: $RL = EL - 36$. The axial play of 0.5 mm per side has already been taken into account. The nominal clearance of your conveyor is 500 mm, which also corresponds to the installation length EL, i. e. the reference length is: $500 - 36 = 464$ mm.

Dimensions	RL	Reference length/Ordering length*
	EL	Installation length
	AGL	Total length of shaft

*The reference length/ordering length RL does not have any reference edges on the conveyor roller and can therefore not be shown.

Dimensions tapered elements with 2 polymer sprockets 1/2", Z=14

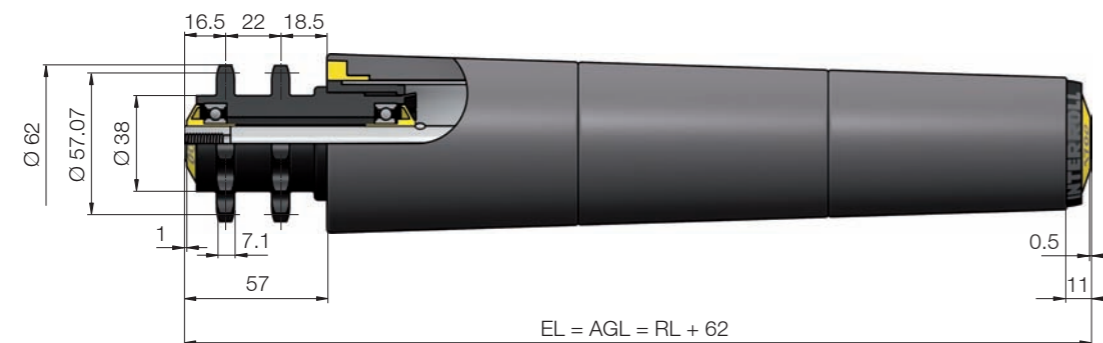

Dimensions for tapered elements with round belt head

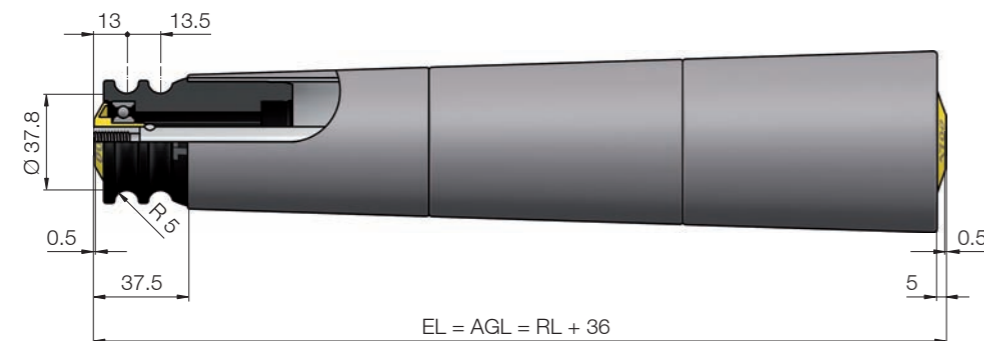

Dimensions for tapered elements with PolyVee head

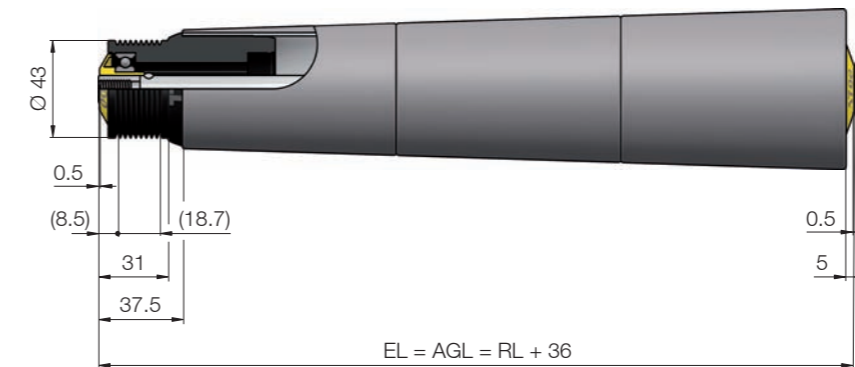

Options

We can offer you the following options in addition to our standard products:

- Internal curve radius 650 mm
- Extended inner tube



FIXED DRIVE CONVEYOR ROLLER SERIES 3560



Conveyor Rollers
Fixed drive
Series 3560

Stable fixed drive for small roller pitches

Product Description

- Customer benefits**
 - Stable, fixed drive conveyor roller
 - Welded steel sprockets, steel tube 60 x 3 mm
 - Conveyor reinforced by captive shaft
 - Female threaded shaft Ø 17 mm
 - Small pitches possible
 - Ø 60 mm and tangential drive
 - Gentle lateral pushing of the materials to be conveyed
 - Rounded tube ends
- Applications**
 - In-house driven conveyance of heavy material to be conveyed for which small roller pitches are required
 - Pallets, steel containers without continuous runners
- Properties**
 - Sealed precision ball bearing (6003 2RZ)
 - Steel sprockets, welded to tube
 - Zinc-plated as a component after welding
- Associated platform**
 - Platform 1700

Technical Data

General technical data	
Max. load capacity	3,000 N
Max. conveyor speed	1.2 m/s
Temperature range	-5 to +40 °C
Materials	
Bearing housing	Polyamide
Drive head	Steel
Seal	Polyamide
Ball bearing	Steel 6003 2RZ

The load capacity depends on the length of the roller.

Load capacity

Female threaded shaft version

Tube material	Ø Tube mm	Ø Shaft mm	Max. load capacity in N with an installation length of mm					
			200	900	1,000	1,100	1,300	1,500
Steel, zinc-plated	60 x 3	17	3,000	3,000	2,910	2,160	1,290	830



FIXED DRIVE CONVEYOR ROLLER SERIES 3560



Conveyor Rollers
Fixed drive
Series 3560

Stable fixed drive for small roller pitches

Product Selection

Standards Female threaded shaft version

Tube	Ball bearing	Shaft
Material	Ø mm	Torque transmission
Steel, zinc-plated	60 x 3.0	Steel sprocket 5/8", Z = 13 2 steel sprockets 5/8", Z = 13
		Reference number
		Ø 17 mm (M12 x 20)
		3.56W.JDC.RAJ
		3.56W.JDB.RAL

Ordering information Please state in addition to the reference number the reference length RL and optionally the dimensions for the tube sleeve.

Ordering example

Example of a reference number: 3.56A.JDC.RAJ - 464

This reference number is for a Conveyor Roller Series 3560, Ø tube 60 mm, steel sprocket 5/8", Z = 13, Ø shaft 17 mm, female threaded shaft and reference length 464 mm. The reference length RL can be found on the dimensioned drawing: $RL = EL - 36$. The axial play of the sides of 1 mm and 0.5 mm has already been taken into account. The nominal clearance of your conveyor is 500 mm, which also corresponds to the installation length EL, i. e. the reference length is: $500 - 36 = 464$ mm.

Dimensions	RL	Reference length/Ordering length*
	EL	Installation length
	AGL	Total length of shaft

*The reference length/ordering length RL does not have any reference edges on the conveyor roller and can therefore not be shown.

Dimensions for steel sprocket

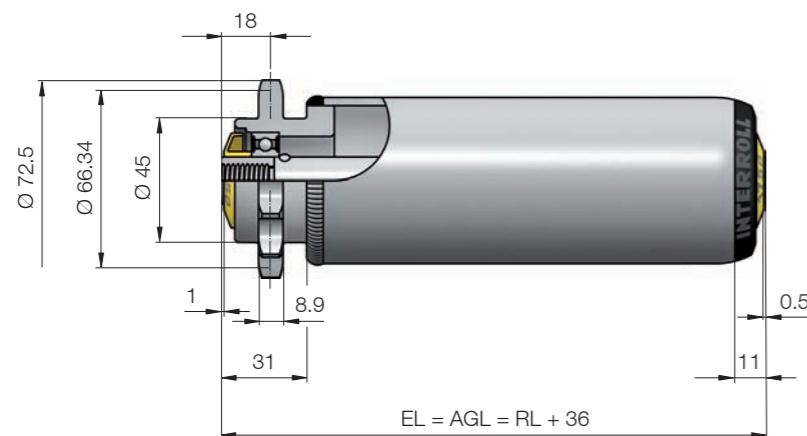

Dimensions for 2 steel sprockets

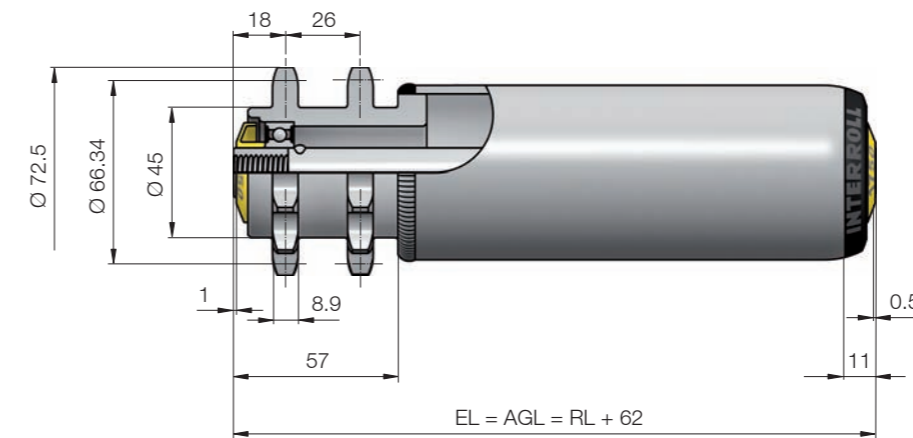

Options

We can offer you the following options in addition to our standard products:

- Flanges
- Tube sleeves
 - Flexible PVC sleeve
 - Rubber coating



FRICION CONVEYOR ROLLER SERIES 3800



Conveyor Rollers
Friction drive
Series 3800

Accumulation with gentle accumulation pressure

Product Description

- Customer benefits**
 - Exceptionally low-noise operation
 - Polyamide or POM drive heads (alternatively made of steel)
 - Replaceable drive heads for fixed and friction drives
 - Fixed bearing housing for attachable drive heads
 - Weight-dependent accumulation pressure and weight-dependent conveyance
 - Radial friction coupling in the conveyor roller
 - Comprehensive drive versions
 - Toothed and flat belts; chain drive 1/2" Z9, Z11, Z14
- Applications**
 - Accumulation operation with gentle accumulation pressure of medium-heavy materials to be conveyed
 - Drums, tyres, boxes
- Properties**
 - Sealed precision ball bearing (6002 2RZ)
 - Series 3800 based on Series 1700
- Associated platform**
 - Platform 1700

Technical Data

General technical data

Max. load capacity	500 N
Max. conveyor speed	0.5 m/s
Temperature range	-5 to +40 °C

Materials

Bearing housing	Polyamide
Drive head	Polyamide, POM, steel
Friction coupling	Polyamide
Seal	Polypropylene
Ball bearing	Steel 6002 2RZ

The load capacity depends on the shaft version, the tube diameter, the length of the roller and the torque transmission.

Load capacity

Female threaded shaft version

Tube material	Ball bearing	Torque transmission	Ø Tube mm	Ø Shaft mm	Max. load capacity in N with an installation length of mm						
					200	400	600	800	1000	1200	1400
PVC	6002 2RZ	Polymer sprocket Z = 11	50 x 2.8	14	300	300	110	40	-	-	-
		1 & 2 polymer sprockets Z = 14	50 x 2.8	14	350	265	90	50	-	-	-
		Toothed belt head Z = 18									
Steel, zinc-plated	6002 2RZ	Polymer sprocket Z = 11	50 x 1.5	14	300	300	300	300	300	290	250
		1 & 2 polymer sprockets Z = 14	50 x 1.5	14	500	500	500	500	500	500	500
		Toothed belt head Z = 18	50 x 1.5								
		1 & 2 polymer sprockets Z = 14	60 x 1.5	14	500	500	500	500	500	500	500
		Toothed belt head Z = 18	60 x 1.5								
		1 & 2 steel sprockets Z = 14	50 x 1.5	14	500	500	500	500	500	500	500
			60 x 1.5		500	500	500	500	500	500	500



FRICION CONVEYOR ROLLER SERIES 3800



Conveyor Rollers
Friction drive
Series 3800

Accumulation with gentle accumulation pressure

Product Selection

Standards Female threaded shaft version

Material	Ø mm	Torque transmission	Ball bearing	Shaft Reference number Ø 14 mm (M8 x 15)
PVC	50 x 2.8	Polymer sprocket 1/2", Z = 14	6002 2RZ	3.8M3.SAA.N90
		Polymer sprocket 1/2", Z = 11	6002 2RZ	3.8M1.SAA.N90
		2 polymer sprockets 1/2", Z = 14	6002 2RZ	3.8M5.SAA.N91
Steel, zinc-plated	50 x 1.5	Toothed belt head	6002 2RZ	3.8B2.JAA.N90
		Steel sprocket 1/2", Z = 14	6002 2RZ	3.80R.JAA.N7S*
		Steel sprocket 1/2", Z = 14	6002 2RZ	3.8J6.JAA.N90
		Polymer sprocket 1/2", Z = 14	6002 2RZ	3.8L7.JAA.N90
		Polymer sprocket 1/2", Z = 11	6002 2RZ	3.8L2.JAA.N90
		2 steel sprockets 1/2", Z = 14	6002 2RZ	3.8K9.JAA.N91
		2 polymer sprockets 1/2", Z = 14	6002 2RZ	3.8LC.JAA.N91

*Adjustable friction

Ordering example Example of a reference number: 3.8L7.JAA.N90 - 460

This reference number is for a Conveyor Roller Series 3800, steel, zinc-plated, Ø tube 50 mm, polymer sprocket 1/2", Z = 14, Ø shaft 14 mm, female threaded shaft and reference length 460 mm. The reference length RL can be found on the dimensioned drawing: $RL = EL - 40$. The axial play of the sides of 1 mm and 0.5 mm has already been taken into account. The nominal clearance of your conveyor is 500 mm, which also corresponds to the installation length EL, i. e. the reference length is: $500 - 40 = 460$ mm.

Dimensions	RL	Reference length/Ordering length*
	EL	Installation length
	AGL	Total length of shaft

*The reference length/ordering length RL does not have any reference edges on the conveyor roller and can therefore not be shown.

Dimensions for polymer sprocket 1/2", Z = 11

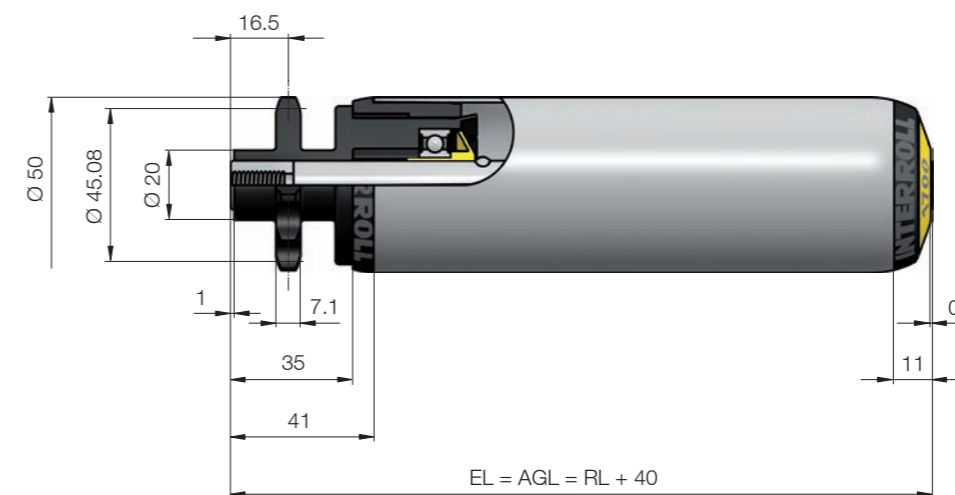

Dimensions for polymer sprocket 1/2", Z = 14

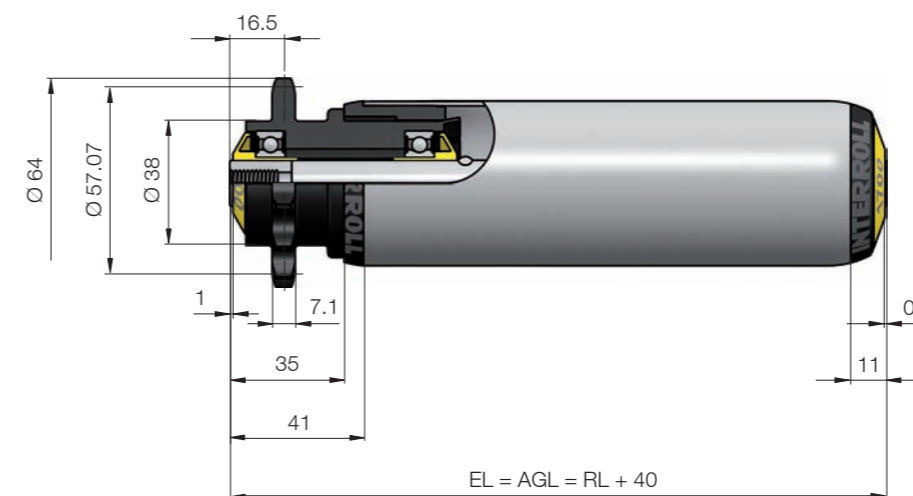



FRICION CONVEYOR ROLLER SERIES 3800



Conveyor Rollers
Friction drive
Series 3800

Accumulation with gentle accumulation pressure

Dimensions for 2 polymer sprockets 1/2", Z = 14

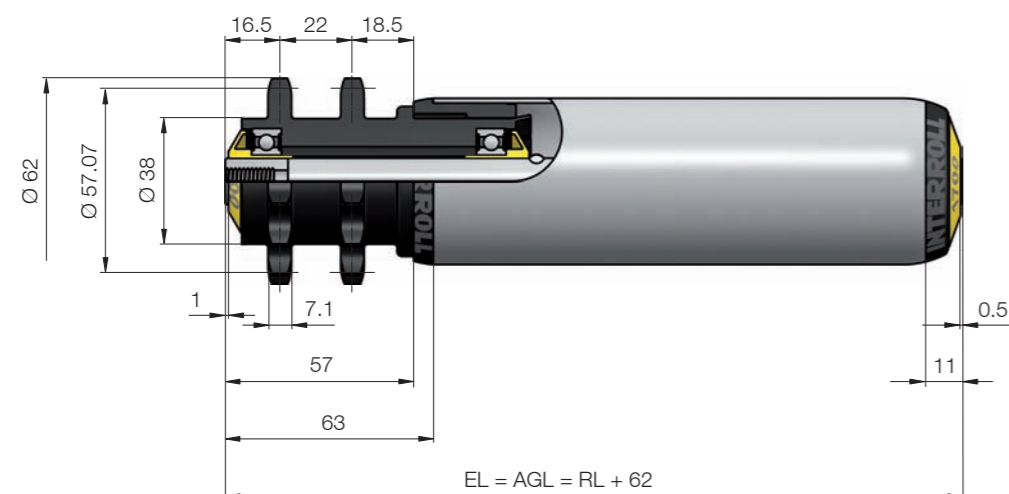

Dimensions for steel sprocket 1/2", Z = 14

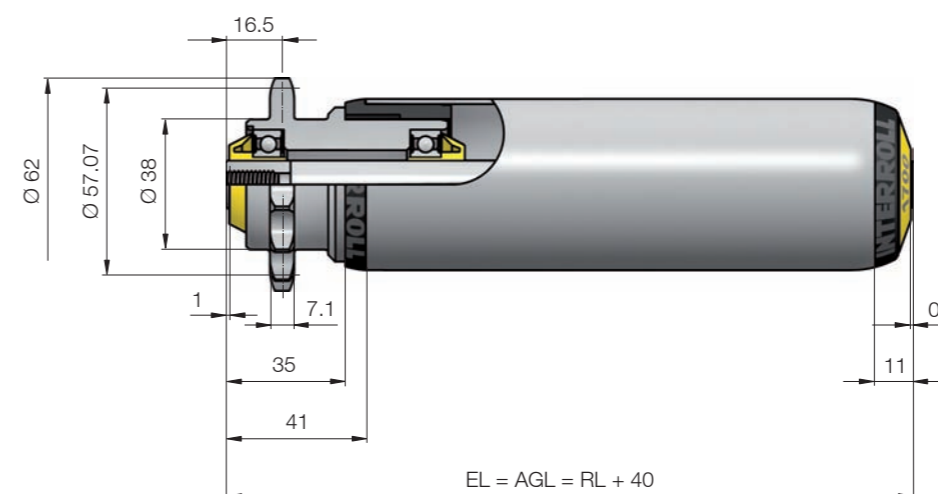

Dimensions for toothed belt head T = 8, Z = 18

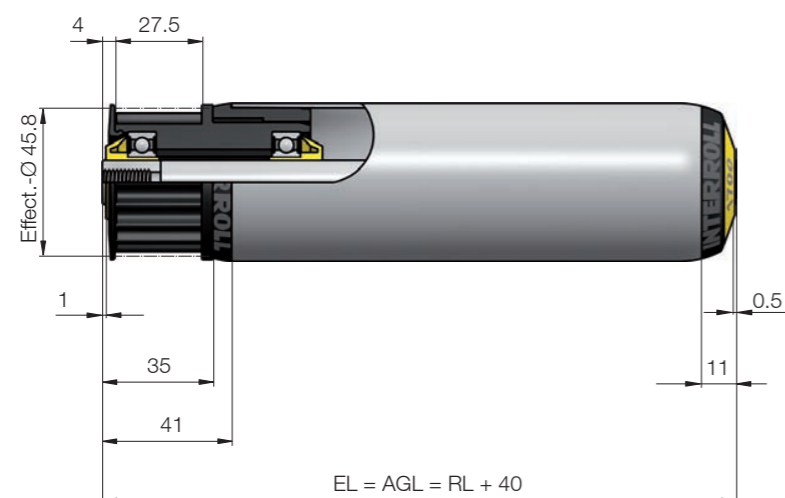

Dimensions for 2 steel sprockets 1/2", Z = 14

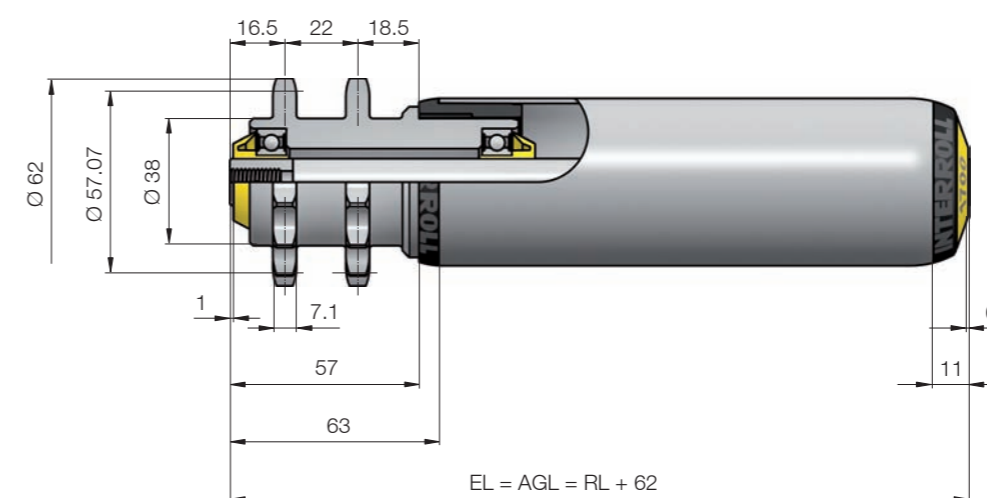

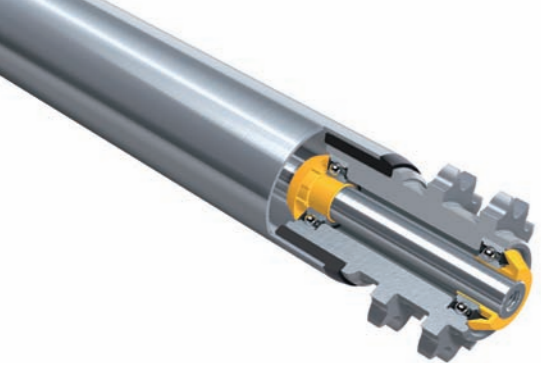

FRICION CONVEYOR ROLLER SERIES 3800

Accumulation with gentle accumulation pressure



Conveyor Rollers
Friction drive
Series 3800

Dimensions for steel sprocket 1/2", Z = 14 (adjustable friction)

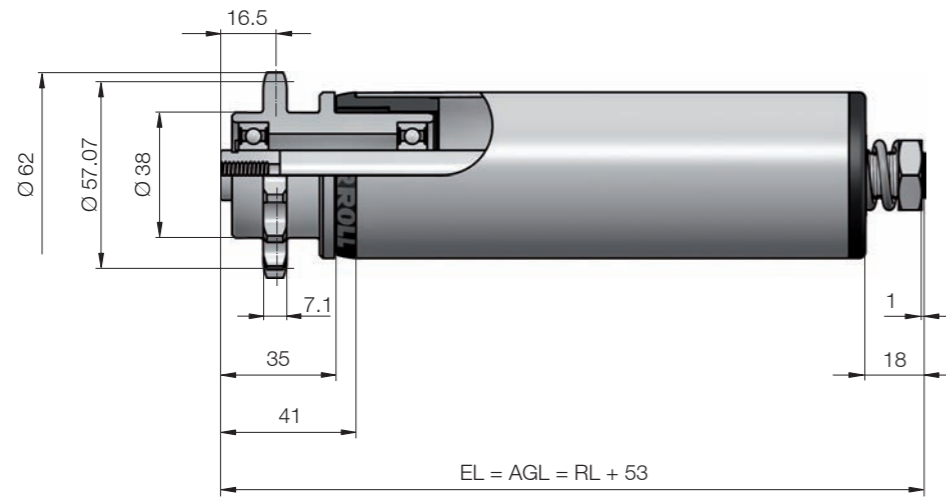

Options

We can offer you the following options in addition to our standard products:

- Antistatic version



DOUBLE FRICTION CONVEYOR ROLLER SERIES 3860



Conveyor Rollers
Friction drive
Series 3860

Accumulation with increased conveyor forces

Product Description

- Customer benefits**
 - Simultaneous conveyance and accumulation with one drive
 - Mechanical solution with friction coupling in the conveyor roller
 - Weight-dependent accumulation pressure and weight-dependent conveyance
 - Radial friction coupling in the conveyor roller
 - Increased conveying forces for critical materials to be conveyed
 - Radial friction coupling at both sides joined by coupling tube
 - Comprehensive drive versions
 - Roller-to-roller and tangential chain drive
- Applications**
 - In-house accumulation roller conveyors with increased accumulation pressure
 - Heavy materials to be conveyed
 - Pallets
 - Steel containers
- Properties**
 - Sealed precision ball bearing (6003 2RZ)
 - Steel sprockets, welded to tube
 - Zinc-plated as a component after welding
- Associated platform**
 - Platform 1700

Technical Data

General technical data

Max. load capacity	1,300 N
Max. conveyor speed	0.5 m/s
Temperature range	-5 to +40 °C

Materials

Bearing housing	Polyamide
Drive head	Steel
Friction coupling	Polyamide
Seal	Polyamide
Ball bearing	Steel 6003 2RZ

The load capacity depends on the length of the roller.

Load capacity

Female threaded shaft version

Tube material	Ø Tube mm	Max. load capacity in N with an installation length of mm		
		200	1,300	1,500
Steel, zinc-plated	60 x 3	1,300	1,300	640

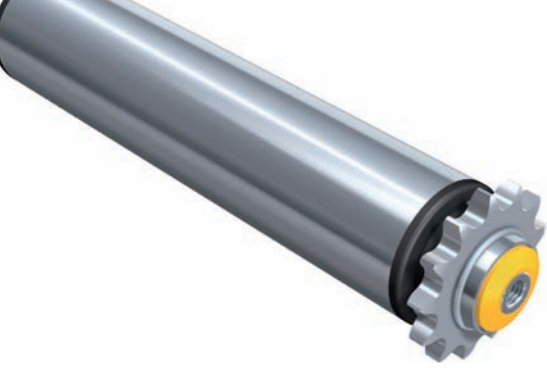

DOUBLE FRICTION CONVEYOR ROLLER SERIES 3860



Conveyor Rollers
Friction drive
Series 3860

Accumulation with increased conveyor forces

Product Selection

Standards Female threaded shaft version

Tube	Ball bearing	Shaft
Material	Ø mm	Torque transmission
Steel, zinc-plated	60 x 3.0	Steel sprocket 5/8", Z = 13 2 steel sprockets 5/8", Z = 13
		6003 2RZ
		Reference number
		Ø 17 mm (M12 x 20)
		3.86A.JBU.RCB
		3.86A.JBV.RCD

Ordering example Example of a reference number: 3.86A.JBU.RCB - 461

This reference number is for a Conveyor Roller Series 3860, Ø tube 60 mm, steel sprocket 5/8", Z = 13, Ø shaft 17 mm, female threaded shaft and reference length 461 mm. The reference length RL can be found on the dimensioned drawing: $RL = EL - 39$. The axial play of 0.5 mm per side has already been taken into account. The nominal clearance of your conveyor is 500 mm, which also corresponds to the installation length EL, i. e. the reference length is: $500 - 39 = 461$ mm.

Dimensions

RL	Reference length/Ordering length
EL	Installation length
AGL	Total length of shaft

Dimensions for steel sprocket , Z = 13

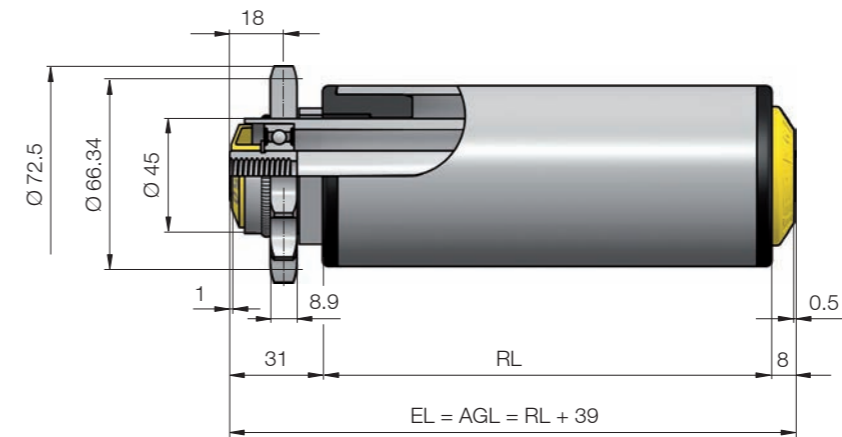

Dimensions for 2 steel sprockets , Z = 13

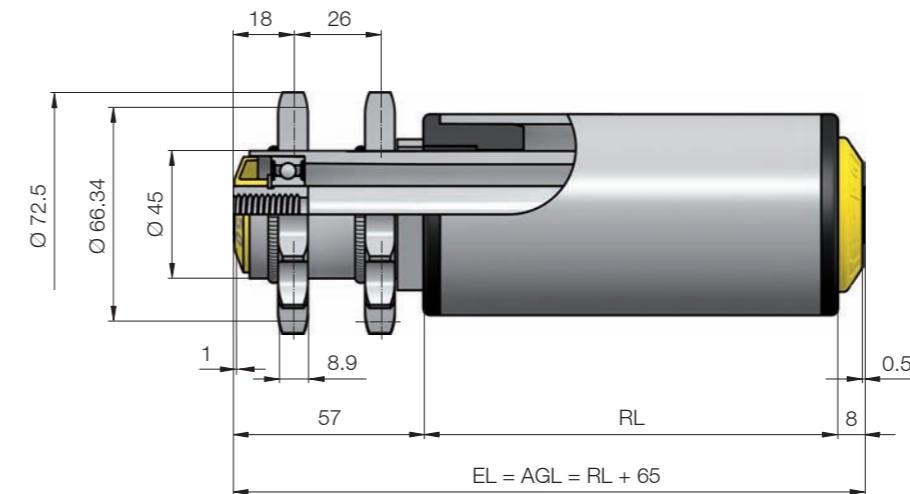



DOUBLE FRICTION CONVEYOR ROLLER SERIES 3870



Conveyor Rollers
Friction drive
Series 3870

Accumulation with increased conveyor forces

Product Description

- Customer benefits**
 - Simultaneous conveyance and accumulation with one drive
 - Mechanical solution with friction coupling in the conveyor roller
 - Weight-dependent accumulation pressure and weight-dependent conveyance
 - Radial friction coupling in the conveyor roller
 - Increased conveying forces for critical materials to be conveyed
 - Radial friction coupling at both sides joined by coupling tube
 - Comprehensive drive versions
 - Roller-to-roller and tangential chain drive
- Applications**
 - In-house accumulation roller conveyors with increased accumulation pressure
 - Medium-heavy materials to be conveyed
 - Boxes
 - Containers
 - Trays
- Properties**
 - Sealed precision ball bearing (6002 2RZ)
 - Polyamide steel sprockets, press-fitted onto the tube
- Associated platform**
 - Platform 1700

Technical Data

General technical data

Max. load capacity	500 N
Max. conveyor speed	0.5 m/s
Temperature range	-5 to +40 °C

Materials

Bearing housing	Polyamide
Drive head	Polyamide
Friction coupling	Polyamide
Seal	Polyamide
Ball bearing	Steel 6002 2RZ

The load capacity depends on the length of the roller.

Load capacity

Female threaded shaft version

Tube material	Ball bearing	Torque transmission	Ø Tube mm	Ø Shaft mm	Max. load capacity in N with an installation length of mm			
					200	1,100	1,300	1,500
Steel, zinc-plated	6002 2RZ	at will	50 x 1.5	14	500	500	440	280



DOUBLE FRICTION CONVEYOR ROLLER SERIES 3870

Accumulation with increased conveyor forces

Product Selection

Standards Female threaded shaft version

Material	Ø mm	Torque transmission	Ball bearing	Shaft Reference number Ø 14 mm (M8 x 15)
Steel, zinc-plated	50 x 1.5	Polymer sprocket 1/2", Z = 14	6002 2RZ	3.84P.JPB.N9C
		2 polymer sprockets 1/2", Z = 14	6002 2RZ	3.84V.JPB.N9L

Ordering example Example of a reference number: 3.84P.JPB.N9C - 465

This reference number is for a Conveyor Roller Series 3870, Ø tube 50 mm, polymer sprocket 1/2", Z = 14, Ø shaft 14 mm, female threaded shaft and reference length 465 mm. The reference length RL can be found on the dimensioned drawing: $RL = EL - 35$. The axial play of the sides of 1 mm and 0.5 mm has already been taken into account. The nominal clearance of your conveyor is 500 mm, which also corresponds to the installation length EL, i. e. the reference length is: $500 - 35 = 465$ mm.

Dimensions

RL	Reference length/Ordering length
EL	Installation length
AGL	Total length of shaft

Dimensions for polymer sprocket 1/2", Z = 14

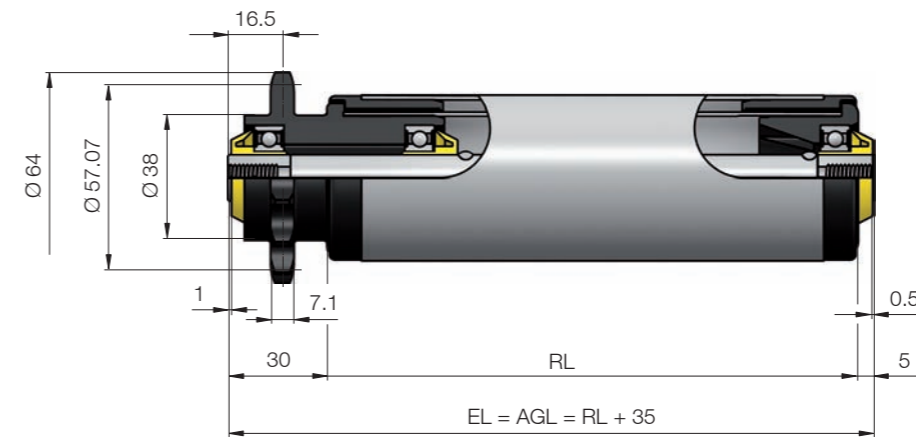

Dimensions for 2 polymer sprockets 1/2", Z = 14

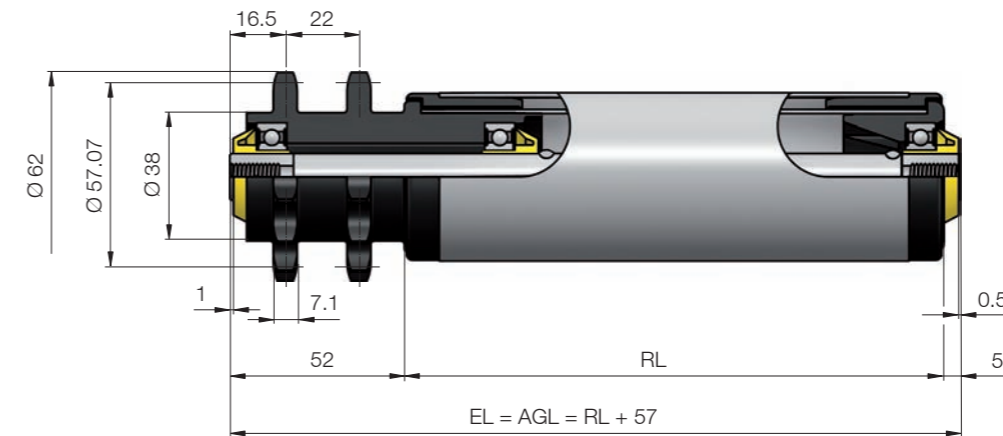

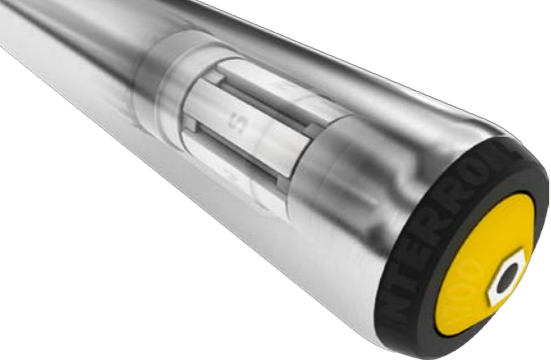

MAGNETIC SPEED CONTROLLER 50



Speed
Controller

Controlled Speed

Product Description

- Customer benefits**
- Purely mechanical construction
 - No cabling or control required
 - No gear box
 - Smooth start for materials from 500 g
 - Contact-free braking function with eddy-current brake
 - Maintenance-free, no wear, same service life as standard conveyor rollers
 - High braking power
 - Container mix with up to 35 kg starts up safely and, at the same time, runs at a controlled speed
 - Based on Series 1700 conveyor roller
 - Tried and tested a million times over
 - Unique external marking for identification
 - No danger of confusion with rollers
 - 51 mm tube diameter for required higher surface to the carrying roller (54 mm with PU sleeve)
 - No fastening brackets with additional profile holes required
 - Direction-independent operation
 - Assembly errors are eliminated
 - No external emissions (e.g. magnetism)
 - No effect on sensitive materials, such as in the field of electronics
 - PU sleeve for smooth containers
 - Even critical materials are decelerated reliably

The new speed controller MSC 50 provides gravity roller conveyors with significantly improved functionality, resulting in higher process reliability. Lightweight materials start up reliably, there is no need for laborious manual pushing, and employees contribute in a value-adding manner. Optimal braking of heavy materials, thereby significantly increasing safety in the workplace and preventing expensive damage to sensitive goods. With MSC 50, new installations can be planned perfectly, and existing installations can be retrofitted without any problems.

- Applications**
- All gravity roller conveyors
 - Sorting endpoints
 - Spiral conveyors
 - Helical conveyors

- Properties**
- Zinc-plated steel tube
 - Form-fit axial fixing of bearing housing, ball bearing and seal
 - Sealed, oiled precision ball bearing 6002 2RZ
 - Always antistatic

- Associated platform**
- Platform 1700

Technical Data

General technical data

Max. load capacity	500 N
Max. conveying speed (infeed speed)	2 m/s
Weight of materials	0.5 to 35 kg
Min./max. installation length (EL)	210 / 1400 mm
Ambient temperature range	+5 to +40 °C

Materials

Bearing housing	Polyamide
Seal	Polyamide
Ball bearing	Steel 6002 2RZ, oiled
Magnets	Neodyme N45
Tube	Steel, zinc-plated
Shaft	Steel, stainless

Versions of the MSC 50

Tube material	Shaft design	Sleeve	Ball bearing	Tube	Shaft
Steel, zinc-plated	Spring-loaded shaft	-	6002 2RZ	51 x 2	11 hex
		PU, 2 mm	6002 2RZ	50 x 1.5	11 hex
	Fixed shaft	-	6002 2RZ	51 x 2	11 hex
		PU, 2 mm	6002 2RZ	50 x 1.5	11 hex
	Female thread	-	6002 2RZ	51 x 2	11 hex
		PU, 2 mm	6002 2RZ	50 x 1.5	11 hex

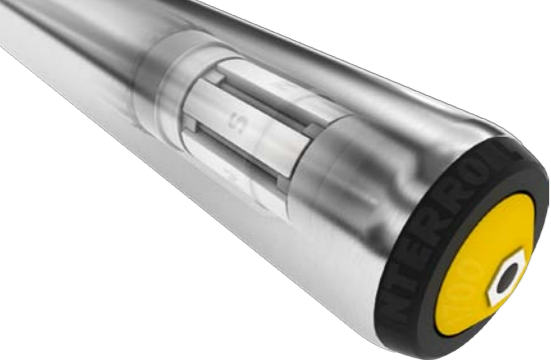

MAGNETIC SPEED CONTROLLER 50



Speed Controller

Controlled Speed

Product Selection

Standards

Spring-loaded shaft

Tube	Ball bearing	Shaft
Material	Ø mm	Sleeve
Steel, zinc-plated	50 x 1.5	PU, 2 mm
	51 x 2	-
	6002 2RZ	4.7AA.J4Z.WAH
	6002 2RZ	4.7AA.J51.WAH

Fixed shaft

Tube	Ball bearing	Shaft
Material	Ø mm	Sleeve
Steel, zinc-plated	50 x 1.5	PU, 2 mm
	51 x 2	-
	6002 2RZ	4.7AA.J4Z.WAN
	6002 2RZ	4.7AA.J51.WAN

Female threaded shaft

Tube	Ball bearing	Shaft
Material	Ø mm	Sleeve
Steel, zinc-plated	50 x 1.5	PU, 2 mm
	51 x 2	-
	6002 2RZ	4.7AA.J4Z.WBC
	6002 2RZ	4.7AA.J51.WBC

Dimensions

EL Installation length
AGL Total length of shaft

Dimensions for spring-loaded shaft / fixed shaft

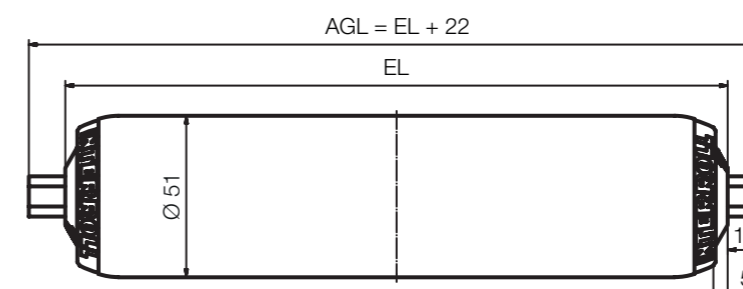

Dimension for female thread

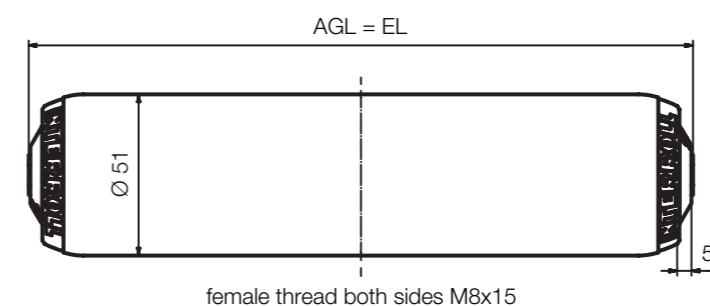

Dimensions with PU sleeve

The MSC 50 with PU sleeve has a diameter of 54 mm. Other dimensions depending on shaft design.

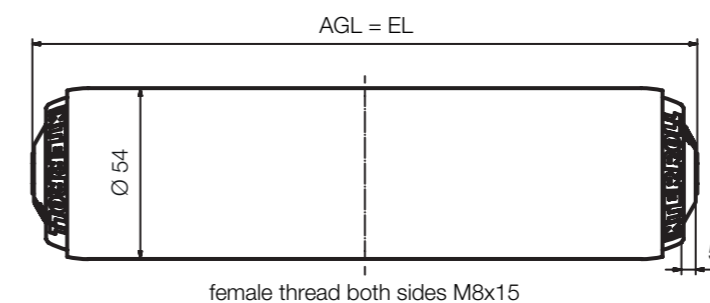



ROLLERDRIVE OVERVIEW

	BT100	EC310	EC310 for refrigerated applications	EC310 IP66
Mechanical power	11 W	32 W	32 W	32 W
Conveyor speed	0.1 to 0.9 m/s	0.01 to 1.75m/s	0.04 to 0.79 m/s	0.01 to 0.98 m/s
Commutation type	Mechanical	Electronic, internal	Electronic, internal	Electronic, internal
Controls		DriveControl 20 p 106 DriveControl 54 p 108 ZoneControl p 110	DriveControl 20 p 106 DriveControl 54 p 108 ZoneControl p 110	DriveControl 20 p 106 DriveControl 54 p 108 ZoneControl p 110
Drive concepts				
Round belt	✓	✓	✓	✓
PolyVee belt		✓	✓	✓
Toothed belt		✓		
	see page 88	see page 92	see page 92	see page 100



ROLLERDRIVE BT100

Low-noise RollerDrive with simple control

Product Description

- Mechanical commutation (brush motor)
- Integral overheat protection
- 6 velocity variants
- Open strands

Technical Data

General technical data	
Mechanical power	13 W
Max. noise level	50 dB(A) (application-dependent)
Possible static bearing load	
Slave side: Female thread / Spring-loaded shaft	1100 N
Slave side:	
Round belt head with female thread / with spring-loaded shaft	350 N
Electrical data	
Rated voltage	24 V DC
Permissible voltage range	16 to 28 V DC
Idle current	max. 0.6 A
Max. continuous current	0.8 A (0.6 A for a reduced motor drive)
Max. start-up current	4.0 A (2.2 A for a reduced motor drive)
Permissible voltage undulation	< 5 %, recommended: < 1 %
Protection rate	IP54
Dimensions	
Tube diameter / Wall thickness	50 x 1.5 mm; 51 x 2 mm
Max. reference length	1,500 mm
Ambient conditions	
Ambient temperature in operation	0 to +40 °C
Ambient temperature during transport and storage	-20 to +75 °C
Max. air humidity	90 %, non-condensing

Product Selection

The following tables provide an overview of the possible versions.

Gear stage versions	Gears	Gear / Motor ratio	Max. conveyor speed	Rated torque	Start-up torque
			m/s	Nm	Nm
Two-stage	9:1	0.9	0.31	1.54	
	9:1, reduced	0.7	0.31	1.22	
	21:1	0.4	0.65	3.23	
Three-stage	30:1	0.3	0.92	4.62	
	37:1	0.2	1.14	5.70	
	37:1, reduced	0.1	1.14	4.50	

The above motor data does not apply to the reduced versions.

Tube material	Stainless steel; steel, zinc-plated; steel, chrome-plated; aluminium
Motor shaft	11 mm hex with male thread M12 x 1.5
Motor shaft material	Stainless steel; steel, zinc-plated
Tube sleeve	PVC hose 2 / 5 mm, PU hose 2 mm, rubber coating 2 to 5 mm, tapered tube sleeves
Length of motor cable	5 m

Further versions

Reference number

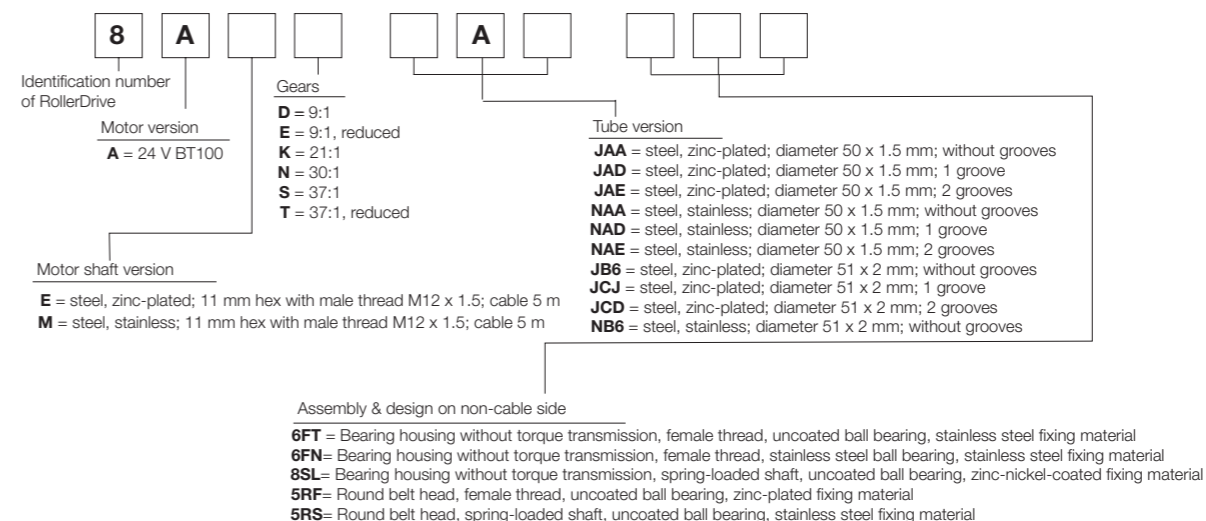

Not all criteria can be combined: please ask about tapered tube designs and tube coatings



ROLLERDRIVE BT100

Low-noise RollerDrive with simple control

Dimensions and Connections

Dimensions

The dimensions depend on the shaft and counter bearing selected. The reference length/ordering length RL does not have any reference edges on the conveyor roller and can therefore not be shown. The installation (EL) corresponds to the clearance between the side profiles. All dimensions in mm.

Motor side	Slave side	
11 mm hex M12 x 1.5	11 mm hex spring-loaded shaft	Female thread M8
	Straight	

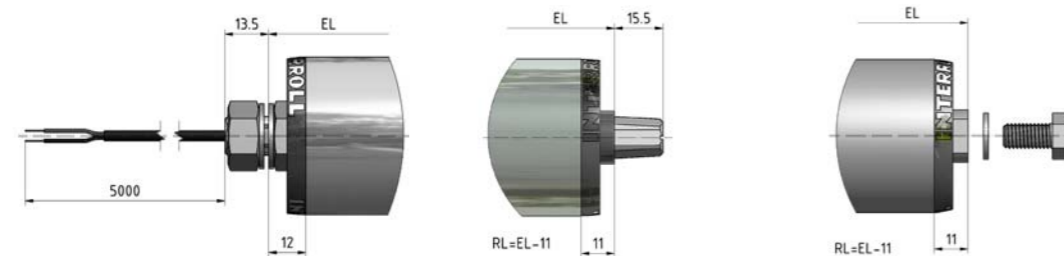

Round belt head

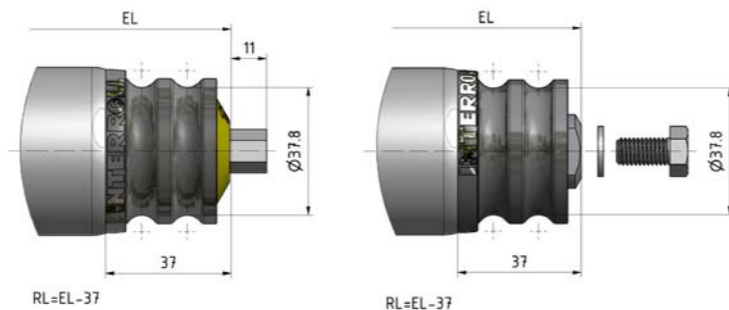

Motor side

Slave side

11 mm hex spring-loaded shaft | Female thread M8
2 grooves

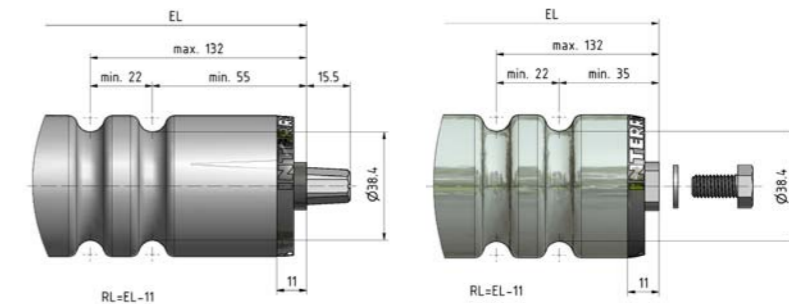

The RollerDrive BT100 is available with 2 core 5 m cable:

Motor cable

Motor cable assignment:

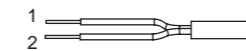

Pin	Colour	Line
1	White	Earth
2	Brown	24 V DC

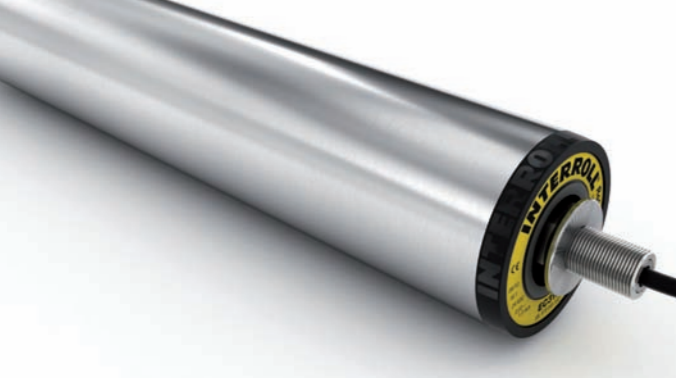

ROLLERDRIVE EC310

RollerDrive with a long service life for a wide range of applications

Product Description

- Internal commutation electronics (brushless motor)
- 9 gear stages
- Constant conveyor speed
- Energy recovery in braking (see also p 199)
- Electronic holding brake (Zero-Motion-Hold) for driving falling conveyors
- Motor cable with 5-pin snap-in plug, without the need for complex screwing

Technical Data

General technical data	
Mechanical power	32 W
Max. noise level	50 dB(A) (application-dependent)
Possible static bearing load	
Slave side: Female thread / Spring-loaded shaft	1100 N
Slave side: PolyVee with female thread / spring-loaded shaft	
Round belt head with female thread / with spring-loaded shaft	350 N
Electrical data	
Rated voltage	24 V DC
Temporarily permissible voltage range	18 to 28 V DC
Idle current	0.4 A
Rated current	2.0 A
Max. start-up current	5.0 A
Permissible voltage undulation	< 3 %
Protection rate	IP54
Dimensions	
Tube diameter / Wall thickness	50 x 1.5 mm; 51 x 2 mm
Max. reference length	1,500 mm
Ambient conditions	
Ambient temperature in operation	0 to +40 °C
Ambient temperature during transport and storage	-30 to +75 °C
Max. air humidity	85 %

Product Selection

The following tables provide an overview of the possible versions.

Gear ratio	Max. conveyor speed	Rated torque	Start-up torque	Zero motion hold
	m/s	Nm	Nm	Nm
9:1	1.75	0.45	1.10	0.36
12:1	1.31	0.61	1.46	0.48
16:1	0.98	0.81	1.95	0.64
20:1	0.79	1.01	2.44	0.80
24:1	0.65	1.21	2.92	0.96
36:1	0.44	1.82	4.38	1.44
48:1	0.33	2.42	5.85	1.92
64:1	0.25	3.23	7.80	2.56
96:1	0.16	4.84	11.69	3.84

Gear stage versions

Tube material	Stainless steel; steel, zinc-plated; steel, chrome-plated; aluminium
Motor shaft	11 mm with hex and thread M12 x 1
Motor shaft material	Stainless steel
Tube sleeve	PVC hose 2 / 5 mm, PU hose 2 mm, rubber coating 2 to 5 mm, tapered tube sleeves
Length of motor cable	0.48 m

Further versions

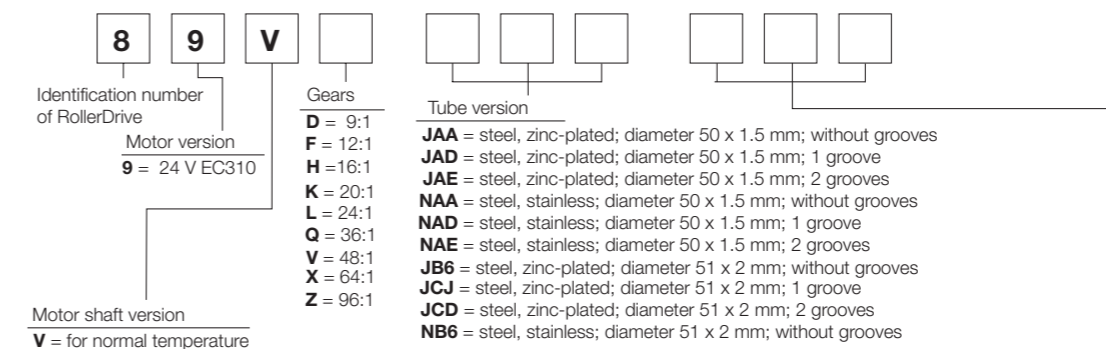

Reference number

Assembly & design on non-cable side

- 6FT = Bearing housing without torque transmission, female thread, uncoated ball bearing, stainless steel fixing material
- 6FN = Bearing housing without torque transmission, female thread, stainless steel ball bearing, stainless steel fixing material
- 8SL = Bearing housing without torque transmission, spring-loaded shaft, uncoated ball bearing, zinc-nickel-coated fixing material
- 5PF = PolyVee head, female thread, uncoated ball bearing, zinc-plated fixing material
- 5PS = PolyVee head, spring-loaded shaft, uncoated ball bearing, stainless steel fixing material
- 5PT = PolyVee head, spring-loaded shaft, stainless steel ball bearing, stainless steel fixing material
- 5RF = Round belt head, female thread, uncoated ball bearing, zinc-plated fixing material
- 5RS = Round belt head, spring-loaded shaft, uncoated ball bearing, stainless steel fixing material
- 6TF = Toothed belt head, female thread, stainless steel ball bearing, stainless steel fixing material
- 6SF = Double sprocket head, female thread, stainless steel ball bearing, stainless steel fixing material

Not all criteria can be combined: please ask about tapered tube designs and tube coatings

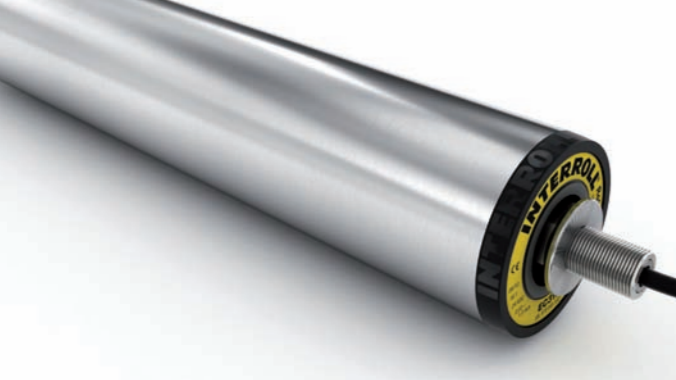

ROLLERDRIVE EC310

RollerDrive with a long service life for a wide range of applications

Dimensions and Connections

Dimensions

The dimensions depend on the shaft and counter bearing selected. The reference length/ordering length RL does not have any reference edges on the conveyor roller and can therefore not be shown. The installation (EL) corresponds to the clearance between the side profiles. All dimensions in mm.

Motor side	Slave side	
11 mm hex M12 x 1	11 mm hex spring-loaded shaft	Female thread M8
	Straight	

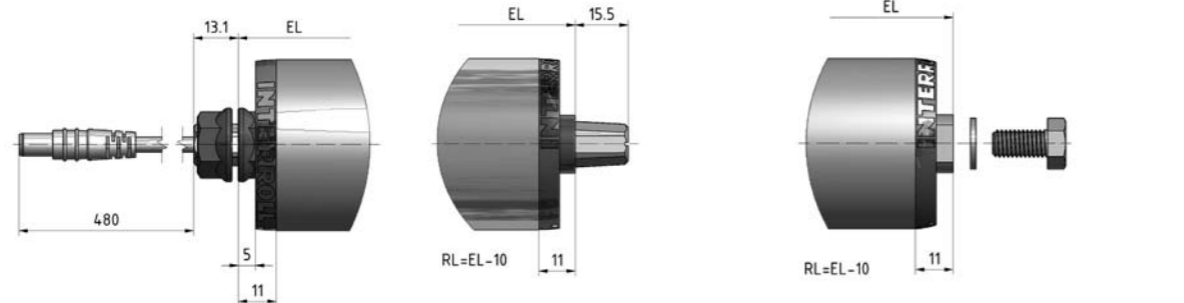

Round belt head

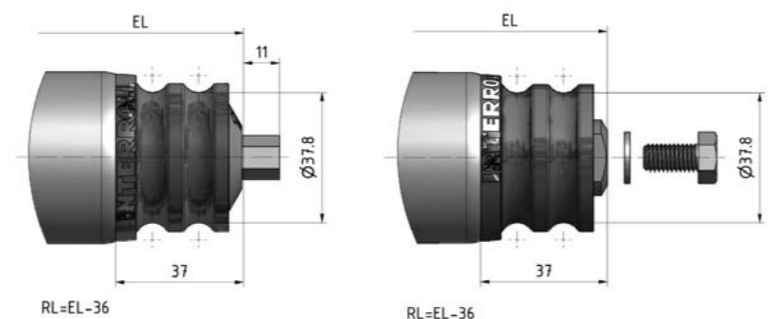

PolyVee Heads

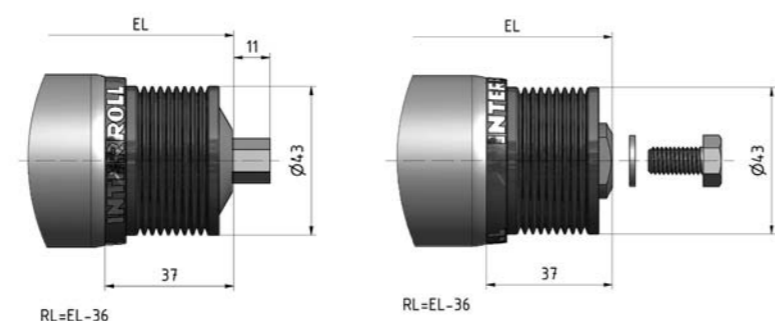

Motor side

Slave side

11 mm hex spring-loaded shaft

Female thread M8

Toothed belt head

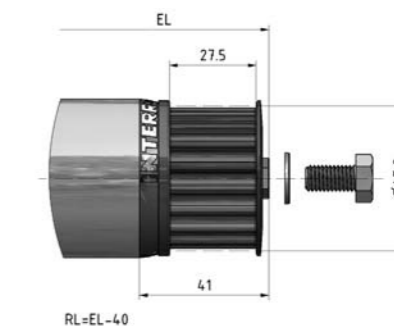

2 grooves

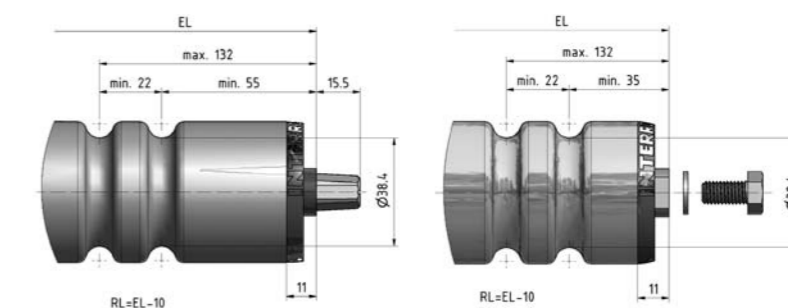

Motor plug assignment:

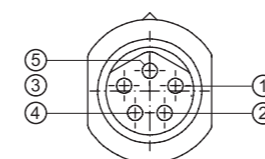

Pin	Colour	Line
1	Brown	+24 V DC
2	White	Direction of rotation
3	Blue	Earth
4	Black	Fault output
5	Grey	Analogue speed input

Motor plug

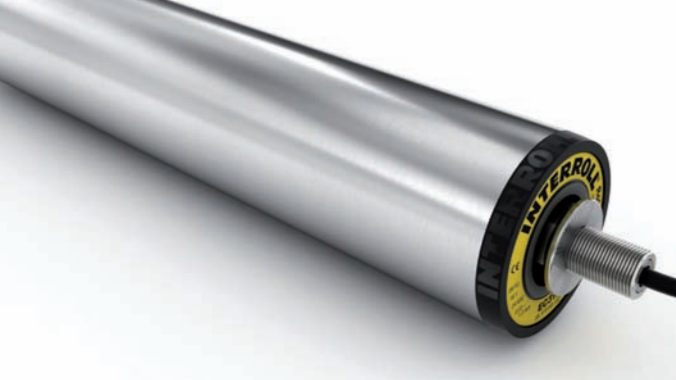

ROLLERDRIVE EC310 FOR REFRIGERATED APPLICATIONS



RollerDrive for refrigerated applications

Product Description

- Internal commutation electronics (brushless motor)
- 4 gear stages
- Constant conveyor speed
- Energy recovery in braking (see also p 199)
- Electronic holding brake
- Motor cable with 5-pin snap-in plug, without the need for complex screwing

Technical Data

General technical data	
Mechanical power	32 W
Max. noise level	50 dB(A) (application-dependent)
Possible static bearing load	
Slave side: Female thread / Spring-loaded shaft	1100 N
Slave side: PolyVee with female thread / spring-loaded shaft	
Round belt head with female thread / with spring-loaded shaft	350 N
Electrical data	
Rated voltage	24 V DC
Temporarily permissible voltage range	18 to 28 V DC
Idle current	0.4 A
Rated current	2.0 A
Max. start-up current	5.0 A
Permissible voltage undulation	< 3%
Protection rate	IP54
Dimensions	
Tube diameter / Wall thickness	50 x 1.5 mm; 51 x 2 mm
Max. reference length	1,500 mm
Ambient conditions	
Ambient temperature in operation	-30 to 0 °C
Ambient temperature during transport and storage	-30 to +75 °C
Max. air humidity	85 %

Product Selection

The following tables provide an overview of the possible versions.

Gear ratio	Max. conveyor speed	Rated torque	Start-up torque	Zero motion hold
	m/s	Nm	Nm	Nm
20:1	0.79	1.01	2.44	0.80
24:1	0.65	1.21	2.92	0.96
36:1	0.44	1.82	4.38	1.44
48:1	0.33	2.42	5.85	1.92

Gear stage versions

Tube material	Stainless steel; steel, zinc-plated; steel, chrome-plated; aluminium
Motor shaft	11 mm with hex and thread M12 x 1
Motor shaft material	Stainless steel
Tube sleeve	PVC hose 2 / 5 mm, PU hose 2 mm, rubber coating 2 to 5 mm, tapered tube sleeves
Length of motor cable	0.48 m

Further versions

8 **9** **Y**

Identification number of RollerDrive

Motor version

9 = 24 V EC310

Motor shaft version

Y= For refrigerated applications

Gears

K = 20:1
L = 24:1
Q = 36:1
V = 48:1

Tube version

JAA = steel, zinc-plated; diameter 50 x 1.5 mm; without grooves

JAD = steel, zinc-plated; diameter 50 x 1.5 mm; 1 groove

JAE = steel, zinc-plated; diameter 50 x 1.5 mm; 2 grooves

NAA = steel, stainless; diameter 50 x 1.5 mm; without grooves

NAD = steel, stainless; diameter 50 x 1.5 mm; 1 groove

NAE = steel, stainless; diameter 50 x 1.5 mm; 2 grooves

JB6 = steel, zinc-plated; diameter 51 x 2 mm; without grooves

JCJ = steel, zinc-plated; diameter 51 x 2 mm; 1 groove

JCD = steel, zinc-plated; diameter 51 x 2 mm; 2 grooves

NB6 = steel, stainless; diameter 51 x 2 mm; without grooves

Reference number

Assembly & design on non-cable side

6FD = Bearing housing without torque transmission, female thread, uncoated ball bearing, stainless steel fixing material

5PA= PolyVee head, female thread, uncoated ball bearing, zinc-plated fixing material

5PB= PolyVee head, spring-loaded shaft, uncoated ball bearing, stainless steel fixing material

5RA= Round belt head, female thread, uncoated ball bearing, zinc-plated fixing material

Not all criteria can be combined: please ask about tapered tube designs and tube coatings

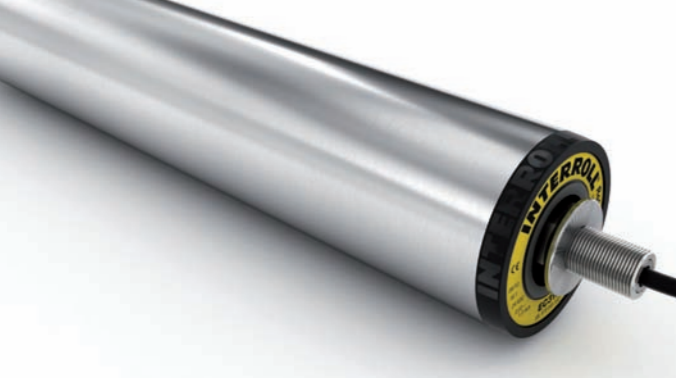

ROLLERDRIVE EC310 FOR REFRIGERATED APPLICATIONS



RollerDrive
EC310 Deepfreeze

RollerDrive for refrigerated applications

Dimensions and Connections

Dimensions

The dimensions depend on the shaft and counter bearing selected. The reference length/ordering length RL does not have any reference edges on the conveyor roller and can therefore not be shown. The installation (EL) corresponds to the clearance between the side profiles. All dimensions in mm.

Motor side	Slave side
11 mm hex M12 x 1	11 mm hex spring-loaded shaft Female thread M8
	Straight

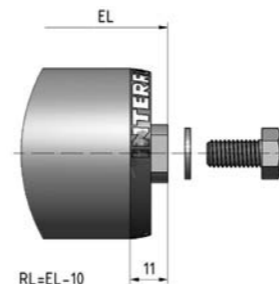
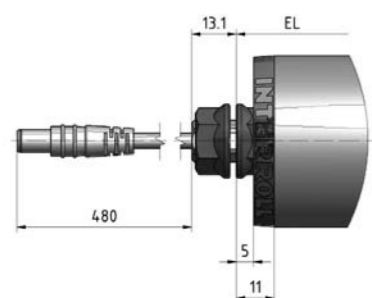

Round belt head

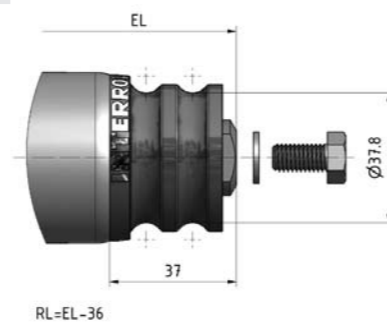

PolyVee Heads

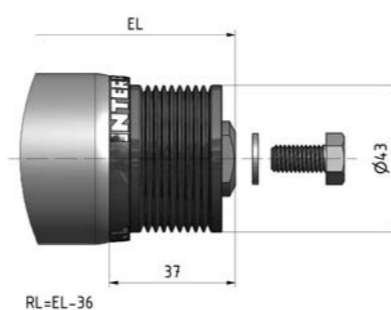
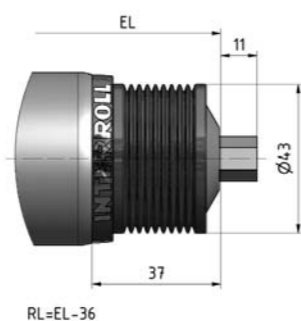

Motor side

Slave side

11 mm hex spring-loaded shaft

Female thread M8

2 grooves

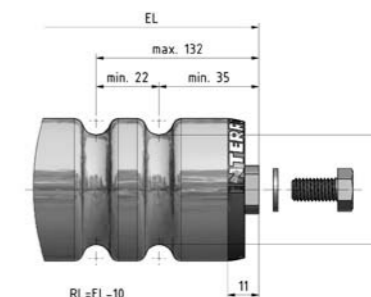

Motor plug assignment:

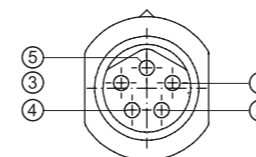

Pin	Colour	Line
1	Brown	+24 V DC
2	White	Direction of rotation
3	Blue	Earth
4	Black	Fault output
5	Grey	Analogue speed input

Motor plug

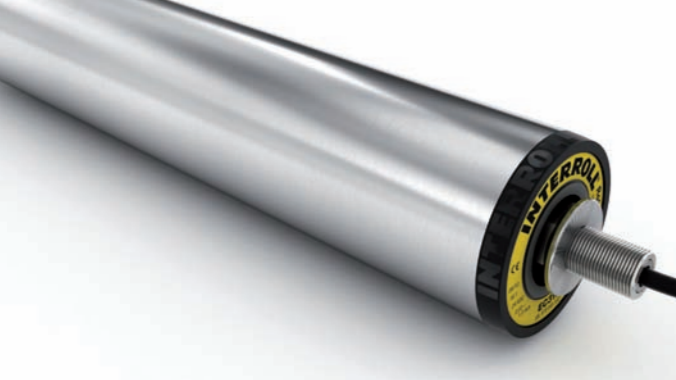

ROLLERDRIVE EC310 IP66



RollerDrive
EC310 IP66

Sealed RollerDrive with a long service life for operation in wet areas

Product Description

- Internal commutation electronics (brushless motor)
- 7 gear stages
- Constant conveyor speed
- Energy recovery in braking (see also p 199)
- Electronic holding brake
- Motor cable with 5-pin snap-in plug, without the need for complex screwing

Technical Data

General technical data	
Mechanical power	32 W
Max. noise level	50 dB(A) (application-dependent)
Possible static bearing load	700 N (Conveyor speed 0,98 m/s)
Slave side: PolyVee female thread/female thread	900 N (Conveyor speed 0,65 m/s) 1100 N (Conveyor speed <= 0,44 m/s)
Electrical data	
Rated voltage	24 V DC
Temporarily permissible voltage range	18 to 28 V DC
Idle current	0.4 A
Rated current	2.0 A
Max. start-up current	5.0 A
Permissible voltage undulation	< 3 %
Protection rate	IP66
Dimensions	
Tube diameter / Wall thickness	50 x 1.5 mm; 51 x 2 mm
Max. reference length	1,500 mm
Ambient conditions	
Ambient temperature in operation	0 to +40 °C
Ambient temperature during transport and storage	-30 to +75 °C
Max. air humidity	85 %, non-condensating

Product Selection

The following tables provide an overview of the possible versions.

Gear ratio	Max. conveyor speed	Rated torque	Start-up torque	Zero motion hold
	m/s	Nm	Nm	Nm
16:1	0.98	0.81	1.95	0.64
20:1	0.79	1.01	2.44	0.80
24:1	0.65	1.21	2.92	0.96
36:1	0.44	1.82	4.38	1.44
48:1	0.33	2.42	5.85	1.92
64:1	0.25	3.23	7.80	2.56
96:1	0.16	4.84	11.69	3.84

Gear stage versions

Tube material	Stainless steel
Motor shaft	11 mm with hex and thread M12 x 1
Motor shaft material	Stainless steel
Tube sleeve	PVC hose 2 / 5 mm, PU hose 2 mm, rubber coating 2 to 5 mm
Length of motor cable	0.48 m

Further versions

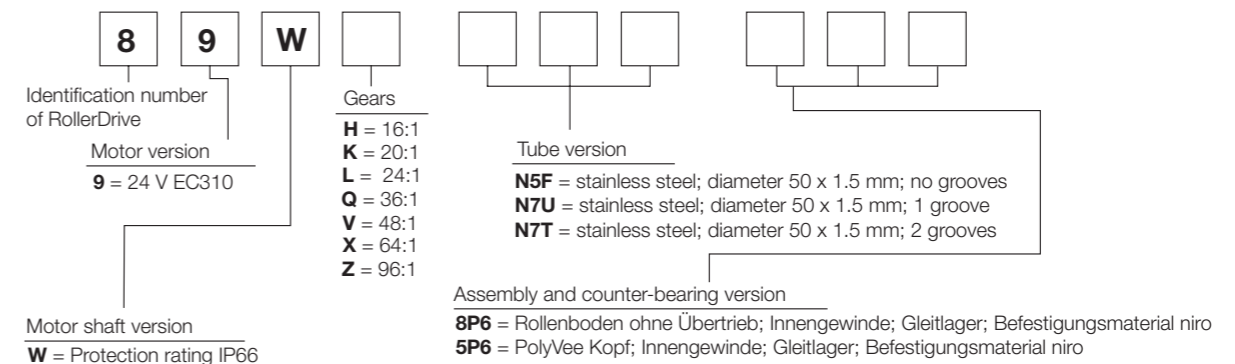

Reference number

Not all criteria can be combined: please ask about tube coatings

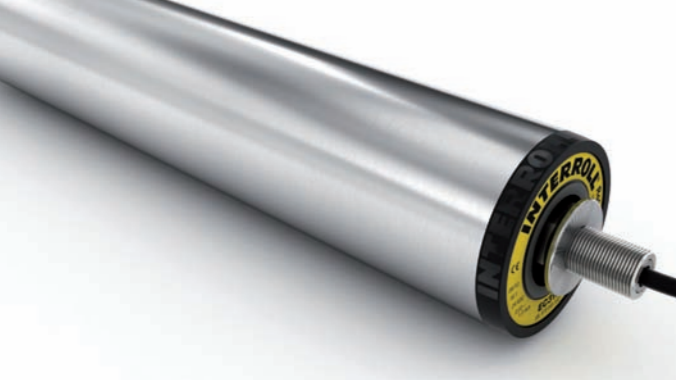

ROLLERDRIVE EC310 IP66



**RollerDrive
EC310 IP66**

Sealed RollerDrive with a long service life for operation in wet areas

Dimensions and Connections

Dimensions The dimensions depend on the shaft and counter bearing selected. The reference length/ordering length RL does not have any reference edges on the conveyor roller and can therefore not be shown. The installation (EL) corresponds to the clearance between the side profiles. All dimensions in mm.

Motor side	Slave side
11 mm hex M12 x 1	Female thread M8 Straight

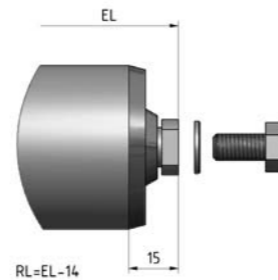
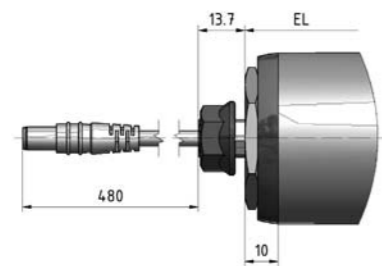

2 grooves

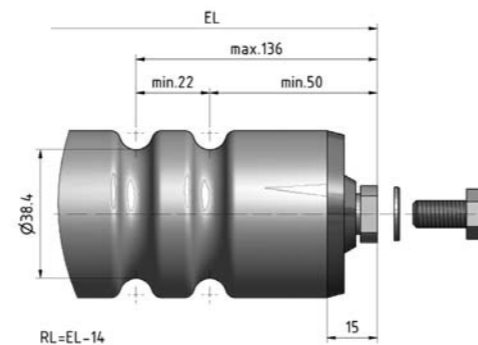

PolyVee Head

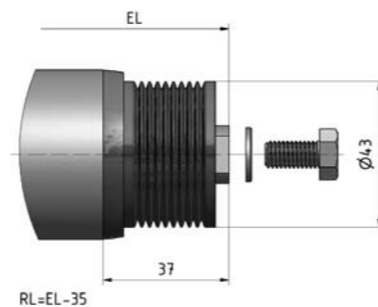

Motor plug assignment:

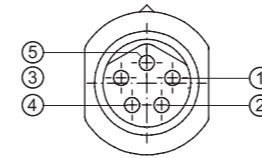

Pin	Colour	Line
1	Brown	+24 V DC
2	White	Direction of rotation
3	Blue	Earth
4	Black	Fault output
5	Grey	Analogue speed input

Motor plug



DRIVECONTROLS OVERVIEW

DriveControl 20

DriveControl 54

ZoneControl

	DriveControl 20	DriveControl 54	ZoneControl
Applications	Motor control	Motor control	Zero pressure accumulation conveyor system
Zero pressure accumulation conveyor system			✓
RollerDrive	EC310 IP66 p 100 EC310 p 92	EC310 IP66 p 100 EC310 for refrigerated applications p 92 EC310 p 92	EC310 IP66 p 100 EC310 p 92
Protection rate	IP20	IP54	IP20
	see page 106	see page 108	see page 110



DRIVECONTROL 20

The all-purpose interface for the RollerDrive EC310

Product Description

Properties The DriveControl 20 is the all-purpose interface for the RollerDrive EC310. The direction of rotation and 15 different speeds can be set using DIP switches. Optically decoupled digital I/O's act as the interface to a higher-order controller. This enables, for instance, the direction of rotation of the 7 different speeds to be set from a PLC. The braking energy of the RollerDrive is fed back into the 24 V grid. The voltage fed back from the RollerDrive EC310 is limited at 30 V by means of the integral brake chopper (voltage-dependently switched load resistance).

- Functions**
- Speed adjustment (15 speeds internally, 7 speeds externally via I/O)
 - Choice of rotational direction
 - Start signal input
 - Rotational direction signal input
 - Fault signal output
 - LED status display

Technical Data

Electrical data	
Rated voltage	24 V DC
Temporarily permissible voltage range	18 to 26 V DC
Permissible voltage undulation	3 %, recommended: < 1 %
Rated current	2.0 A
Max. start-up current	5.0 A
Fuse	present, non-replaceable
Protection rate	IP20
Ambient conditions	
Ambient temperature in operation	0 to +40 °C
Ambient temperature during transport and storage	-20 to +75 °C
Max. temperature change	1 % in 3 h; 2 cycles in compliance with IEC 60068-2-14
Max. air humidity	90 %, non-condensing
Cable cross-sections	
Power Supply	Fine-wired, 1.5 mm ² (AWG 16)
Inputs / Outputs (I/O)	Fine-wired, 0.08 to 0.5 mm ² (AWG 28 to 20)
	Fine-wired, 1.5 mm ² (AWG 16)

The effective current in the application depends on the conveyor weight, conveyor speed and number of cycles.

Reference number: 89RA

Dimensions and Connections

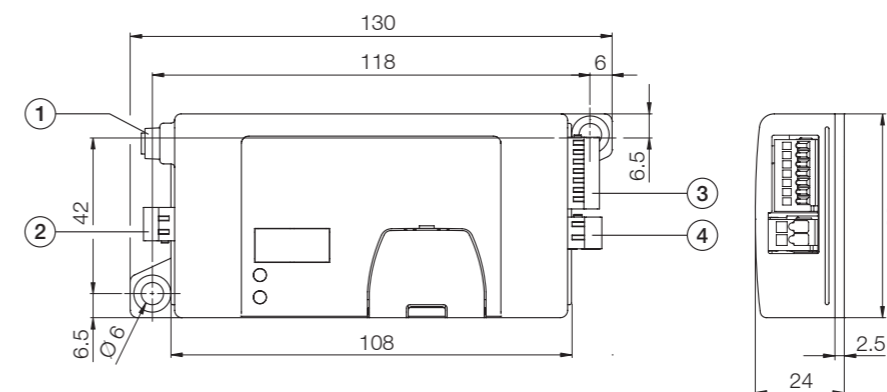

Pos. 1 RollerDrive Connection

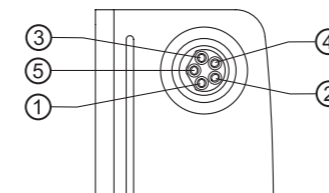

- | | |
|---|-----------------------|
| 1 | +24 V DC |
| 2 | Direction of rotation |
| 3 | Earth |
| 4 | Fault input |
| 5 | Analogue speed output |

Pos. 2 Voltage supply input

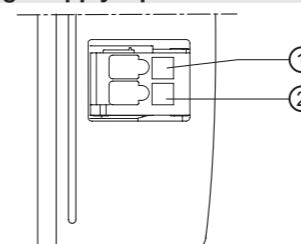

- | | |
|---|----------|
| 1 | +24 V DC |
| 2 | Earth |

Pos. 3 Inputs/Outputs

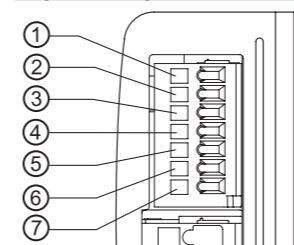

- | | |
|---|-----------------------|
| 1 | Common signal mass |
| 2 | 24 V input |
| 3 | Fault output |
| 4 | Direction of rotation |
| 5 | Speed C |
| 6 | Speed B |
| 7 | Speed A |

Pos. 4 Voltage supply output

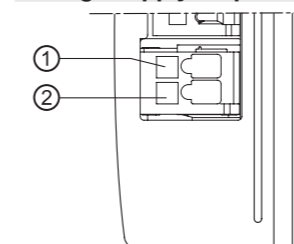

- | | |
|---|----------|
| 1 | Earth |
| 2 | +24 V DC |



DRIVECONTROL 54

The all-purpose interface for the RollerDrive EC310

Product Description

Properties The DriveControl 54 is the all-purpose interface for the RollerDrive EC310. The direction of rotation and 15 different speeds can be set using DIP switches. Optically decoupled digital I/O's act as the interface to a higher-order controller. This enables, for instance, the direction of rotation of the 7 different speeds to be set from a PLC. The braking energy of the RollerDrive is fed back into the 24 V grid. The voltage fed back from the RollerDrive EC310 is limited at 26 V by means of the integral brake chopper (voltage-dependently switched load resistance).

- Functions**
- Speed adjustment (15 speeds internally, 7 speeds externally via I/O)
 - Choice of rotational direction
 - Start signal input
 - Rotational direction signal input
 - Fault signal output
 - LED status display
 - Sealed cable openings

Technical Data

Electrical data	
Rated voltage	24 V DC
Temporarily permissible voltage range	18 to 26 V DC
Permissible voltage undulation	3 %, recommended: < 1 %
Rated current	2.0 A
Max. start-up current	5.0 A
Fuse	present, non-replaceable
Protection rate	IP54
Ambient conditions	
Ambient temperature in operation	-28 to +40 °C
Ambient temperature during transport and storage	-30 to +80 °C
Max. temperature change	1 % in 3 h; 2 cycles in compliance with IEC 60068-2-14
Max. air humidity	90 %, non-condensing
Cable cross-sections	
Power Supply	Fine-wired, 1.5 mm ² (AWG 16)
Inputs / Outputs (I/O)	Fine-wired, 0.08 to 0.5 mm ² (AWG 28 to 20)

The effective current in the application depends on the conveyor weight, conveyor speed and number of cycles.

Reference number: 89RB

Dimensions and Connections

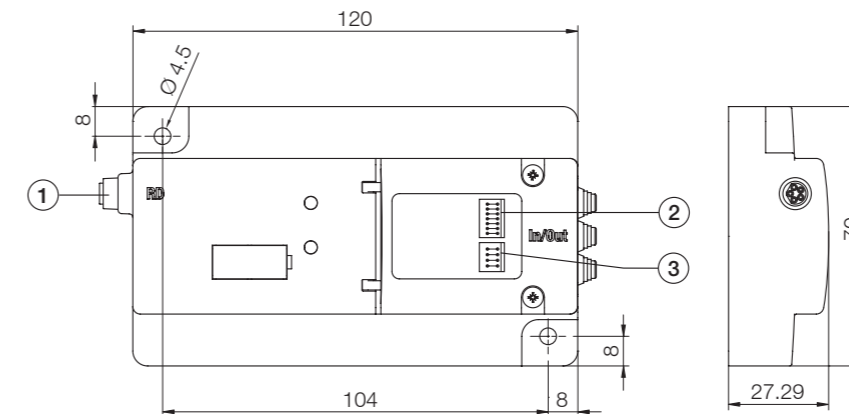

Pos. 1 RollerDrive Connection

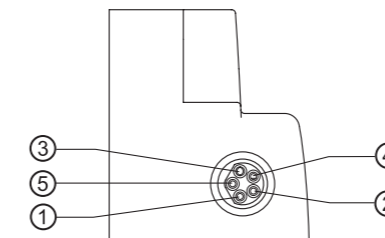

- | | |
|---|-----------------------|
| 1 | +24 V DC |
| 2 | Direction of rotation |
| 3 | Earth |
| 4 | Fault input |
| 5 | Analogue speed output |

Pos. 2 Inputs/Outputs

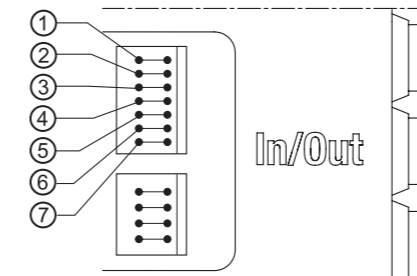

- | | |
|---|-----------------------|
| 1 | Common signal mass |
| 2 | 24 V input |
| 3 | Fault output |
| 4 | Direction of rotation |
| 5 | Speed C |
| 6 | Speed B |
| 7 | Speed A |

Pos. 3 Power Supply

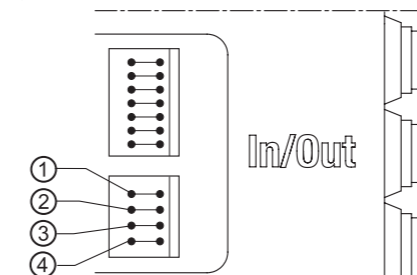

- | | |
|---|----------|
| 1 | Earth |
| 2 | +24 V DC |
| 3 | Earth |
| 4 | +24 V DC |



DriveControl
ZoneControl

ZONECONTROL

The accumulation conveyor logic for RollerDrive EC310

Product Description

- Properties** The ZoneControl is the single zone control for the RollerDrive EC310. The ZoneControl can be used to create stand-alone, zero pressure accumulation conveyors which require no higher-order control. Additional functions and communication to upstream and downstream conveyors can be provided via digital inputs and outputs (I/O's). No DriveControls are needed to set up a conveyor as the ZoneControls include their functions.
- Design information** The I/O's and voltage supply is provided by a simple switching wire.
Communications cable: Conventional Cat-5 cable (IT ethernet cable).
- Configuration** The configuration of the ZoneControl can simply be handled by DIP switches. Two versions of conveyor logic are available: individual or block pull-off.
- Functions**
- Logic for zero pressure accumulation conveying (incl. initialisation)
 - Communication with upstream and downstream zones via peer-to-peer connection
 - Speed adjustment
 - DIP switch (per accumulation zone)
 - External analogue signal (for the entire conveyor system)
 - Adjustment of the RollerDrive's direction of rotation
 - DIP switch
 - External digital signal
 - LED status indicator
 - Zone sensor connection
 - Start sensor connection
 - NPN or PNP switching logic
 - Switching a second RollerDrive, status reading, starting and stopping of individual zones via I/O's
 - Empty running, error signalling of all connected zones via I/O's
 - All signals relate to mass of voltage supply

Technical Data

Electrical data	
Rated voltage	24 V DC
Temporarily permissible voltage range	18 to 26 V DC
Permissible voltage undulation	3 %, recommended: < 1 %
Rated current	2.0 A
Max. start-up current	5.0 A
Fuse	present, non-replaceable
Protection rate	IP20
Ambient conditions	
Ambient temperature in operation	0 to +40 °C
Ambient temperature during transport and storage	-20 to +75 °C
Max. temperature change	1 % in 3 h; 2 cycles in compliance with IEC 60068-2-14
Max. air humidity	90 %, non-condensing
Cable cross-sections	
Power Supply	Fine-wired, 1.5 mm ² (AWG 16)
Inputs / Outputs (I/O)	Fine-wired, 0.08 to 0.5 mm ² (AWG 28 to 20)

The effective current in the application depends on the conveyor weight, conveyor speed and number of cycles.

Reference number: 89RC



ZONECONTROL

The accumulation conveyor logic for RollerDrive EC310

Dimensions and Connections

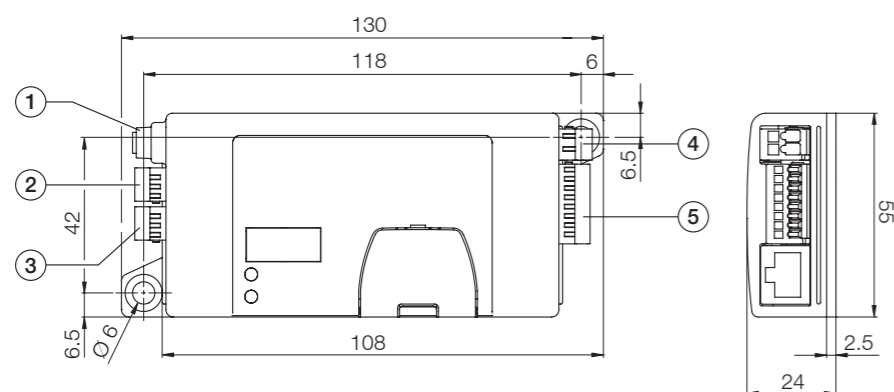

Pos. 1 RollerDrive Connection

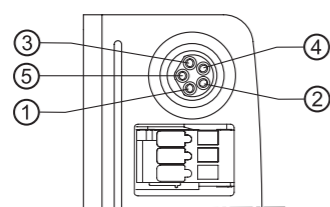

- 1 +24 V DC
- 2 Direction of rotation
- 3 Earth
- 4 Fault input
- 5 Analogue speed output

Pos. 2 Start sensor

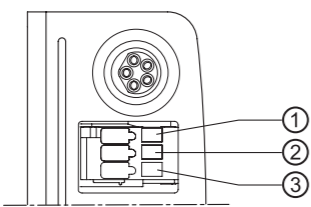

- 1 +24 V DC
- 2 Sensor signal input
- 3 Earth

Pos. 3 Zone sensor

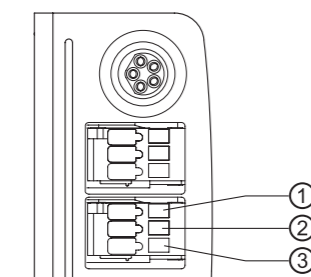

- 1 +24 V DC
- 2 Sensor signal input
- 3 Earth

Pos. 4 Power

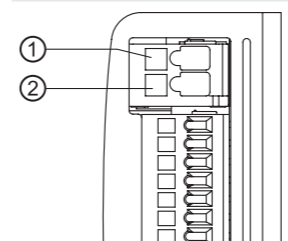

- 1 Earth
- 2 +24 V DC

Pos. 5 Inputs/Outputs

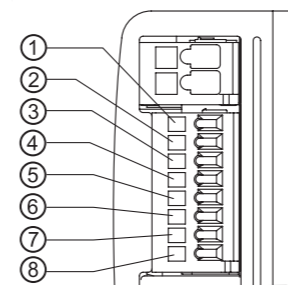

- 1 Start signal for 2nd RollerDrive in zone
- 2 Free travel signal
- 3 Speed (central)
- 4 Direction of rotation (central)
- 5 Fault output
- 6 Zone status
- 7 Zone start
- 8 Zone stop

Construction

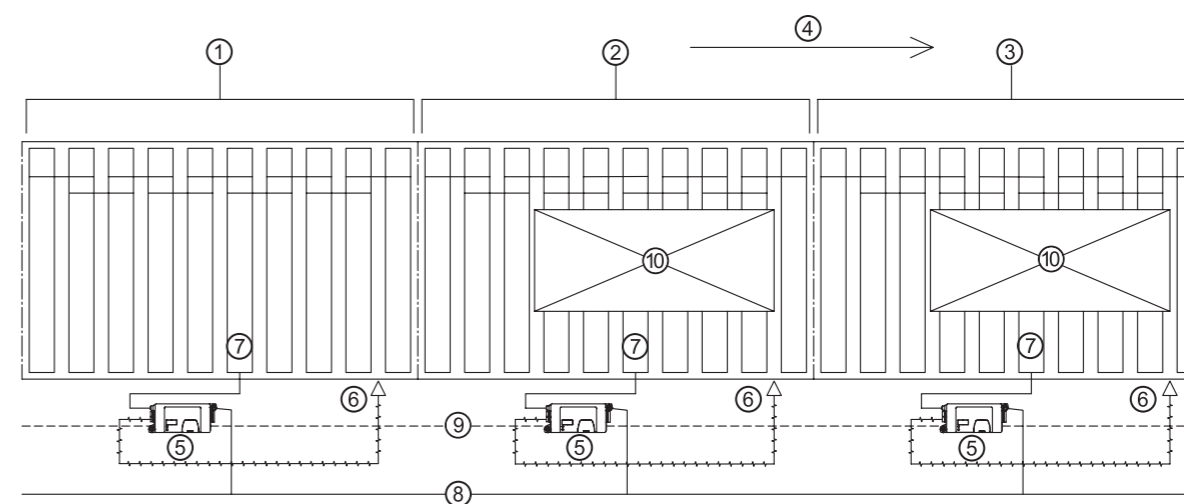

Fig.: Wiring diagram for ZoneControl for 3 conveyor zones

- 1 Zone 1
- 2 Zone 2
- 3 Zone 3
- 4 Conveyor direction
- 5 ZoneControl
- 6 Zone sensor
- 7 RollerDrive
- 8 +24 V DC voltage supply
- 9 Peer-to-peer connection
- 10 Material to be conveyed





SOLUTIONS FOR HEAVY MATERIALS TO BE TRANSPORTED

With this product range, you can set up roller conveyors for heavy materials to be transported, for example for pallets, crates or heavy steel containers from the automotive industry weighing up to 1,500 kg and at conveyor speeds of up to 0.5 m/s. The maximum load capacity of these products is 5,000 N per conveyor roller.

Products for heavy materials to be transported

Conveyor Rollers

The basis of every roller conveyor

p 118



OVERVIEW OF CONVEYOR ROLLERS

	Heavy-duty Conveyor Roller Series 1450	Heavy-duty Conveyor Roller Series 3560	Heavy-duty Conveyor Roller Series 3600	Heavy-duty Conveyor Roller Series 3950
Max. load capacity	5,000 N	3,000 N	3,500 N	5,000 N
Applications	Gravity	Fixed drive	Fixed drive	Fixed drive
Tube diameter	80 / 89 mm	60 mm	80 / 89 mm	80 / 89 mm
Drive concepts				
Gravity	✓			
Chain		✓	✓	✓
Toothed belt			✓	
Material of drive element	–	Steel	Technopolymers	Steel
	see page 120	see page 122	see page 128	see page 132



HEAVY-DUTY CONVEYOR ROLLER SERIES 1450



Conveyor Rollers
Gravity
Series 1450

Universal and stable gravity conveyor roller for heavy loads

Product Description

- Customer benefits**
 - Universal conveyor roller for heavy loads
 - Load capacity up to 5,000 N
 - Silent conveyor roller
 - Precision ball bearing, bearing housing made of polyamide and seal of polypropylene
 - Protects the ball bearing from coarse dirt and water
 - Additional sealing lip in front of sealed precision ball bearing
 - Axial loads are possible
 - Axial forces diverted by ball bearing
 - Gentle lateral pushing of the materials to be conveyed
 - Rounded tube ends
- Applications**
 - In-house conveyor technology
 - Gravity conveyor track for pallets, steel containers etc.
- Properties**
 - Sealed precision ball bearing (6205 2RZ)
 - Form-fit axial fixing of bearing housing, ball bearing and seal
 - Steel bearing housing for use in refrigerated applications
- Associated platform**
 - Platform 1450

Technical Data

General technical data

Max. load capacity	5,000 N
Max. conveyor speed	0.80 m/s
Temperature range	-5 to +40 °C
Temperature range for steel bearing housing	-28 to +80 °C

Materials

Bearing housing	Polyamide
Seal	Polyamide
Ball	6205 2RZ

The dynamic load and the surface load are the assumptions for the load capacity.

Load capacity

Female threaded shaft version

Tube material	Ball bearing	Ø Tube mm	Ø Shaft mm	Max. load capacity in N with an installation length of mm						
				200	1,000	1,200	1,400	1,600	1,800	2,000
Steel, zinc-plated	6205 2RZ	80 x 2	20	5,000	5,000	4,400	3,200	2,440	1,920	1,550
		80 x 3	20	5,000	5,000	5,000	4,630	3,520	2,770	2,240
		89 x 3	20	5,000	5,000	5,000	5,000	4,910	3,860	3,120



HEAVY-DUTY CONVEYOR ROLLER SERIES 1450



Conveyor Rollers
Gravity
Series 1450

Universal and stable gravity conveyor roller for heavy loads

Product Selection

Standards Female threaded shaft version

Material	Ø mm	Ball bearing	Shaft	
			Reference number	Ø 20 mm (M10 x 20)
Steel, zinc-plated	80 x 2.0	6205 2RZ	1.450.JAC.S12	1.450.JAC.S03
	80 x 3.0	6205 2RZ	1.453.J8A.S12	1.453.J8A.S03
	89 x 3.0	6205 2RZ	1.455.J8B.S12	1.455.J8B.S03

Ordering information Please state in addition to the reference number the reference length RL and optionally the dimensions for the tube sleeve.

Ordering example

Example of a reference number: 1.453.J8A.S03 - 490

This reference number is for a Conveyor Roller Series 1450, Ø tube 80 x 3 mm, Ø shaft 20 mm, female threaded shaft and reference length 490 mm. The reference length RL can be found in the table of dimensions for female threaded shafts: $RL = EL - 10$. The axial play of 0.5 mm per side has already been taken into account. The nominal clearance of your conveyor is 500 mm, which also corresponds to the installation length EL, i. e. the reference length is: $500 - 10 = 490$ mm.

RL	Reference length/Ordering length
EL	Installation length
AGL	Total length of shaft

Dimensions for female threaded shaft

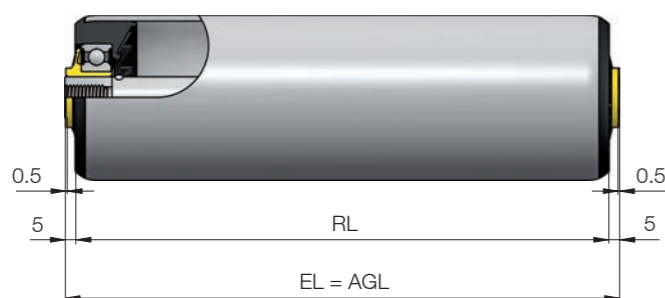

Ø Shaft mm	Thread mm	Ø Tube mm	RL mm
20	M10/12 x 20	80/89	EL - 10

Options

We can offer you the following options in addition to our standard products:

- Flanges
- Tube sleeves for Ø 80 mm
 - Flexible PVC sleeve
 - Rubber coating
- Steel bearing housing for refrigerated applications of -28 °C up to +80 °C



HEAVY-DUTY CONVEYOR ROLLER SERIES 3560



Conveyor Rollers
Fixed drive
Series 3560

Stable fixed drive for small roller pitches

Product Description

- Customer benefits**
 - Stable, fixed drive conveyor roller
 - Welded steel sprockets, steel tube 60 x 3 mm
 - Conveyor reinforced by captive shaft
 - Female threaded shaft Ø 17 mm
 - Small pitches possible
 - Ø 60 mm and tangential drive
 - Gentle lateral pushing of the materials to be conveyed
 - Rounded tube ends
- Applications**
 - In-house driven conveyance of heavy material to be conveyed for which small roller pitches are required
 - Pallets, steel containers without continuous runners
- Properties**
 - Sealed precision ball bearing (6003 2RZ)
 - Steel sprockets, welded to tube
 - Zinc-plated as a component after welding
- Associated platform**
 - Platform 1700

Technical Data

General technical data

Max. load capacity	3,000 N
Max. conveyor speed	1.2 m/s
Temperature range	-5 to +40 °C

Materials

Bearing housing	Polyamide
Drive head	Steel
Seal	Polyamide
Ball bearing	Steel 6003 2RZ

The load capacity depends on the length of the roller.

Load capacity

Female threaded shaft version

Tube material	Ø Tube mm	Ø Shaft mm	Max. load capacity in N with an installation length of mm					
			200	900	1,000	1,100	1,300	1,500
Steel, zinc-plated	60 x 3	17	3,000	3,000	2,910	2,160	1,290	830



HEAVY-DUTY CONVEYOR ROLLER SERIES 3560



Conveyor Rollers
Fixed drive
Series 3560

Stable fixed drive for small roller pitches

Product Selection

Standards Female threaded shaft version

Material	Ø mm	Torque transmission	Ball bearing	Shaft Reference number Ø 17 mm (M12 x 20)
Steel, zinc-plated	60 x 3.0	Steel sprocket 5/8", Z = 13	6003 2RZ	3.56W.JDC.RAJ
		2 steel sprockets 5/8", Z = 13	6003 2RZ	3.56W.JDB.RAL

Ordering information Please state in addition to the reference number the reference length RL and optionally the dimensions for the tube sleeve.

Ordering example

Example of a reference number: 3.56A.JDC.RAJ - 464

This reference number is for a Conveyor Roller Series 3560, Ø tube 60 mm, steel sprocket 5/8", Z = 13, Ø shaft 17 mm, female threaded shaft and reference length 464 mm. The reference length RL can be found on the dimensioned drawing: $RL = EL - 36$. The axial play of the sides of 1 mm and 0.5 mm has already been taken into account. The nominal clearance of your conveyor is 500 mm, which also corresponds to the installation length EL, i. e. the reference length is: $500 - 36 = 464$ mm.

Dimensions	RL	Reference length/Ordering length*
	EL	Installation length
	AGL	Total length of shaft
	F	Length of the bearing assembly, including axial play

*The reference length/ordering length RL does not have any reference edges on the conveyor roller and can therefore not be shown.

Dimensions for steel sprocket

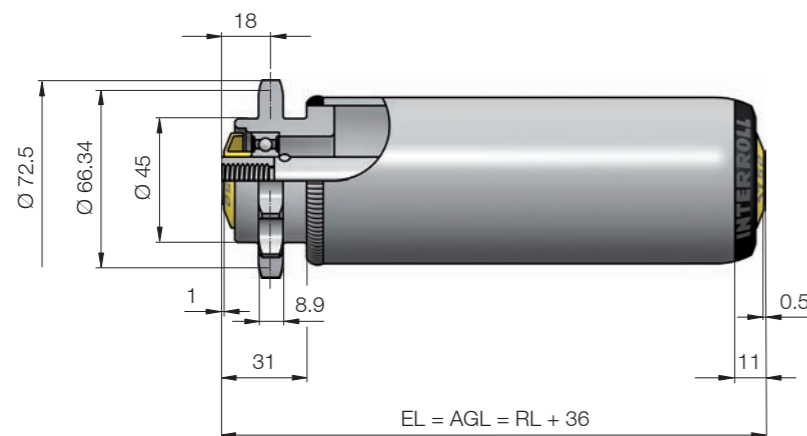

Dimensions for 2 steel sprockets

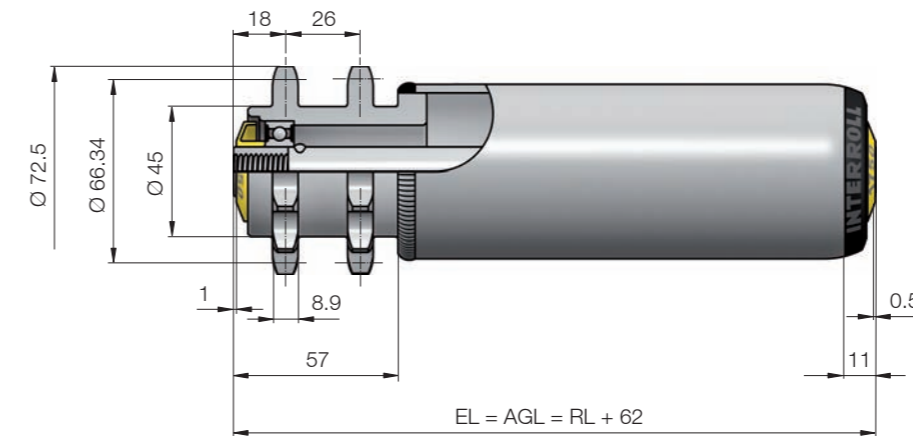

Options

We can offer you the following options in addition to our standard products:

- Flanges
- Tube sleeves
 - Flexible PVC sleeve
 - Rubber coating



HEAVY-DUTY CONVEYOR ROLLER SERIES 3600



Conveyor Rollers
Fixed drive
Series 3600

Sturdy, reliable, cost-effective standard solution

Product Description

- Customer benefits**
 - Exceptionally low-noise operation
 - Drive heads made of fibreglass-reinforced, viscoplastic polyamide
 - Drive elements secured against twisting and axial movement against the tube
 - Form-fit join with notches at the tube ends
 - Comprehensive drive versions
 - Roller-to-roller and tangential chain drive, toothed belt drive
 - Gentle lateral pushing of the materials to be conveyed
 - Rounded tube ends
- Applications**
 - In-house driven conveyance of heavy materials to be conveyed
 - Pallets, steel containers etc.
- Properties**
 - Sealed precision ball bearing (6204 2RZ, 6205 2RZ)
- Associated platform**
 - Platform 1450

Technical Data

General technical data	
Max. load capacity	3,500 N
Max. conveyor speed	0.50 m/s
Temperature range	0 to +40 °C
Materials	
Bearing housing	Polyamide
Drive head	Polyamide
Seal	Polyamide
Ball bearing	Steel 6204 2RZ, 6205 2RZ

Load capacity The dynamic load and the surface load are the assumptions for the load capacity.

Female threaded shaft version

Ø Tube mm	Torque transmission	Max. load capacity in N with an installation length of mm							
		200	400	600	800	1,000	1,200	1,400	1,600
80 x 3	Polymer sprocket	3,500	3,500	3,500	3,500	3,500	3,500	3,500	3,500
89 x 3									
80 x 3	2 polymer sprockets or toothed belt head	3,500	3,500	3,150	3,000	2,930	2,880	2,850	2,820
89 x 3									

Product Selection

Female threaded shaft version

Tube			Ball bearing	Shaft	
Material	Ø mm	Torque transmission		Reference number	
				Ø 20 mm (M12 x 20) without flange	Ø 20 mm (M12 x 20) with flange
Steel, zinc-plated	80 x 3.0	Toothed belt head	6205 2RZ 6204 2RZ	3.6AZ.J8E.S38	3.6AZ.J8D.S38
		Polymer sprocket 5/8", Z = 18	6205 2RZ 6204 2RZ	3.6AJ.J8E.S42	3.6AJ.J8D.S42
		Polymer sprocket 5/8", Z = 15	6205 2RZ 6204 2RZ	3.6AC.J8E.S42	3.6AC.J8D.S42
		2 Polymer sprockets 5/8", Z = 18	6205 2RZ 6204 2RZ	3.6AK.J8E.S38	3.6AK.J8D.S38
		2 polymer sprockets 5/8", Z = 15	6205 2RZ 6204 2RZ	3.6AD.J8E.S38	3.6AD.J8D.S38
	89 x 3.0	Toothed belt head	6205 2RZ 6204 2RZ	3.6AX.J90.S38	3.6AX.J8C.S38
		Polymer sprocket 5/8", Z = 18	6205 2RZ 6204 2RZ	3.6AL.J90.S42	3.6AL.J8C.S42
		Polymer sprocket 5/8", Z = 15	6205 2RZ 6204 2RZ	3.6AE.J90.S42	3.6AE.J8C.S42
		2 polymer sprockets 5/8", Z = 18	6205 2RZ 6204 2RZ	3.6AM.J90.S38	3.6AM.J8C.S38
		2 polymer sprockets 5/8", Z = 15	6205 2RZ 6204 2RZ	3.6AF.J90.S38	3.6AF.J8C.S38

Standards

On request, we can offer you further options in addition to our standard products (cf. the following double page).

Example for a reference number: 3.6AC.J8E.S42 - 464

This reference number is for a Conveyor Roller Series 3600, steel, zinc-plated, Ø tube 80 mm, polymer sprocket 5/8", Z = 15, Ø shaft 20 mm, female threaded shaft without flange and reference length 464 mm. The reference length RL can be found on the dimensioned drawing: $RL = EL - 36$. The axial play of 0.5 mm per side has already been taken into account. The nominal clearance of your conveyor is 500 mm, which also corresponds to the installation length EL, i. e. the reference length is: $500 - 36 = 464$ mm.

Order example



HEAVY-DUTY CONVEYOR ROLLER SERIES 3600



Conveyor Rollers
Fixed drive
Series 3600

Sturdy, reliable, cost-effective standard solution

Dimensions

RL	Reference length/Ordering length*
EL	Installation length
AGL	Total length of shaft

Dimensions for polymer sprocket 5/8", without flange

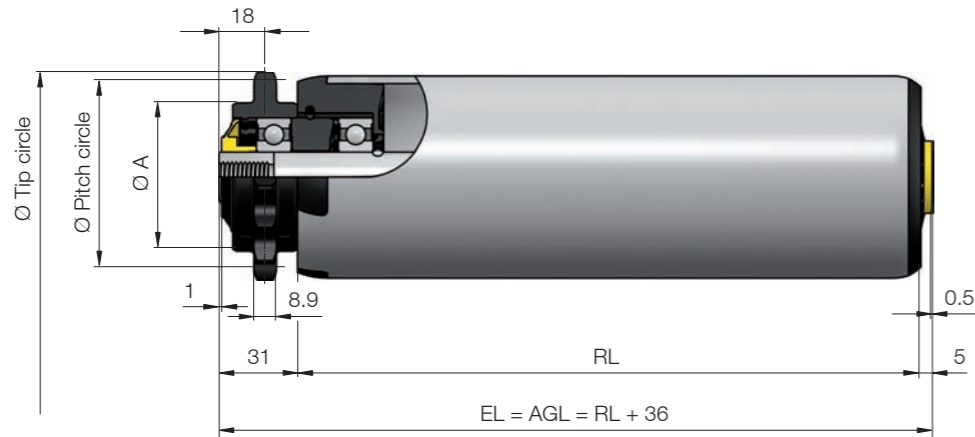

Number of teeth	Ø Tip circle mm	Ø Pitch circle mm	Ø A mm
15	83	76.36	59
18	98	91.42	66

Dimensions for 2 polymer sprockets 5/8", without flange

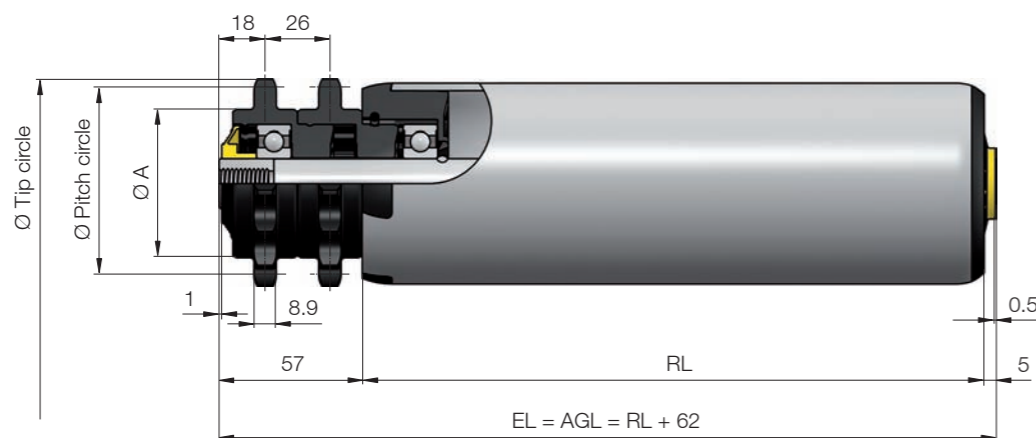

Number of teeth	Ø Tip circle mm	Ø Pitch circle mm	Ø A mm
15	83	76.36	59
18	98	91.42	66

Dimensions for toothed belt head without flange

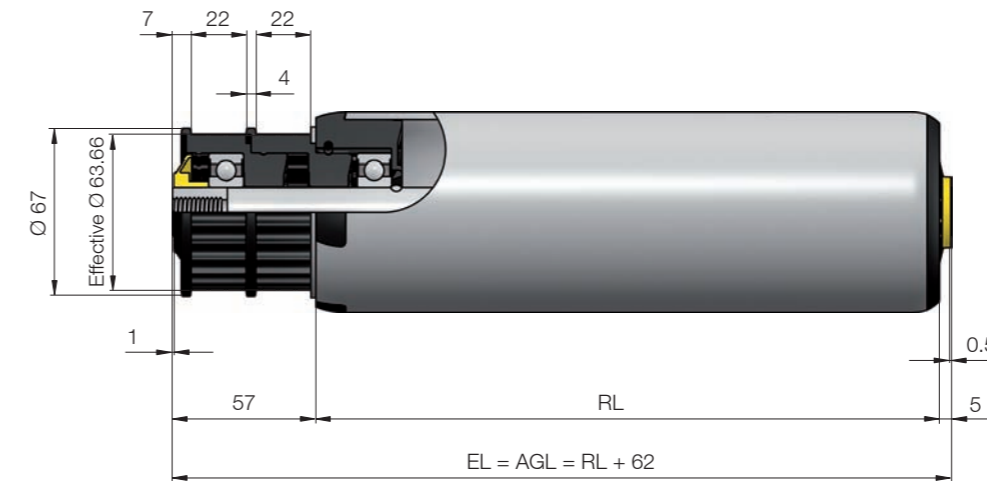

Dimensions for flange

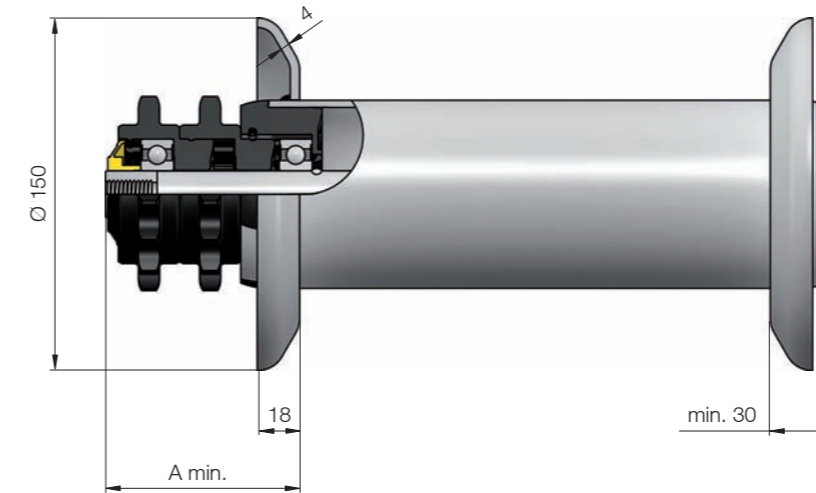

Drive	Pitch A of flange mm
Sprocket	Min. 56
2 sprockets	Min. 82
Toothed belt	Min. 82

Options

We can offer you the following options in addition to our standard products:

- Steel tube, zinc-plated Ø 80 x 2 mm

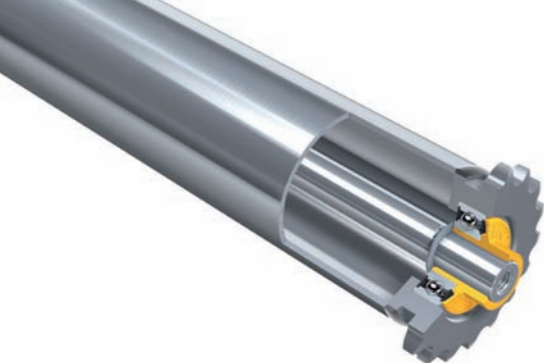

HEAVY-DUTY CONVEYOR ROLLER SERIES 3950



Conveyor Rollers
Fixed drive
Series 3950

The most stable fixed drive conveyor roller for heavy loads

Product Description

- Customer benefits**
 - Particularly sturdy, stable, fixed drive conveyor roller
 - Welded steel sprockets
 - Compatible with Fixed Drive Conveyor Roller Series 3600
 - Identical sprocket dimensions
 - Comprehensive drive versions
 - Roller-to-roller and tangential chain drive
 - Gentle lateral pushing of the materials to be conveyed
 - Rounded tube ends
- Applications**
 - In-house driven conveyance of heavy materials to be conveyed
 - Pallets, steel containers etc.
- Properties**
 - Sealed precision ball bearing (6205 2RZ)
 - Steel sprockets, welded to tube
 - Zinc-plated as a component after welding
- Associated platform**
 - Platform 1450

Technical Data

General technical data	
Max. load capacity	5,000 N
Max. conveyor speed	0.5 m/s
Temperature range	0 to +40 °C
Materials	
Bearing housing	Polyamide
Drive head	Steel
Seal	Polyamide
Ball bearing	Steel 6205 2RZ

Load capacity The dynamic load and the surface load are the assumptions for the load capacity.

Female threaded shaft version

Ø Tube mm	Torque transmission	Max. load capacity in N with an installation length of mm								
		200	400	600	800	1,000	1,200	1,400	1,600	
80 x 3	1 & 2 steel sprockets	5,000	5,000	5,000	5,000	5,000	5,000	4,740	3,600	
89 x 3	1 & 2 steel sprockets	5,000	5,000	5,000	5,000	5,000	5,000	5,000	5,000	

Product Selection

Female threaded shaft version

Tube			Ball bearing	Shaft	
Material	Ø mm	Torque transmission		Reference number	
				Ø 20 mm (M12 x 20) without flange	Ø 20 mm (M12 x 20) with flange
Steel, zinc-plated	80 x 3.0	Steel sprocket 5/8", Z = 18	6205 2RZ	3.951.JJC.S9F	3.951.JJD.S9F
		Steel sprocket 5/8", Z = 15	6205 2RZ	3.951.JJP.S9F	3.951.JJ1.S9F
		2 steel sprockets 5/8", Z = 18	6205 2RZ	3.951.JKC.S9E	3.951.JKD.S9E
	89 x 3.0	2 steel sprockets 5/8", Z = 15	6205 2RZ	3.951.JKW.S9E	3.951.JK1.S9E
		Steel sprocket 5/8", Z = 18	6205 2RZ	3.952.JJE.S9F	3.952.JJF.S9F
		Steel sprocket 5/8", Z = 15	6205 2RZ	3.952.JJY.S9F	3.952.JJ2.S9F
		2 steel sprockets 5/8", Z = 18	6205 2RZ	3.952.JKE.S9E	3.952.JKF.S9E
		2 steel sprockets 5/8", Z = 15	6205 2RZ	3.952.JKY.S9E	3.952.JK2.S9E

On request, we can offer you further options in addition to our standard products (cf. the following double page).

Example of a reference number: 3.951.JJP.S9F - 464

This reference number is for a Conveyor Roller Series 3950, steel, zinc-plated, Ø tube 80 mm, steel sprocket 5/8", Z = 15, Ø shaft 20 mm, female threaded shaft without flange and reference length 464 mm. The reference length RL can be found on the dimensioned drawing: RL = EL - 36. The axial play of 0.5 mm per side has already been taken into account. The nominal clearance of your conveyor is 500 mm, which also corresponds to the installation length EL, i. e. the reference length is: 500 - 36 = 464 mm.

Standards

Ordering example



HEAVY-DUTY CONVEYOR ROLLER SERIES 3950



Conveyor Rollers
Fixed drive
Series 3950

The most stable fixed drive conveyor roller for heavy loads

Dimensions

RL	Reference length/Ordering length
EL	Installation length
AGL	Total length of shaft

Dimensions for steel sprocket 5/8", without flange

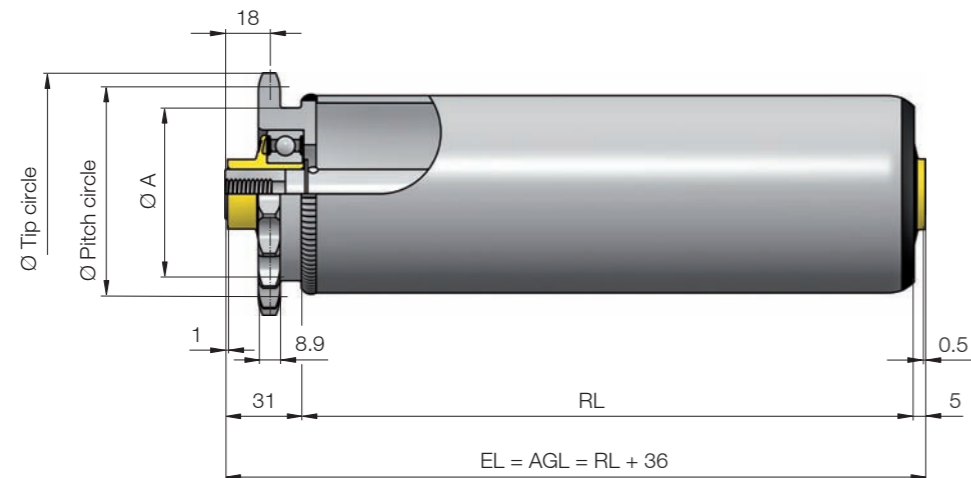

Number of teeth	Ø Tip circle mm	Ø Pitch circle mm	Ø A mm
15	83	76.36	60
18	98	91.42	70

Dimensions for 2 steel sprockets 5/8", without flange

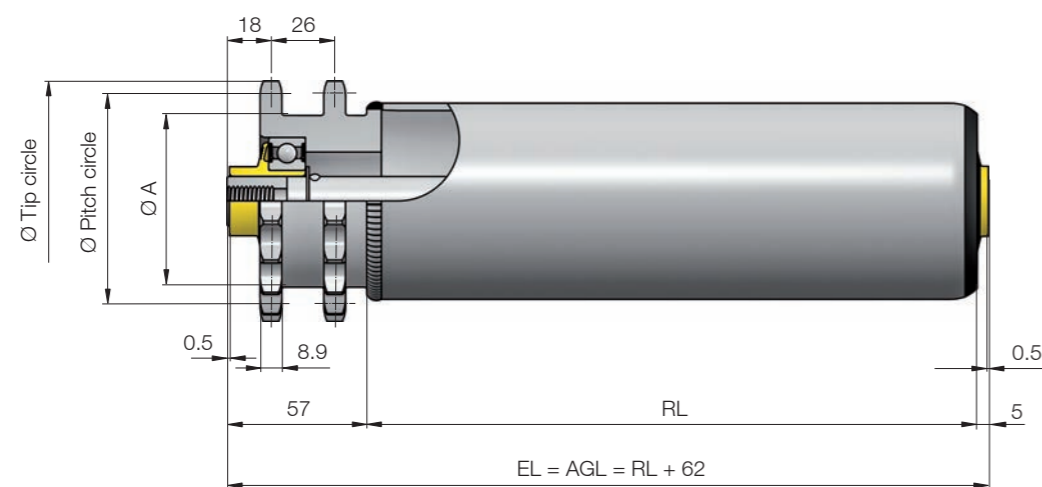

Number of teeth	Ø Tip circle mm	Ø Pitch circle mm	Ø A mm
15	83	76.36	60
18	98	91.42	70

Dimensions for flange

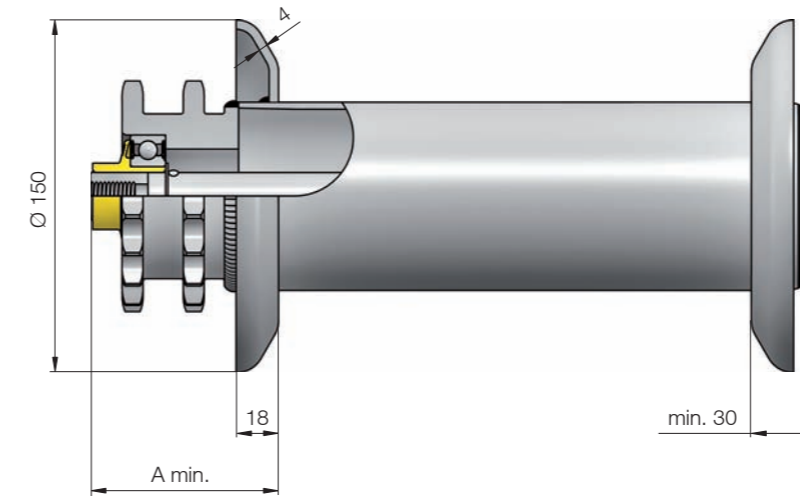

Drive	Pitch A of flange mm
Sprocket	Min. 54
2 sprockets	Min. 80

Options

We can offer you the following options in addition to our standard products:

- Uncoated steel drive head with welded zinc-plated steel tube

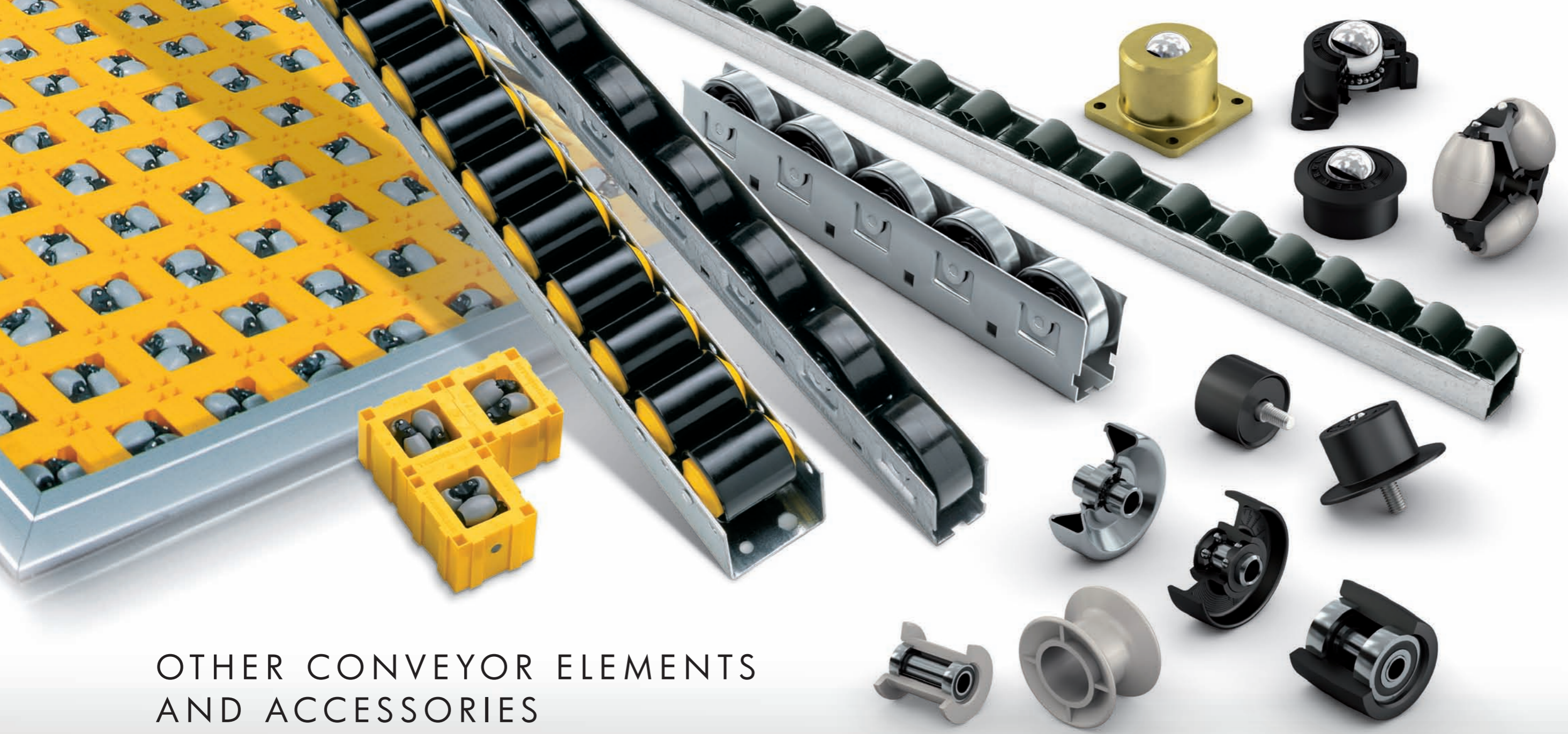

OTHER CONVEYOR ELEMENTS AND ACCESSORIES

Pressure Rollers	Series 2600	For flat belts	p 138
Ball Transfer Units	Series 5500	Load capacity up to 500 N, polymer housing	p 140
	Series 5000	Load capacity up to 20,000 N, steel housing	p 144
Conveyor Wheels	Series 2130	Polymer conveyor wheels Ø 48 mm	p 148
	Series 2370	Polymer conveyor wheels Ø 38 mm	p 150
	Series 2200	Steel conveyor wheels Ø 48 mm	p 152
	OmniWheels	Series 2500	Omniwheels Ø 48 mm and Ø 80 mm
Roller Tracks	Series 2800	Omnimat module 48 mm	p 156
	Series BU 40	Push conveyor tracks, lightweight and medium-heavy containers	p 158
	Series BU 50	Push conveyor tracks, medium-heavy and heavy pallets	p 160
Conveyor Roller Accessories	Series Floway	For order picking shelves and roller carpets	p 162
	PolyVee Belts	Drive belts for Series 3500 and RollerDrive	p 164
RollerDrive Accessories	Flanges	Axial guides for lightweight and medium-heavy containers	p 165
	Variable Shaft Projection	± Shaft projections of standard shafts	p 166
	Shaft adapter	Polymer shaft adapters for noise optimisation	p 167
	Antistatic Element	Brass ball for conducting away electrical energy	p 167
RollerDrive Accessories	Cables for Z-Card		p 168
	Extension Cable		p 169



PRESSURE ROLLERS 2600

For flat belts and round belts

Product Description

- Customer benefits**
 - Ball bearing supported with distance tube
 - For fixed screws
 - Alternative stainless steel version
 - Corrosion-proof
 - Tapered bearing surface to the belt guide
 - Self-centring function
- Applications**
 - Belt pressure roller for flat belt drives
 - Suitable for 20 - 30 mm wide flat belts
 - Floating fixing on the profile
- Properties**
 - Precision ball bearing 6000 2RZ, alternatively in stainless steel and 688 2RZ
 - Slide bearing for round belt wheels K 212 made of polyamide

Product Selection

Drive medium	Bearing design	Flange	Material	Colour	Max. load capacity N	Max. conveyor speed m/s	Reference number
Flat belt	6000 2Z	✓	Polyamide	Black	2,500	2.5	2601
	6000 2Z stainless steel	✓	Polyamide	White	2,500	2.5	2606
	6000 2Z		Polyamide	Black	2,500	2.5	2611
	688 2Z stainless steel	✓	Polyoxy-methylene	Grey	2,000	2.5	2610
Round belt	Slide bearing		Polyamide	Grey	1,000	1,2	K 212

Dimensions

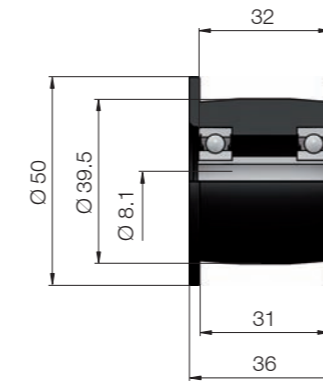

Fig.: Dimensions for 2601 / 2606

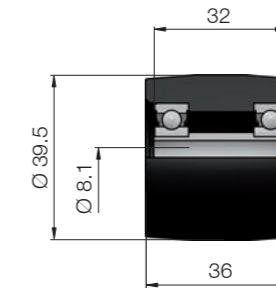

Fig.: Dimensions for 2611

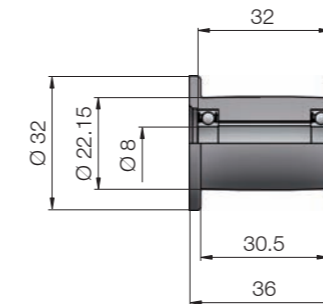

Fig.: Dimensions for 2610

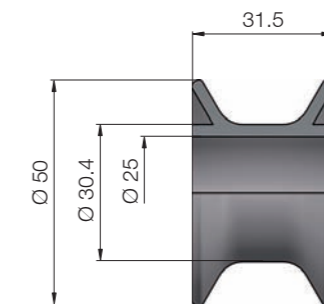

Fig.: Dimensions for K 212



BALL TRANSFER UNITS 5500

Load capacity up to 500 N, polymer housing

Product Description

- Customer benefits**
 - Conveyance possible in every direction
 - Simple construction of intersections and switchblades
 - Easy running balls
 - Stainless steel version (optional)
 - Polymer balls
 - No damage to critical surfaces
- Applications**
 - Alignment of medium-heavy plates, containers with smooth surfaces
 - Pushing of steel or wooden plates
- Properties**
 - The support balls circulate under the main ball in operation so that the material to be conveyed is constantly supported
 - Housing made of polyamide
 - Bearing set for support balls made of hardened steel
 - Protection against dust and spray water by felt seal for steel ball
- Design information**
 - The load capacity of the ball rollers is best used if the balls have exactly the same level

Product Selection

Fixing	Ø Ball mm	Material	Max. load capacity N	Weight g	Reference number
Base flange	25.4	Steel	500	109	5500
		Steel, stainless steel	500	109	5505
		Polymer	200	51	5520
Head flange	25.4	Steel	500	109	5501
		Steel, stainless steel	500	109	5506
		Polymer	200	51	5521
Threaded pin	25.4	Steel	500	117	5504
		Steel, stainless steel	500	117	5509
		Polymer	200	59	5512
Top flange	25.4	Steel	500	107	5503
		Steel, stainless steel	500	107	5508
		Polymer	200	41	5522



Other Conveying
Elements
**Ball Transfer
Units**

BALL TRANSFER UNITS 5500

Load capacity up to 500 N, polymer housing

Dimensions

Dimensions with
base flange

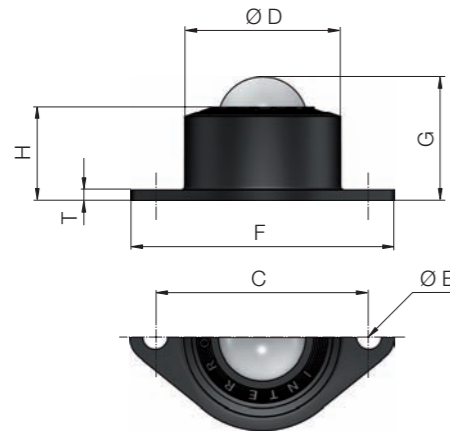

Ø D mm	Ø E mm	C mm	F mm	G mm	H mm	T mm
44.0 - 0.2	7	60	74 / 52	35	26	3

Dimensions
with top flange

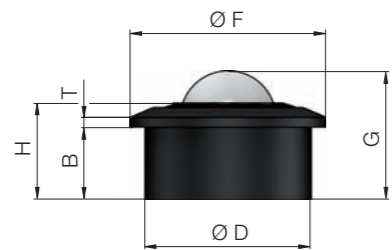

Ø D mm	Ø F mm	B mm	G mm	H mm	T mm
44.0 - 0.2	52	19.5	35	26	3

Dimensions with
threaded pin

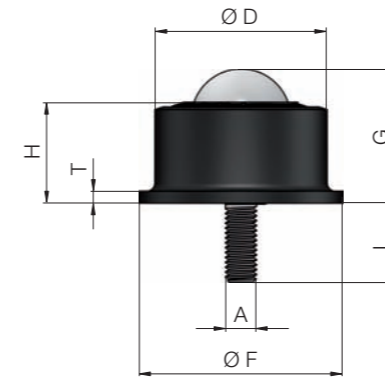

Ø D mm	Ø F mm	A mm	G mm	H mm	L mm	T mm
44.0 - 0.2	52	M8	35	26	22	3

Dimensions
with head flange

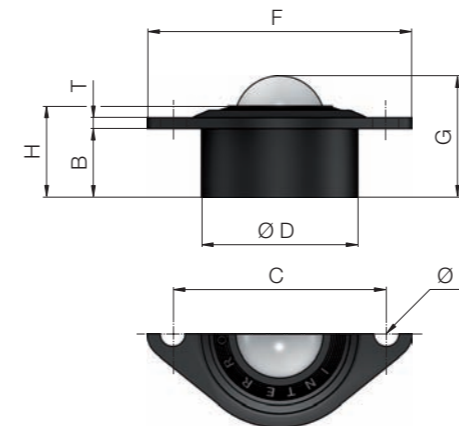

Ø D mm	Ø E mm	B mm	C mm	F mm	G mm	H mm	T mm
44.0 - 0.2	7	19.5	60	74 / 52	35	26	3

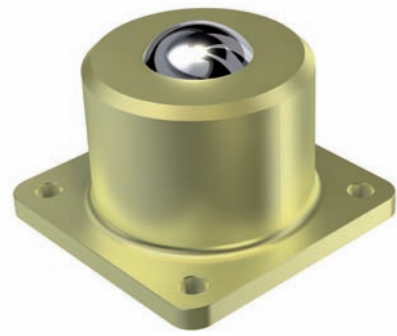

STEEL BALL TRANSFER UNITS 5000

Load capacity up to 20,000 N, steel housing



Other Conveying
Elements
**Ball Transfer
Units**

Product Description

- Customer benefits**
 - Conveyance possible in every direction
 - Simple construction of intersections and switchblades
 - Easy running balls
- Applications**
 - Alignment of medium-heavy and heavy plates, containers with smooth surfaces
 - Pushing of steel or wooden plates
 - Installation upside down is possible
- Properties**
 - The support balls circulate under the main ball in operation so that the material to be conveyed is constantly supported
 - The balls rotate on a number of small circulating balls, which in turn rotate on a hardened mushroom-shaped steel table
- Design information**
 - The load capacity of the ball rollers is best used if the balls have exactly the same level

Product Selection

Fixing	Ø Ball mm	Material	Max. load capacity N	Weight g	Reference number
Base flange	12.7	Steel	360	78	5019
	25.4		1,820	480	5020
	25.4		3,200	797	5021
	38.1		10,000	1,284	5022
	50.8		20,000	5,556	5023
Head flange	12.7	Steel	360	78	5024
	25.4		1,820	432	5025
	25.4		3,200	802	5026
	38.1		10,000	1,284	5027
	50.8		20,000	5,844	5028
Threaded pin	12.7	Steel	360	43	5014
	25.4		1,820	480	5015
	25.4		3,200	598	5016
	38.1		10,000	1,198	5017
	50.8		20,000	5,500	5018

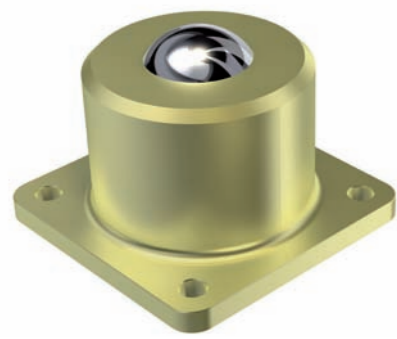

Other Conveying
Elements
**Ball Transfer
Units**

STEEL BALL TRANSFER UNITS 5000

Load capacity up to 20,000 N, steel housing

Dimensions

Dimensions with
base flange

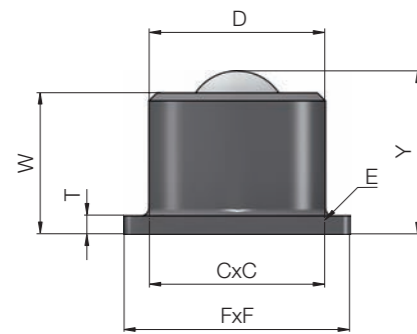

Ø Ball mm	CxC mm	D mm	E mm	FxF mm	T mm	W mm	Y mm
12.7	34.9 pcd	23.8	2 x 3.6	44.5 sq	3.2	18.6	22.6
25.4	44.5 sq	44.5	4 x 5.6	57.2 sq	4.8	35.7	41.3
25.4	57.9 sq	50.8	4 x 7.1	76.2 sq	6.4	38.1	44.5
38.1	57.9 sq	60.3	4 x 7.1	76.2 sq	12.7	48.8	61.5
50.8	101.6 sq	111.1 / 104.8 conical	4 x 11	127 sq	12.7	82.5	98.4

Dimensions
with head flange

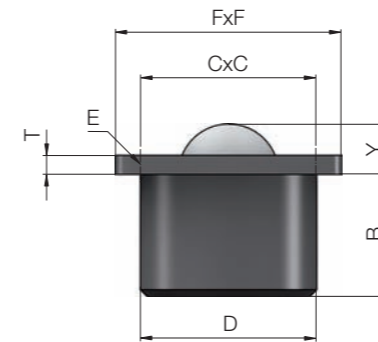

Ø Ball mm	B mm	CxC mm	D mm	E mm	FxF mm	T mm	Y mm
12.7	11.4	34.9 pcd	23.8	2 x 3.6	44.5 dia.	3.2	11.2
25.4	31.0	44.5 sq	44.5	4 x 5.6	57.2 sq	4.8	10.3
25.4	31.8	57.9 sq	50.8	4 x 7.1	76.2 sq	6.4	12.7
38.1	34.9	57.9 sq	60.3	4 x 7.1	76.2 sq	12.7	25.4
50.8	65.1	101.6 sq	110.0	4 x 10.2	127.0 sq	19.1	33.3

Dimensions with
threaded pin

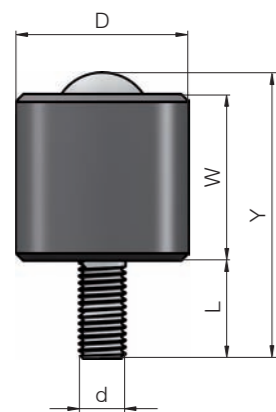

Ø Ball mm	D mm	d mm	L mm	W mm	Y mm
12.7	20.6	M8	15.9	15.1	35.0
25.4	44.5	M12	25.4	43.0	74.0
25.4	50.8	M12	25.4	45.2	77.0
38.1	60.3	M20	41.1	60.3	114.1
50.8	101.6	M24	50.8	93.3	160.0



POLYMER CONVEYOR WHEELS 2130



Other Conveying Elements
Polymer
 Conveyor Wheels

Double ball race

Product Description

- Low-noise operation
- Made of impact-resistant polymer
- Double ball race
- Based on Platform 1100

Technical Data

General technical data

Material	Polypropylene
Colour	Black
Bearing	Steel balls on a zinc-plated steel hub
Static load capacity	100 N
Dynamic load capacity	200 N
Weight	27 g

Reference number

Ø Hole mm	Fitted rubber tyre	Reference number
6.5		2130
8.2		2131
6.5	✓	2132
8.2	✓	2133

Dimensions

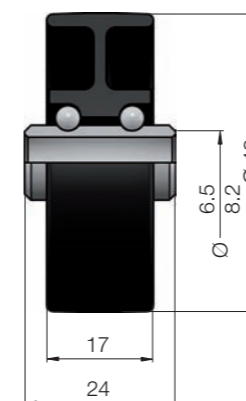



POLYMER CONVEYOR WHEELS 2370



Other Conveying
Elements
**Polymer
Conveyor Wheels**

Double ball race with spindle

Product Description

- Simple to install
- Low-noise operation
- Made of impact-resistant polymer
- Double ball race
- Floating fixing on the profile
- Shaft pin, zinc-plated, M8 15 mm
- 2 mm slit for screwdriver
- Based on Platform 1100

Technical Data

General technical data

Material	Polypropylene
Static load capacity	50 N
Dynamic load capacity	100 N

Product Selection

Version	Bearing	Colour	Weight	Reference number
Without flange	Steel balls on a zinc-plated steel pin	Black	45 g	2371
	Stainless steel balls on stainless steel pins	Grey	45 g	2373
With flange	Steel balls on a zinc-plated steel pin	Black	49 g	2370
	Stainless steel balls and stainless steel pins	Grey	49 g	2372

Dimensions

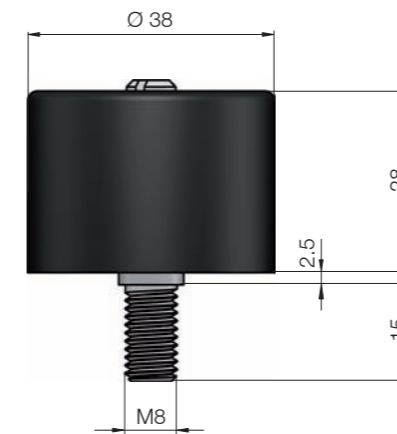

Fig.: Dimensions without flange

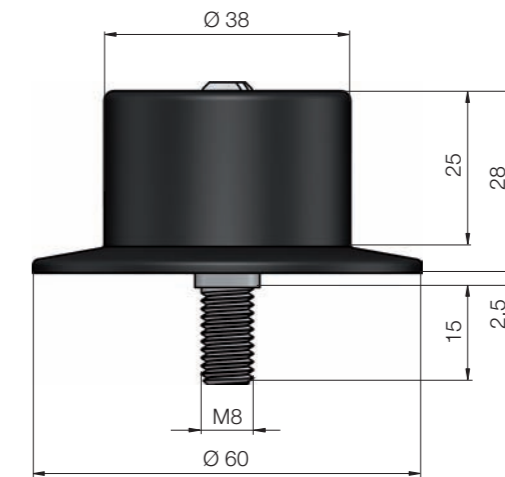

Fig.: Dimensions with flange



STEEL CONVEYOR WHEELS 2200



Other Conveying
Elements
**Steel Conveyor
Wheels**

Single-row ball race

Product Description

- Good running stability
- Long operational lifespan due to hardened running surfaces
- Single-row ball race
- Based on Platform 1200

Technical Data

General technical data

Material	Steel, zinc-plated
Bearing	Steel balls on a zinc-plated steel hub
Static load capacity	100 N
Dynamic load capacity	200 N
Weight	60 g

Reference number

Ø Hole mm	Fitted rubber tyre	Reference number
6.5		2200
8.2		2201
6.5	✓	2202
8.2	✓	2203

Dimensions

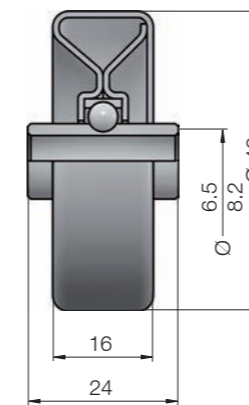



OMNIWHEEL 2500

For switchblades and intersections

Product Description

- Customer benefits**
 - Simple to install
 - Conveyance possible in every direction
 - Conveyor wheels can be coupled to each other
 - Simple construction of intersections and switchblades
- Applications**
 - Humid environment
 - Dusty environment
 - Version driven in one direction with a hexagonal shaft
- Properties**
 - Corrosion-proof due to the use of stainless steel pins
 - Based on Platform 1500
- Design information**
 - Level, stable base required on material to be conveyed
 - The load capacity is used to best advantage if coactive Omniwheels have exactly the same level and the surfaces of the material to be conveyed are smooth

Dimensions

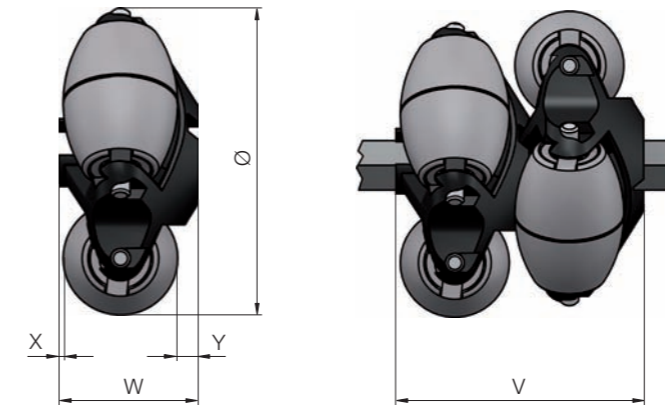

Ø Roller mm	X mm	Y mm	W mm	V mm
48	3	3	21.5	40
80	4	4	34	65

Technical Data

General technical data

Frame material	Polyamide
Tube material	Polyamide
Plug material	Steel, stainless steel
Bearing	Slide bearing

Product Selection

Ø Roller mm	Hub opening mm	Max. load capacity N	Reference number
48	8.2	50	2570
48	8.1 hex	50	2571
80	12.2	250	2580
80	11.2 hex	250	2581



OMNIMAT MODULE 2800

For switchblades and intersections

Product Description

- Customer benefits**
 - Conveyance possible in every direction
 - Lateral dovetail profiles for a fixed, form-fit join
- Applications**
 - Humid environment
- Properties**
 - Corrosion-proof
 - Equipped with a pair of OmniWheels Series 2500 (Ø 48 mm) and stainless steel shaft (Ø 8 mm)
- Design information**
 - Level, stable base required on material to be conveyed

Technical Data

General technical data

Max. load capacity	50 N
Bearing	Slide bearing
Housing material	Polypropylene

Dimensions

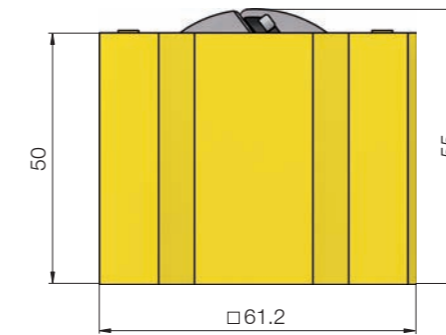

Reference number: 2800



ROLLER TRACKS BU40

Push conveyor tracks for lightweight and medium-heavy containers

Product Description

- Customer benefits Applications**
- For universal use
 - Suitable for lightweight and medium-heavy materials to be conveyed
 - For inclined conveyors and pushing operations
 - Side guides
- Properties**
- Zinc-plated steel profile
 - Snap-in function for wheels in the profile
 - Standard pitch 52 mm
 - Conveyor wheels used
 - Polymer Wheels Series 2130
 - Steel Wheels Series 2200

Technical Data

General technical data

Material	Steel, zinc-plated
Wall thickness	1,2 mm
Standard pitch	52 mm

Load capacity Load capacity diagram (surface load-deflection 2 mm)

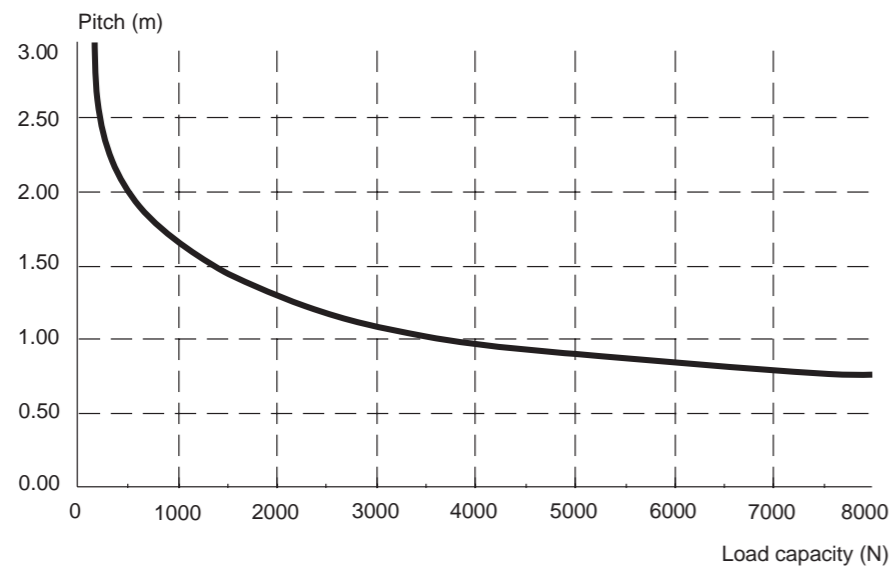

Reference number

Please state in addition to the reference number the total length L (has to be a multiple of 52 mm) and the number of conveyor wheels.

Version	Reference number
With polymer conveyor wheels	BU40, L = XX mm, XX no. 2131
With steel conveyor wheels	BU40, L = XX mm, XX no. 2201

Ordering information

Dimensions

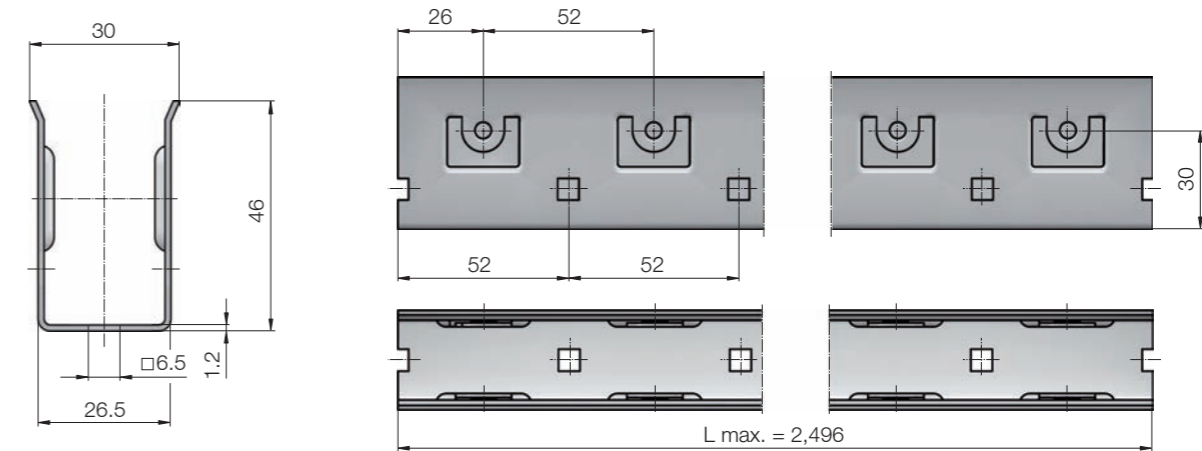

Fig.: Dimensions of steel profile Fig.: Dimensions of Roller Track

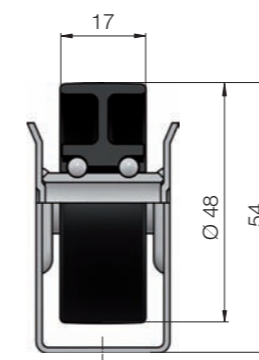

Fig.: Dimensions with polymer conveyor wheels

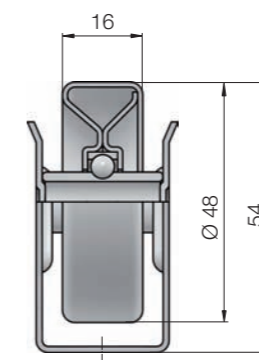

Fig.: Dimensions with steel conveyor wheels



ROLLER TRACKS BU50

Push conveyor tracks and diverter equipment
for medium-heavy and heavy pallets

Product Description

- Customer benefits**
- For universal use
 - Different pitches are possible
- Applications**
- Suitable for medium-heavy and heavy materials to be conveyed
 - For inclined conveyors and pushing operations
 - Side guides
- Properties**
- Zinc-plated steel profile
 - Rollers riveted in the profile, rivet shafts 8 mm
 - Platform 1700 conveyor rollers used:
 - Polymer conveyor rollers (Ø 50 mm) with or without flange; static load capacity 300 N / dynamic load capacity: 400 N
 - Conveyor rollers with steel tube (Ø 50 mm); static load capacity: 1,200 N / dynamic load capacity: 1,600 N

Technical Data

General technical data

Material	Steel, zinc-plated
Wall thickness	2,5 mm
Standard pitch	52, 78, 104, 156 mm

Load capacity

Load capacity diagram (surface load-deflection 2 mm)

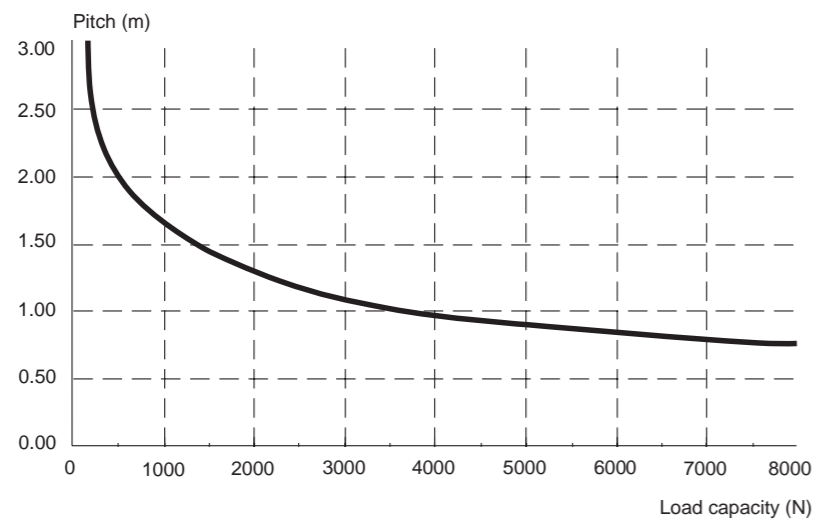

Reference number

Please contact your Interroll customer consultant.

Version

- Polymer conveyor roller without flange
- Polymer conveyor roller with flange
- Steel conveyor roller

Dimensions

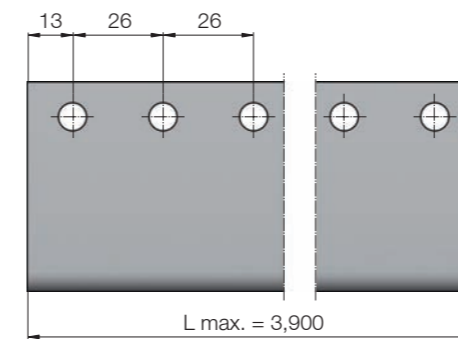

Fig.: Dimensions of Roller Track

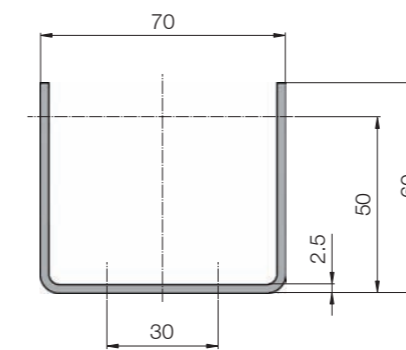

Fig.: Dimensions of steel profile

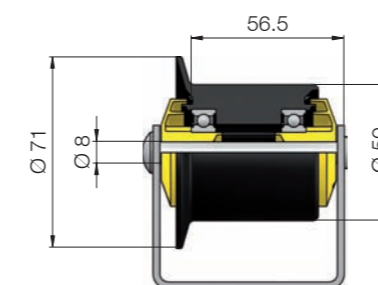

Fig.: Dimensions with polymer conveyor roller with flange

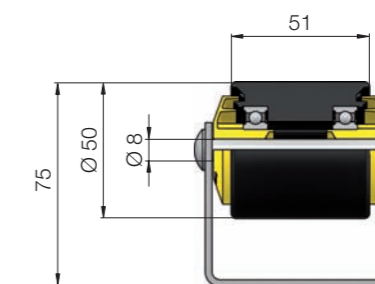
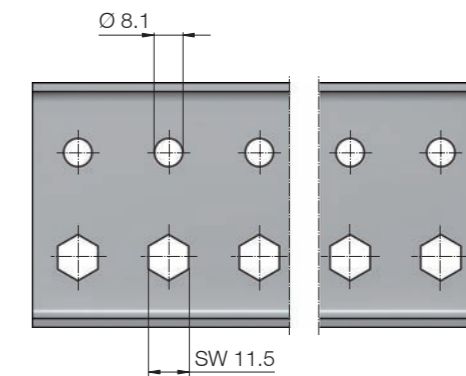

Fig.: Dimensions with polymer conveyor roller without flange

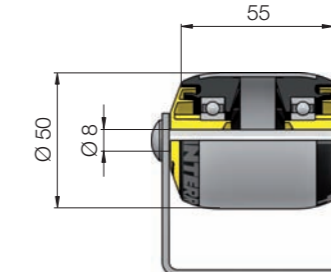

Fig.: Dimensions with steel conveyor roller



FLOWAY

For order picking shelves and roller carpets

Product Description

- Customer benefits**
 - Supports the lateral profile flanges on the shaft
 - Guarantees the free-running of the wheels even under heavy loads
- Applications**
 - Wheel tracks for order picking shelves
 - Roller carpets for gravity and pushing operations
 - For lightweight and medium-heavy materials to be conveyed
 - For inclined conveyors and pushing operations
- Properties**
 - Wheels made of highly compressed polyethylene
 - Zinc-plated steel profile
 - Continuous, zinc-plated, 3 mm shaft

Technical Data

General technical data

Material	Polyamide
Standard pitch	28 mm
Roller colour	Black
Max. load capacity per wheel	80 N

Load capacity

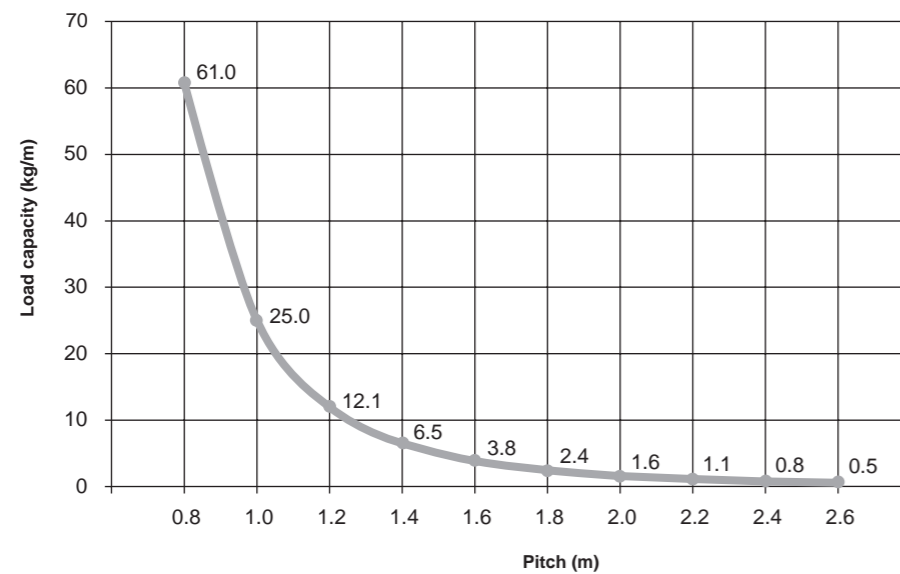

Ordering information Please clarify the profile length with your Interroll customer consultant.

Dimensions

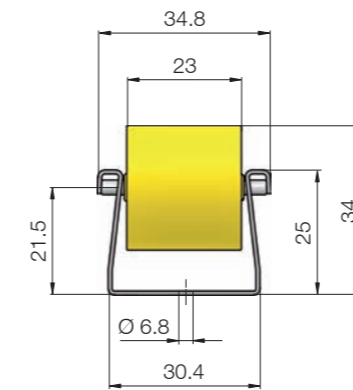

Fig.: Wheel

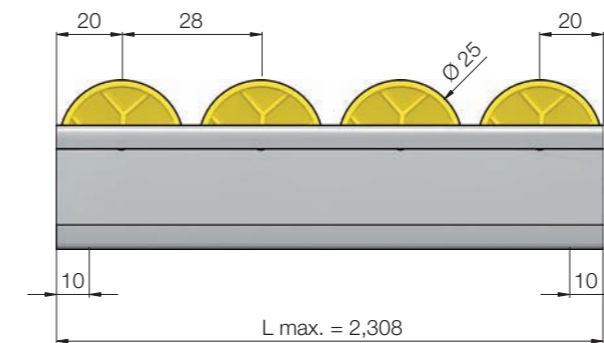

Fig.: Wheel track

CONVEYOR ROLLER ACCESSORIES

PolyVee Belts

Product Description

- Standard belt: ISO 9981; DIN 7867
 - Flexible standard belt
 - Significantly longer service life than round belts
 - Up to 300 % more torque transmission than with comparable round belts
 - Flexible standard belts, 1 to 3% pre-tension
 - Also suitable as curve drive (only 2-ribbed belts)

Product Selection

Number of ribs	Max. weight of material to be conveyed kg	Roller pitch mm	Reference number
2	50	60	H68B
		75	H68C
		100	H68D
		120-125	H68E
3	300	60	H68F
		75	H68G
		100	H68H
		120-125	H68J

Flanges

Product Description

- Stable complete flanges for tubes Ø 50, 60, 80 and 89 mm
- Welded right round to the tube
- Stable side guide prevents the conveyed material from being laterally displaced
- They can be ordered for the following Conveyor Roller Series:
 - Steel Conveyor Roller Series 1200
 - Universal Conveyor Roller Series 1700
 - Fixed Drive Conveyor Roller Series 3500
 - Gravity Conveyor Roller Series 1450

With regard to the pitch, it must be ensured that at least 2 conveyor rollers with flange are in contact with the conveyed material

Dimensions

Please state dimensions A + D when ordering.

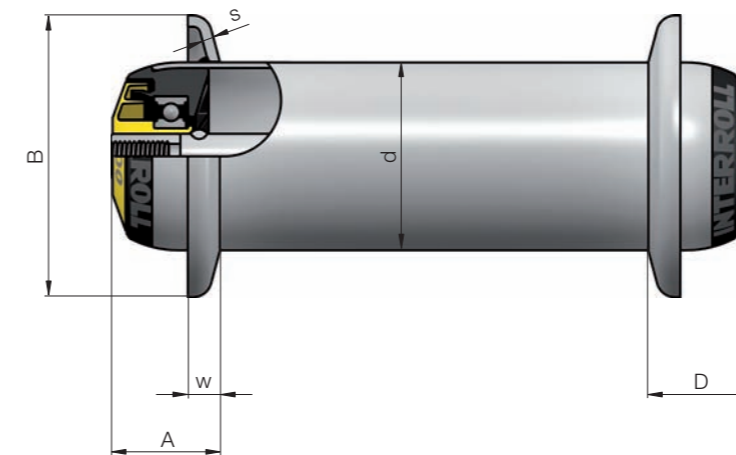

d mm	B mm	s mm	w mm	A _{min} mm	D _{min} mm
50	75	3	8.5	22	22
60	100	3	8.5	22	22
80/89	150	4	18	30	30

Design
information

Ordering
information

CONVEYOR ROLLER ACCESSORIES

Variable Shaft Projection

Product Description

- Shaft projections can deviate from the standard by being extended or shortened
- They can be ordered for the following Conveyor Roller Series:
 - Smooth-Running Conveyor Roller Series 1100
 - Steel Conveyor Roller Series 1200
 - Universal Conveyor Roller Series 1700
- They can be ordered for the following shaft versions:
 - Female threaded shaft
 - Male threaded shaft
 - Spring-loaded shaft
 - Flatted shaft

Ordering information

The possible shaft projections depend on the actual shaft version. Please contact your Interroll customer consultant.

Design information

Axial support by the seal can no longer be guaranteed with a variable shaft projection. With greater axial forces, for example where there is lateral displacement, suitable replacement structures, such as spacing tubes, may possibly have to be fitted.

Shaft adapter

Product Description

- Suitable profile construction with open longitudinal holes
- Low noise level
- Conductive polymer shaft adapter made of polyoxy methylene, fitted on a rigid shaft
- Increases the installation length
- The shaft adapters are not an alternative to the tapered shaft shuttle of Series 1700 p 38
- The conveyor rollers are laid loosely into the profiles from above

Product Selection

Ø Shaft mm	External dimension mm	EL mm	Reference number
8	11 hex, 11 long	+5	K258
10	SW12 x 8	+4	K247

Antistatic Element

Product Description

- Brass ball for conducting away electrical energy from the surface of the tube
- Permanent join between steel tube and shaft
- All conveyor rollers have grooves on the tube as standard
- This can be ordered for all conveyor rollers series (with the exception of Series 1500) and for all tube diameters

Please contact your Interroll customer consultant.

The electrical energy has to be conducted from the shaft into the profile. The excellent conductivity from the roller shaft into the frame profile must be ensured by the plant constructor by putting in place suitable measures.

Customer benefits

Properties

Design information

Ordering information Design information

ROLLERDRIVE ACCESSORIES

Cables for Z-Card

Product Description

- All cables are provided with appropriate connectors and protective sleeves at both ends and are ready for installation

Product Selection

Cable	Description	Reference number
Communication cable	From Z-Card to Z-Card	89VC
Sensor connection cable	For M8 sensors, length 1 m	89VA
	For M8 sensors, length 2 m	89VB
Connection cable for power unit	Length 1 m, open-stranded	89VJ

Extension cable for RollerDrive EC310

Product Description

- Protection rating: IP66
- Length: 2 m
- Connection: Plug system at both ends

Reference number: 89VN

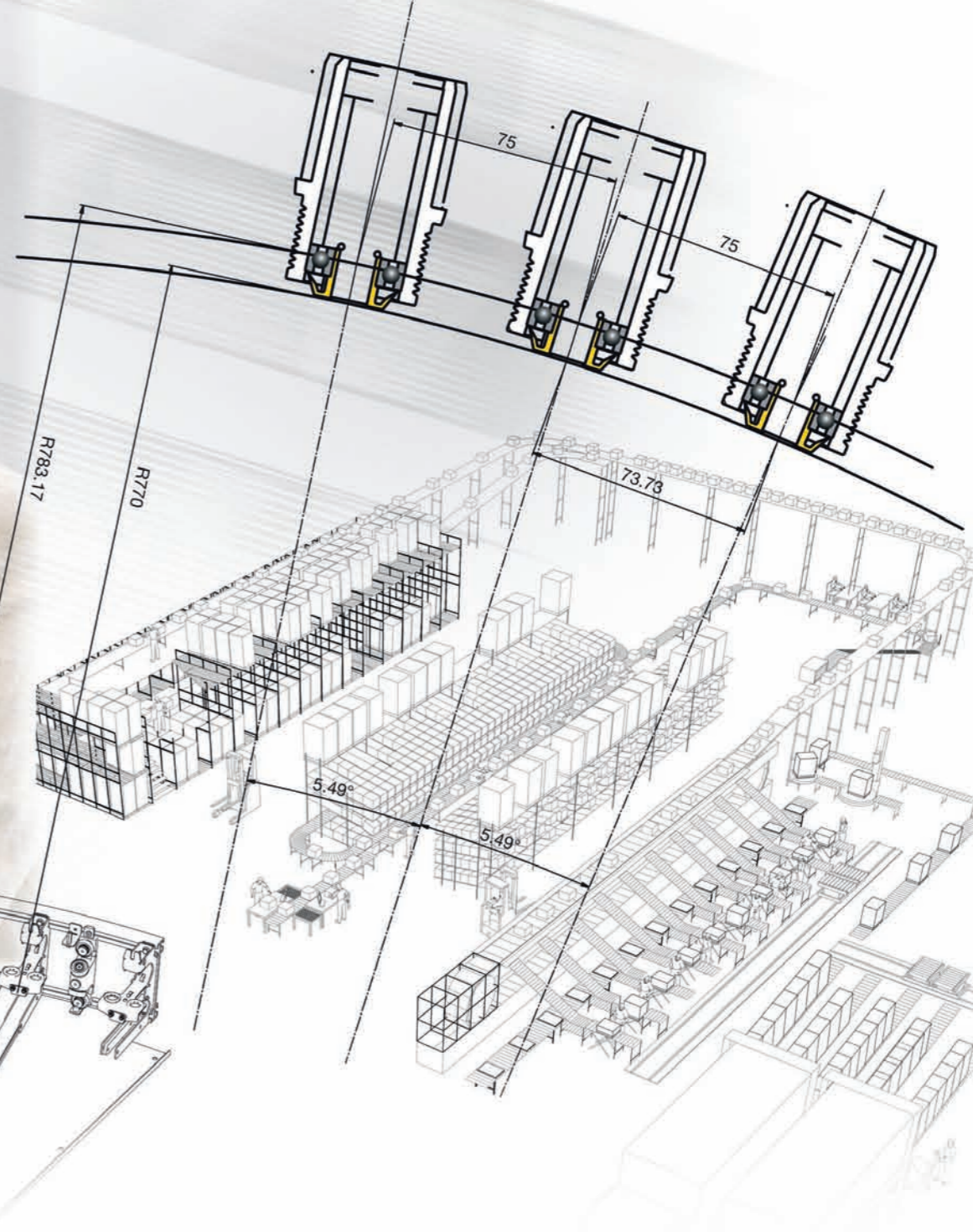

PLANNING SECTION AND MATERIAL SPECIFICATION

What is the purpose of the Planning Section?

The Planning Section assists you in your planning and design of conveyor installations and in the selection of components. The Planning Section provides you with:

- Decision-making aids for product selection
- Extensive product and material descriptions
- Information on applications, applicational criteria and limits
- Orientation around the catalogue

What is the purpose of the Material Specification?

The Material Specification is intended as a reference document. Here you can find concise and detailed information about the materials used in Interroll products. The information is sub-divided under the headings Tubes, Bearings, Shafts, Drives and Polymer.

Planning Basics

Dimensions of Your Material to be Transported	p 172
Weight of Your Materials to be Transported	p 173
Material of Your Transported Product	p 174
Requirements Regarding the Conveyor System/Environmental Conditions	p 175

Construction Principles

for straight conveyor sections	p 208
for Magnetic Speed Controller 50	p 214
for curves	p 216
for RollerDrive and Controls	p 222

Planning Information

Platforms	p 176
Tubes	p 180
Tube Materials/Tube Sleeves	p 180
Tubes with Flanges/Grooves	p 186
Bearing	p 188
Drives	p 190
Shafts	p 202

Material Specification

Tubes	p 226
Bearing	p 227
Shafts	p 228
Drives	p 229
Technical Polymer	p 230

PLANNING BASICS

The properties of your material to be transported, your requirements as regards the conveyor system and the ambient conditions are the basis for the planning of your system. Consider the following questions and the resulting conditions for selection of your product in order to find the best possible solution for your conveyor installation.

Dimensions of Your Material to be Transported

What is the length and width of your material to be transported?

The length and width of the material to be transported have an effect on three factors:

- **Straight running:** The higher the ratio of length to width, the more stable will be the straight running of your items. With smaller length to width ratios, you may have to consider putting in place additional measures to stabilise the straight running of the materials.
- **Reference length :** The reference length normally corresponds to the width of the product to be transported + 50 mm or, with very large items such as pallets + 100 mm. Tapered conveyor rollers must be used in curves, the length of which has to be calculated separately (cf. Planning Section, p 216).
- **Roller pitch:** To ensure that the material to be transported is conveyed smoothly, the roller pitch has to be designed so that at least three conveyor rollers lie under the product at all times.

What is the height of the material to be transported?

The greater the height of the material to be transported in relation to its footprint, the higher is the risk of it tipping over when travelling on the conveyor. The following must be taken into consideration:

- Minimise the roller pitch as much as possible to ensure that the products are conveyed smoothly with as large a base surface as possible on the conveyor.
- Avoid rapid acceleration and harsh braking.
- With inclined conveyor tracks, determine the centre of gravity of the material to be transported and check whether there is a risk of it tipping.

Weight of Your Materials to be Transported

The weight of the material to be transported affects in particular the:

- **Diameter, pitch and bearing load:** The weight of the material to be transported must be distributed over as many load-bearing conveyor rollers as are required to ensure that the maximum load capacity of the individual rollers is not exceeded. This may mean that material to be transported may have to be supported by more than three conveyor rollers. The greater the diameter of the tube selected, the higher is its load capacity. The load capacity is also increased by threaded shafts, which provide additional reinforcement for the conveyor and act as cross ties.
- **Drive:** A wide range of different drives are available with Interroll products. However, these drives must fit to the application.

Uneven weight distribution of the material to be transported?

- In principle the weight of the material to be transported/container should be distributed as evenly as possible. The more uneven is the weight distribution, the more difficult is the reliable conveyance. With pallets, it should be borne in mind that only the rollers under the bulk of the pallet are actually bearing the load (euro-pallet). Thus the proportion of load-bearing rollers when transporting pallets is generally restricted to a maximum of four rollers.

What is the weight of your material to be transported?

What is the weight distribution of the material to be transported?

PLANNING BASICS

Material of Your Transported Product

What is the material of the goods to be transported?

The material, and especially the condition of the base, has an effect on the rolling and starting resistance:

- **Drive, diameter and pitch:** Rigid materials, such as polymer containers, have a lower rolling and starting resistance than soft materials, such as boxes. This has a direct effect on the drive output required and must be incorporated into your calculation. The softer the underside of the material to be transported, the higher is the drive output required for a product with the same weight but with a hard underside. Furthermore, in principle the softer the material to be transported is, the smaller the roller pitch selected needs to be.
- **Load capacity and pitch:** Ribs, grooves, ridges or grooves on the base of the material to be transported are not a problem providing they run parallel to the conveyor direction. The drive output required may have to be increased depending on their shape, especially with cross ribs. Cross ribs can have an adverse effect on the conveying action and the roller pitch may possibly have to be calculated by experience.

Your Requirements Regarding the Conveyor System

The following parameters determine the specification of your conveyor system:

- Maximum throughput per time unit
- Geometry of the material to be transported
- Weight and material of the transported product
- Control requirements
- Environmental conditions

Electrostatic charges are fundamentally produced when an object is transported on rollers.

- **Antistatic version:** Interroll offers antistatic versions of all products to conduct away electrostatic charges immediately without sparking. Conveyor rollers driven by grooves are basically designed to be antistatic. The charge is conducted with low ohm resistance from the tube to the shaft by means of an antistatic element. The profile opening, into which the roller is laid or screwed, has to have uncoated surfaces in order to conduct the charge without sparking into the earthed side profile. This is the responsibility of the plant manufacturer.

The development of noise is affected by the:

- **Drive:** Every drive causes noise, although Interroll drives are designed to be especially low-noise. In principle, A chain drive creates more noise than a belt drive, such as a PolyVee or round belt.
- **Material and bearing:** Almost all Interroll products use technopolymers between the metallic parts to achieve the best possible noise levels.

Damp materials to be transported or humid surroundings affect the:

- **Material and bearing:** Conveyor rollers with precision ball bearings are ideally protected from wet and dirt under normal ambient conditions. If the components of the system will be constantly exposed to humidity and wetness, then Interroll offers stainless ball bearings and tubes and shafts made of corrosion-proof materials.

In principle, conveyor rollers can be used at temperature ranging from -28 to +40 °C. The relevant applicable temperature ranges are given on the product pages for the various Conveyor Roller Series. Please contact your Interroll customer consultant for non-standard temperature conditions.

What length or throughput should the installation have?

Is there static charge?

Does the system have to be low-noise?

Does the system have to be corrosion-resistant?

Will be system be operating in extreme temperatures?

PLATFORMS

Interroll Conveyor Roller Series are arranged into five so-called “platforms”. Each platform is characterised by a certain type of bearing and certain materials – the two key factors for the operation and applicational possibilities of the products.

The following applies within a platform:

- The bearings and materials for the bearing housing and seal are identical
- The shapes of the bearings may differ
- The versions are produced by the combination of shaft and tube dimensions as well as the materials

**Platform 1100
for Non-Driven
Conveyors**

Applications

For gravity applications

- For especially lightweight and silent operation of conveyor rollers
- Stainless steel version suitable for moist areas
- For lightweight and medium-heavy materials to be transported
- Not suitable for driven conveyors

Ball bearings and materials

The ball bearings are made of polymer with steel or stainless steel balls. The outer ring and cone of the bearing is made of polypropylene or POM. The bearings are lubricated with a food-safe grease.

Properties

Platform 1100 provides for lightweight and particularly silent running of conveyor rollers for gravity systems operating in normal ambient temperatures.

Please refer to p 230 for the properties and applications of polymer.

Max. conveyor speed at a diameter of 20 mm	0.1 m/s
Max. conveyor speed at a diameter of 50 mm	0.3 m/s
Max. load capacity	350 N
Temperature range	-5 to +40 °C

Associated Conveyor Roller Series

- Smooth-Running Conveyor Roller Series 1100 p 28
- Conveyor Wheels Series 2130 p 148
- Conveyor Wheels Series 2370 p 150

Applications

For temperature ranges outside of the limits for polymer

- For non-driven and driven conveyors
- For lightweight and medium-heavy materials to be transported

Ball bearings and materials

The pressed bearing seat and internal rings of the metal ball bearing are hardened and galvanized zinc-plated. The shape of the ball bearing is designed specifically for conveyor rollers and tolerates greater deflection of the bearing than comparable precision ball bearings. However the conveyor speeds are restricted. The noise level is significantly higher than with conveyor rollers with polymer housings because of the steel construction throughout.

Properties

Platform 1200 is specifically designed for use in extreme ambient temperatures.

Max. conveyor speed at a diameter of 30 mm	0.3 m/s
Max. conveyor speed at a diameter of 50 mm	0.8 m/s
Max. load capacity	1,200 N
Temperature range	-28 to +80 °C

Associated Conveyor Roller Series

- Steel Conveyor Roller Series 1200 p 32
- Steel Conveyor Wheel Series 2200 p 152

Applications

- For wet and hygienic areas
- For non-driven and driven conveyors
- For lightweight and medium-heavy materials to be transported

Ball bearings and materials

The ball bearings are designed as slide bearings and are made of polymer (polyamide or POM + PTFE) with a stainless steel shaft pin. The materials and surfaces of the bearing pair are aligned to each other so that the bearings can run dry without lubrication. All of the materials are corrosion-proof. The conveyor rollers are completely corrosion-proof if polymer or stainless steel tubes are used.

Properties

Platform 1500 is specifically designed for use in hygienic areas and in areas at risk of corrosion. All of the bearing housings are sealed internally so that liquids or other substances cannot penetrate the rollers. The conveyor rollers can be cleaned with conventional detergents.

Please refer to p 230 for the properties and applications of polymer.

Max. conveyor speed at a diameter of 30 mm	0.3 m/s
Max. conveyor speed at a diameter of 50 mm	0.8 m/s
Max. load capacity	120 N
Temperature range	-10 to +40 °C

Associated Conveyor Roller Series

- Slide Bearing Conveyor Roller Series 1500 p 36
- OmniWheel Series 2500 p 154

PLATFORMS

Platform 1700 for Universal Use

Applications

- For driven and non-driven conveyors
- For particularly light conveyance at high conveyor speeds
- For lightweight and medium-heavy materials to be transported
- Large number of applications

Ball bearings and materials

The ball bearings are sealed DIN precision ball bearings 6002 2RZ, 689 2Z and 6003 2RZ. All of the ball bearings are greased with a silicon-free lubricant and have a secure bearing housing in the base of the roller thanks to a snap-on edge. The ball bearing 6002 2RZ is also available as an oiled version and in stainless steel.

The integral polypropylene seal is fixed in the internal ring of the ball bearing and has three functions:

- Protecting the ball bearing from coarse dirt and spray water
- Diameter compensation between the shaft and the internal ring of the ball bearing
- Diverting axial forces into the ball bearing

Properties

Platform 1700 is designed for high loads at very low noise levels and provides the ultimate in applicational flexibility. The bearing design comprising polyamide bearing housing, precision ball bearing and a polypropylene or POM seal produces an extremely quiet conveyor roller, which can simultaneously carry heavy loads.

The bearing housings and the belt drive heads are incorporated in a form-fit manner into the tubes in the standard version. The unique feature about this platform 1700 is the tapered shaft-shuttle, which combines the benefits of a female threaded shaft and a spring-loaded shaft (cf. shaft-shuttle shaft design p 204).

Please refer to p 230 for the properties and applications of polymer.

Max. conveyor speed	2.0 m/s
Max. load capacity	3,000 N
Temperature range	-5 to +40 °C

Associated Conveyor Roller Series

- Universal Conveyor Roller Series 1700 p 38
- Universal Conveyor Roller Series 1700 light p 18
- Tapered Conveyor Roller Series 1700KXO p 46
- Fixed Drive Conveyor Roller Series 3500 p 50
- Tapered Conveyor Roller Series 3500KXO p 58
- Tapered Conveyor Roller Series 3500 KXO light p 22
- Fixed Drive Conveyor Roller Series 3560 p 62
- Friction Conveyor Roller Series 3800 p 66
- Double Friction Conveyor Roller Series 3860 p 74
- Double Friction Conveyor Roller Series 3870 p 78
- RollerDrive 24 V DC p 86

Applications

- For driven and non-driven conveyors
- For particularly heavy-duty loads and heavy individual loads
- Suitable for extreme temperatures with steel bearing housings

Ball bearings and materials

The standard version bearings are precision ball bearings 6205 2RZ or 6204 2RZ. The drive elements, such as sprockets or toothed belt heads, are made of fibreglass-reinforced polyamide or POM in Series 3600 and are made of steel in Series 3950. The bearing seat on the non-driven side and the seal are made of polyamide.

Properties

Platform 1450 is specifically designed for very high loads caused by heavy individual weights. One version is designed for refrigerated applications.

The technopolymer drive elements are designed to be twist-proof by being joined to the tube in a form-fit manner. The steel drive heads and flanges are all galvanized zinc-plated after being welded to the tube for optimum corrosion protection. All of the welds run right around the tube, not just in certain areas.

Please refer to p 230 for the properties and applications of polymer.

Max. conveyor speed	0.5 m/s
Max. load capacity	5,000 N
Temperature range of standard version	-5 to +40 °C
Temperature range of steel bearing housing	-28 to +40 °C

Associated Conveyor Roller Series

- Heavy-Duty Conveyor Roller Series 1450 p 120
- Heavy-Duty Conveyor Roller Series 3600 p 128
- Heavy-Duty Conveyor Roller Series 3950 p 132

Platform 1450 for the Heaviest Loads

TUBES

Tube Materials

The tube material and tube diameter determine the load capacity and operation of the conveyor rollers. The following section outlines the tube materials steel, aluminium and polymer, together with their advantages and disadvantages.

- Steel**
- Best strength and flexural strength of all tube materials
 - Corrosion protection can be provided by zinc plating or the use of stainless steel
 - Sprockets and flanges can be welded onto the tube

Steel tubes used on Interroll conveyor rollers are manufactured in accordance with DIN EN 10305+1 and DIN EN 10305-3 with limited tolerances (as specified by Interroll).

Other versions: Tubes with grooves, tubes with flexible sleeves, rubberised tubes, surface-hardened tubes, brushed stainless tubes.

When belt conveyors are used, there is noise caused by the pared tube welds coming into contact with the belt. Interroll therefore recommends that the plant constructor tests the relevant application.

- Aluminium**
- Significantly lighter than steel tube
 - Corrosion-resistant

Aluminium tubes have slightly lower strength and only about one third of the flexural strength of steel tubes. However, they weigh only 36 % of the weight of comparable steel tubes.

Aluminium tubes up to and including a diameter of 30 mm have anodised surfaces. Aluminium tubes with a diameter of 50 mm are not anodised and can therefore discharge electrostatic charges via the connection with the roller shaft.

- PVC**
- Sound reduction
 - Highly impact-resistant
 - Lower weight
 - Corrosion-resistant
 - Easy to clean

Polymer tubes have a significantly lower load capacity compared with steel tubes with the same diameter.

On tubes with a diameter of more than 30 mm, the bearing assemblies are joined to the tube in a form-fit manner thus ensuring a completely secure seating.

Tube sleeves

A tube sleeve is recommended to improve the tube surface for specific applications:

- Push-on sleeves (PVC and PU)
- Rubber coating
- Hardened tube surface
- Brushed stainless steel tubes

Applications

- For especially good noise levels
- As protection for sensitive material to be transported
- For significantly improved conveyance and sorting of the materials to be transported
- For conveyor rollers with a diameter of more than 30 mm to max. 1,700 mm in length
- Only suitable for zinc-plated steel tubes and stainless steel tubes

Procedure

The tube is blown onto the conveyor roller - it is therefore not glued on. In this process, the completely finished conveyor roller is pushed by a pneumatic pressing machine into the tube, which has been expanded with compressed air. Then the sleeve is cut to the length of the tube or to the specified dimension (A - D).

Even conveyor rollers with welded drive elements can be encased in a PVC sleeve if the diameter of the drive element is not more than 10 mm larger than the bearing tube.

Properties

- Improved conveyance of the material on the conveyor due to the significantly improved coefficient of friction of the PVC surface compared with a steel surface
- Higher peripheral velocity due to the larger external diameter and thus improved sorting of the material to be transported at the same speed

Material	Soft PVC Processing agents Silicone- and halogen-free Non-food safe and non-conductive
Resistance	Not oil- and petrol-resistant
Hardness	63 ± 5 Shore A
Colour	Dust grey, RAL 7037, matt
Tube diameter	30, 40, 50, 60, 80 mm
Wall thickness	2 mm, 5 mm
Temperature range	-25 to +50 °C Risk of fracture when cold at -30 °C

Ordering information

Should the sleeve not be intended to cover the entire tube length, the relevant dimensions for the sleeve should be specified when ordering. Often clearance is needed for grooving, drive belts etc., for example. If no dimensions are specified, the sleeve will be cut so that it covers the entire length of the tube.

The minimum width of the sleeve is 50 mm in order to ensure that the sleeve sits firmly. In individual cases, a greater width may have to be selected if axial forces are to be exerted on the sleeve, e. g. in the event of lateral displacement or lateral feed.

PVC push-on sleeves

TUBES

PU Push-on sleeves

Applications

- For sound attenuation, particularly with steel containers
- As protection for sensitive material to be transported
- For slightly improved conveyance and sorting of the materials to be transported
- For conveyor rollers with a diameter of 50 mm up to 1,700 mm in length
- Only suitable for zinc-plated steel tubes and stainless steel tubes

Procedure

The tube is blown onto the conveyor roller - it is therefore not glued on. In this process, the completely finished conveyor roller is pushed by a pneumatic pressing machine into the tube, which has been expanded with compressed air. Then the sleeve is cut to the length of the tube or to the specified dimension (A - D).

Properties

- Significantly more rigid than PVC sleeves
- Slightly improved conveyance of the material to be transported due to the improved coefficient of friction of the PU surface compared with a steel surface
- Higher peripheral velocity due to the larger external diameter and thus improved sorting of the materials to be transported at the same speed

Material	Polyurethane, softener-free, stabiliser-free Silicone- and halogen-free Food-safe (according to FDA)
Resistance	Oil- and grease-resistant
Hardness	75 ± 5 Shore A
Colour	Black, RAL 9005, gloss
Tube diameter	50 mm
Permissible deviation of internal diameter	47 ± 1.00 mm
Wall thickness of PU sleeve	2 mm
Permissible deviation of wall thickness	2 +0.30 mm / -0 mm
Temperature range	-25 to +80 °C

Rubber coating

Applications

- For noise reduction
- As protection for medium-heavy and heavy materials to be transported
- For the improved conveyance and sorting of the materials to be transported
- For heavy loads
- For applications, which require highly abrasion-resistant surfaces
- For conveyor rollers with uncoated steel, ground surfaces of up to max. 1,250 mm in length

Procedure

The rubber coating is applied in a curing process, which produces a high-strength joint between the rubber coating (NBR) and the tube. This produces a highly abrasion-resistant surface. The projecting sections of tube and the drive heads are protected from corrosion by a black paint finish.

Properties

- Significantly higher load capacity than with push-on sleeves
- Exceptionally small diameter tolerances
- Application-dependent chemical resistance

Hardness	65 ± 5 Shore A
Resistance	
Oil/grease, petrol	-
Alkali	+
Aromatics	-
Ketones	+
Acids	+
Colour	Black
Tube diameter	30, 40, 50, 60, 80, 89 mm
Wall thickness	2, 3, 4, 5 mm
Diameter tolerance (ground)	+0.50 mm / -0 mm
Temperature range	Up to +100 °C

Applications

- For higher load capacity on steel tube rollers, e. g. for steel containers
- For conveyor rollers up to a maximum of 2,600 mm in length

Procedure

The tube surface is hardened by nitro carbonation. The layer thickness is approx. 10 to 20 µm. The hardened surface is matt, light grey and scale-free. Subsequent grinding is not required and is not offered by Interroll.

The bearing housings are pre-flanged with tube wall thickness of up to 1.5 mm, and with greater wall thicknesses, bearing housings with a straight seating in the tube are used.

Properties

- Abrasion-resistant surfaces
- Excellent continuous vibration resistance
- Good sliding properties
- Excellent temperature resistance
- Low warpage
- Good corrosion resistance
- Not suitable for zinc plating

Hardness test

The hardness test on nitro-carburated layers is conducted according to the Vickers process (HV). 50 N has proved itself as a suitable test load (HV5). Higher test loads can result in falsified readings, as the core hardness has a significant effect on the test results. The hardness in the peripheral zone of 10 - 20 µm is approx. 650 - 700 HV1 (57 - 60 HRC).

Hardened tube surfaces

TUBES

Brushed stainless steel tubes

Applications

- For visually uniform surfaces
- For improved conveyance of the materials to be transported
- For long-lasting corrosion resistance

Procedure

The finished sawn tubes are conveyed sideways past a belt grinder, resulting in an evenly brushed surface. The roughness of the surface is increased by the grinding, thereby improving the conveyance of the materials to be transported. The tolerances with regard to roundness or concentric precision are unaffected by this.

Properties

The brushing removes deviations in colour and differences in the sheen of the surfaces as well as any printing of material classifications.

Tube diameter	30, 40, 50, 60, 80, 89 mm
Max. reference length up to a diameter of 50 mm	1,500 mm
Max. reference length above a diameter of 50 mm	1,000 mm

Corrosion Protection

The following is available as corrosion protection:

- Zinc plating of steel tubes
- Stainless steel tubes as especially durable protection

Zinc plating

Applications

- Cost-effective corrosion protection
- For dry areas with normal temperatures
- Limited suitability for environments with salt and humidity, e. g. installations in harbour areas or in sub-tropical countries
- Limited suitability for the transport of damp/wet materials

Procedure

The surface of the material is zinc plated galvanically by electrolysis. The electrolysis produces an extremely even, thin sleeve. The entire process involves pre-treatment, zinc plating, passivation and drying.

Properties

Galvanized zinc plating produces temporary protection from corrosion of both the zinc and the iron. The duration of the corrosion protection is affected by the mechanical and thermal loads to which it is subjected. Zinc plated surfaces are sensitive to scratching and abrasion. Damage can result in point corrosion.

Extreme changes in temperature must be avoided as they can cause internal tension. Furthermore, corrosion resistance becomes reduced as the temperature rises.

In order to maintain the limited protective effects of zinc plating, special packaging must be used for sea freight, for example. Special measures must also be employed if the materials are to be stored for a longer period of time. Zinc plating is not food-compatible.

A zinc plated and passivated surfaced reacts with:

- Air humidity
- Acidic environments (exhaust fumes, salts, wood acid etc.)
- Alkaline substances (lime, chalk, cleaning agents, COs)
- Perspiration
- Solutions of other metals (copper, iron etc.)

Layer thickness	6 to 15 µm
Passivation	Additional blue passivation (chromium(IV)-free)
Standards complied with	DIN EN 12329 DIN 50961 Sleeve complies with RoHS regulations
Temperature range	-40 to +200 °C

Applications

- Long-lasting corrosion protection
- Aggressive environments
- Moist areas

Properties

Stainless steel tubes provide lasting protection against corrosion and extended chemical resistance.

Tube diameter	30, 40, 50, 60, 80, 89 mm
Material	1.4301 (X5CrNi18-10)

Stainless steel tubes

TUBES

Tubes with Flanges

- To prevent the lateral displacement of the materials to be transported

To ensure steady side guidance, all of the flanges are welded all-round with the tube.

The number of flanges and the roller pitch has to be selected in such a way that at least two flanges always guide the material to be transported at any time.

Tube diameter	50, 60, 80, 89 mm
---------------	-------------------



Tubes with Grooves

- For driven conveyors with round belts

Grooving refers to running grooves to guide round belts underneath the surface of the tube. A differentiation is made on conveyors with round belts between roller-to-roller belts and roller-to-roller with a driven shaft running continuously underneath the conveyor rollers (line shaft, upright shaft).

Interroll recommends the Universal Conveyor Roller Series 1700 with grooves for round belt drives:

- With antistatic conveyor rollers
- Max. conveyor force of the round belt 300 N
- The maximum load capacity per conveyor roller with grooves is 300 N, owing to the poor conveying power of the round belt.
- The maximum load capacity of the conveyor roller is lower with tube lengths of greater than 1,400 mm
- Interroll recommends a shaft version that is secured against twisting for round belt drives, such as the female threaded shaft

Grooves can impair the concentric precision of conveyor rollers. Interroll recommends conveyor rollers with round belt heads or PolyVee drive heads of the Fixed Drive Conveyor Roller Series 3500 to ensure that concentric precision is adhered to (p 211).

Please refer to p 43 for the standard positions of the grooves on the tube.

BEARING

A number of different bearings are available for many Interroll conveyor rollers. The following section only describes the precision ball bearings used by Interroll.

Further information on the bearing assemblies (ball bearings with bearing housings and seals) is provided in the Platforms chapter (p 176) and in the Material Specification in the Bearings chapter (p 227).

All of the precision ball bearings, with the exception of type 689, are manufactured in 2RZ:

The steel sealing discs form a narrow sealing gap and make no contact, thus ensuring that the rollers start up perfectly. The steel-reinforced rubber sealing lips (NBR) lie against the inner ring under external pressure and thus provide an exceptional sealing quality comparable to the 2RS version.

The oil-lubricated version is characterised by its easy start and exceptional easy-running properties.

DIN 625-Compliant Precision Ball Bearings

- Series 60 and 62 standard DIN grooved ball bearings
- Excellent load capacity and operational life
- Precision ball race
- Extremely temperature-resistant
- Low-noise operation

All precision ball bearings are specified by Interroll beyond the requirements of DIN 625 for optimum, durable and absolutely constant operation. Interroll specifies the bearing play, lubrication and sealing etc.

Precision ball bearings, lubricated (6002 2RZ, 6003 2RZ, 6204 2RZ, 6205 2RZ, 689 2Z)

Material	Rings and balls are made of stainless steel of material grade 100Cr6 Hardness: 61 ± 2 HRC, with metal cages
Bearing play	C3
2RZ Seal	Non-grinding 2-lip seal with labyrinth effect manufactured from steel-reinforced acrylonitrile-butadiene rubber (NBR)
2Z Seal	Non-grinding cover discs made of sheet steel
Lubrication	Multi-grade grease, silicon-free
Temperature range	-30 °C to +177 °C

Precision ball bearing, lubricated (6002 2RZ)

Material	Rings and balls are made of stainless steel of material grade 100Cr6 Hardness: 61 ± 2 HRC, with metal cages
Bearing play	C3
2RZ Seal	Non-grinding 2-lip seal with labyrinth effect manufactured from steel-reinforced acrylonitrile-butadiene rubber (NBR)
Lubrication	Multi-grade oil, silicon-free
Temperature range	-30 °C to +80 °C

DIN 625-Compliant Precision Stainless Steel Ball Bearings

- Design and load capacity as per the DIN 625-compliant precision ball bearings
- Manufactured throughout from corrosion-proof material
- Type 6002 2RZ always available

Precision ball bearings made of stainless steel (6002 2RZ)

Material	Rings and ball made of stainless steel, material 1.4125 (X105CrMo17), with a material grade to comply with AISI 440C Hardness: 56 ± 2 HRC, with polyamide cages
Bearing play	C3
2RZ Seal	Non-grinding 2-lip seal with labyrinth effect manufactured from steel-reinforced acrylonitrile-butadiene rubber (NBR)
Lubrication	Multi-grade grease, silicon-free
Temperature range	-30 °C to +177 °C

DRIVES

A differentiation is made with drives between the medium and the type of power transmission.

Interroll offers the following as the medium of power transmission:

- Chain
- Toothed belt
- PolyVee belt (multi-rib belt)
- Round belt
- Flat belt

Interroll offers the 24 V DC RollerDrive as a motorised drive integrated within the conveyor roller.

In principle, there are two possible types of power transmission:

- **Tangential:** Via a chain running along the side of the conveyor
- **Roller-to-roller:** Roller-to-roller

Both types can be designed as friction and fixed drives.

The following section describes the drives and their properties.

Drive Selection for Conveyor Rollers

Chain The chain is a tried and trusted method for driving conveyor rollers and conveyor elements in conveyor technology. Chains are characterised by their robustness and durability and are not sensitive to dirt and environmental influences. Very high levels of power can be transmitted with a chain.

Chains are not maintenance-free and are relatively loud in operation. They must be lubricated regularly in order to achieve an optimum service life. Speeds of more than 0.5 m/s are not recommended due to the seriously increasing noise level.

Tangential drive

The tangential chain drive is characterised by its good level of efficiency and simple design.

The installation length of the conveyor roller is shorter than for a roller-to-roller drive, as the drive head consists solely of a sprocket. A single chain drives all of the rollers in a conveyor. The chain is guided extremely precisely to the sprockets by a chain guide profile made of special plastic.

The sprockets are mounted in a fixed manner on the conveyor rollers. The teeth of the sprockets mesh into the chain and only transfer the driving power required for the individual roller. The chain can be guided either along the top or bottom of the conveyor rollers. The precise positioning of the chain guide in relation to the conveyor rollers is extremely important. The maximum play in terms of height is 0.5 mm.

The motor station to be driven is installed in such a way that the driving side of the chain is as short as possible. It is advisable to provide the motor station with additional equipment for adjusting the chain tension. Return rollers, which have to carry not only the load of the material to be transported, but also the chain traction forces, must be

checked specifically with regard to their permissible bearing load. The driven conveyor length is restricted by the permissible breaking load of the chain or by the weight of the material to be transported.

The roller spacing (roller pitch) can be selected as required with tangential drives. Compared with roller-to-roller drives, the conveyor rollers are easy to fit and remove with tangential drives.

Roller-to-roller drive

With this type of drive, every conveyor roller is connected to the next one by a chain. The conveyor rollers thus require drive heads with two sprockets, which require greater meshing protection than with tangential drives.

No chain guide is required. The roller spacing (pitch) is subject to tight tolerances, as the spacing depends on the pitch of the chain. The maximum conveyor length that can be driven by one motor station is limited by the permissible breaking load of the chain. The chain is subjected to its maximum load at the motor station. The tolerances for the conveyor roller pitch t and the breaking loads are shown in the following table.

Chain pitch "	P mm	Tolerance for t mm	Breaking load N
3/8	9.52	0 to -0.4	9,100
1/2	12.70	0 to -0.5	18,200
5/8	15.88	0 to -0.7	22,700
3/4	19.05	0 to -0.8	29,500
1	25.40	0 to -1.0	58,000

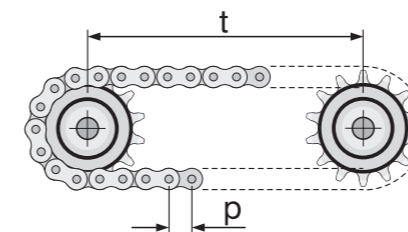

In order to keep the chain forces as low as possible, the drive station must be positioned in the middle of the conveyor length. When designing the drive station, it is essential to ensure that the sprockets have at least a 180° deflection and that the chain can be retensioned.

DRIVES

Toothed belt The toothed belt is maintenance-free and runs very quietly. No lubrication and retensioning is required.

However, the profile pitch has to be very precise as the meshing is form-fit with the profile of the drive head. Otherwise the service life of the toothed belt will be dramatically reduced. The tolerances for the holes differ immensely among the toothed belt manufacturers. Interroll therefore recommends obtaining precise tolerances from the manufacturers.

The toothed belt is only used infrequently in container conveyor technology as its efficiency is relatively poor, due to the construction of the belt, and a large proportion of the driving power is used by the belt. Toothed belt drives are primarily used in the conveyance of pallets or in the automotive industry for the transportation of special carriers. The poor efficiency of the belt in relation to the total drive power is relatively immaterial in these instances.

The toothed belt is fundamentally unable to negotiate curves.

Tangential drive

Tangentially the toothed belt should only be used for relatively low levels of power. It is essential to ensure that a special guide presses the belt securely onto the drive head. When used tangentially, the level of efficiency of the toothed belt is significantly higher than when used in roller-to-roller applications.

Roller-to-roller drive

Toothed belts are primarily used with roller-to-roller drives. High torque can be achieved at high speed with these drives. The disadvantage with these drives is their susceptibility to dirt and the essential requirement relating to the precision of the hole in the side profile.

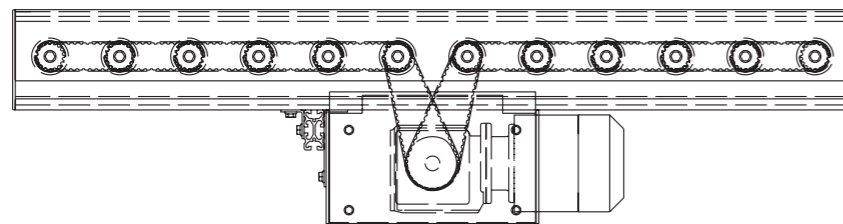

Only PolyVee belts with flexible traction carriers may be used in conveyors. These belts are sufficiently flexible and simplify installation. The flexibility of the traction carrier makes it possible to overcome hole tolerances in the side profile and to use the PolyVee belt in curves.

PolyVee belts offer significant benefits over round belts. With up to 300 % higher torque transmission, the drive power is transmitted evenly to all conveyor rollers. This means that shorter acceleration and braking paths are possible.

PolyVee belts also permit reliable accumulation in curves. Thanks to the belt's outstanding torque transmission, the material to be transported start up again, irrespective of whether or not they have come to a standstill on a drive.

The PolyVee belt works in the same way on rising and falling conveyors. Here the even torque transmission to all conveyor rollers is especially important with the result that the material to be transported retains as large a driven contact area as possible. Reliable conveyors can be constructed in conjunction with PVC sleeve-covered tubes.

Thanks to its particularly compact design, the PolyVee head enables the torque transmission to be positioned very close to the profile. This leaves more room for the materials to be transported with the same overall width of conveyor. As the belts do not come into contact with the material to be transported, even very lightweight materials to be transported are not displaced but always run perpendicular to the conveyor rollers.

- Flexible standard belts, pre-tension 1 to 3 %
- PJ form; ISO 9982; DIN 7867; Pitch 2.34 mm
- Belts with up to 4 ribs can be used (2 x 4 ribs + 1 distance groove)

The PolyVee belt is fundamentally only used in conveyors with roller-to-roller drives, as no useful torque transmission can be achieved tangentially.

Roller-to-roller drive

Owing to the higher pre-tension of the PolyVee belt compared with round belts, Interroll recommends the use of an assembly tool to install the conveyor rollers.

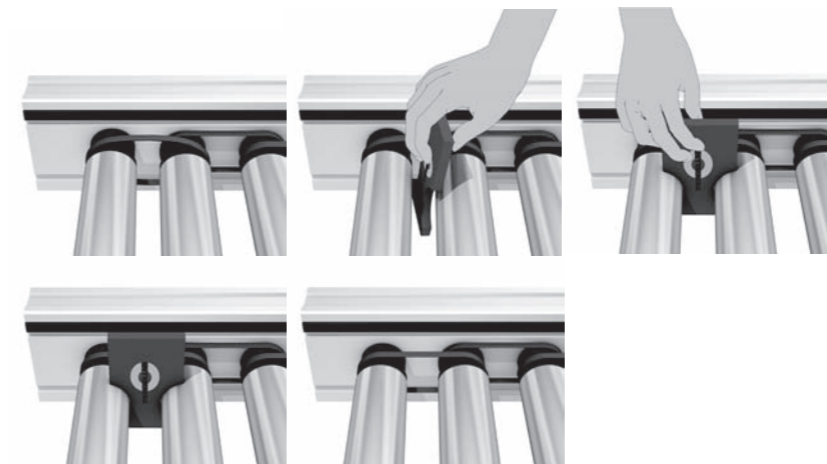

DRIVES

The assembly tool considerably simplifies the installation of the belt as the correct distance of the conveyor rollers can be adjusted by hand.

Owing to the serious conveyor force of PolyVee belts, they have to be protected against interference from outside, e. g. by covering or sealing the gap between the conveyor rollers.

Two versions of PolyVee belts are primarily used:

- Two-ribbed PolyVee belts for the conveyance of materials to be transported under 50 kg and at speeds of 0.6 to 2 m/s. The maximum number of idlers is 20. The material to be transported can also come to a stop on the idlers.
- Three-ribbed PolyVee belts are used for heavy materials to be transported. Three-ribbed belts fully use the drive power and are also suitable for long conveyors and for inclined sections.

With PolyVee conveyors with more than 15 conveyor rollers, there is a reduction in speed of one revolution per minute with each conveyor roller. There are geometric reasons for this: Owing to the displacement of the neutral fibres in the PolyVee belt, there is a kind of translation from roller to roller under pressure. The reduction in speed is due to the system and is not accompanied by an increase in wear and tear.

Round belt

The round belt is a widely-used method of torque transmission in conveyors. It is characterised by simple handling during installation and low costs. The disadvantage of these belts is their poor power transmission and relatively short operational lifespan.

There are two available versions of roller-to-roller round belts:

- Roller-to-roller
- With driveshaft

Tangential drive

The conveyor rollers do not need drive elements when used on straight conveyors. The round belt then runs on the smooth tube. Gravity makes the conveyor rollers lie on the belt, which displaces them in a rotational movement.

The power transmission is relatively poor. A tensioning element must be provided at the motor station.

Thanks to their symmetrical cross-section, round belts are also ideal as a drive for curves. Then return rollers have to be fitted, which reliably link and return the round belt to all of the conveyor rollers.

Roller-to-roller drive

This is one of the most common uses of round belts. One round belt always connects two conveyor rollers. It usually runs in round grooves in the roller. Installation is simple and requires no additional tools. When installing a conveyor, it is essential to ensure that the material to be transported always has direct contact with a drive roller, e. g. a RollerDrive.



Roller-to-roller drive with driveshaft

This is also a very common use of round belts. In this case, the entire conveyor is moved by a driveshaft running at right angles underneath the conveyor track. Special wheels are fitted on the drive shaft. The wheels drive all of the conveyor rollers with round belts, which are turned at 90°. Every conveyor roller generally only has one round groove. The wheels can either be fixed or sit loosely on the driveshaft.

A loose connection produces a low pressure accumulation conveyor. It must be ensured that the round belt never slips through as this could significantly shorten its service life. For this reason the wheels should not be fixed to a driveshaft on an accumulation conveyor.

Flat belts are commonly used as a drive for roller conveyors, as they have a simple design and require very little maintenance.

A roller-to-roller drive with a flat belt is not sensible.

Tangential drive

The flat belt runs underneath the roller conveyor and is pressed against the rollers by pressure rollers. The pressure rollers are positioned at a spacing of at most four conveyor rollers. The pressure rollers also return the flat belt.

On accumulation conveyors, the height of the pressure rollers has to be adjusted extremely precisely so that the flat belt can slip past the pressure roller, without causing above-average wear and tear.

The flat belt must be pre-tensioned by a tensioning device to approx. 1 %. The belt is generally driven by an AC gear motor, located underneath the roller conveyor.

The drive power is in many cases transmitted more reliably if the loop angle of the flat belt on the drive drum on the AC gear motor can be increased with narrowing wheels.

The conveyor rollers require no special drive heads and smooth tubes can be used.

Flat belt

DRIVES

RollerDrive drive selection

The RollerDrive is are often used on zero pressure accumulation conveyors.

The principle of ZPA (Zero Pressure Accumulation) conveyors is based on the segmentation of the conveyor into zones. The zone length is determined by the length of the package to be conveyed plus its run-on. One zone essentially comprises a RollerDrive, a sensor, idlers (rollers without their own drive), torque transmission belt and a controller.

A typical ZPA conveyor consists of a number of zones, such as this, which communicate with each other by means of ZoneControls, and ensure that only a minimal number of RollerDrive are in operation, or as many as are needed to transport the material to be conveyed.

This zonal principle thus differs fundamentally from conventionally driven conveyors, on which the central drive is running constantly, thus creating substantial energy consumption. The ZPA principle guarantees excellent availability of the materials to be conveyed at the discharge point. It is primarily used where the feed frequency runs asynchronously to the picking frequency of the material to be conveyed on the conveyors. The ZPA principle thus acts as a buffer.

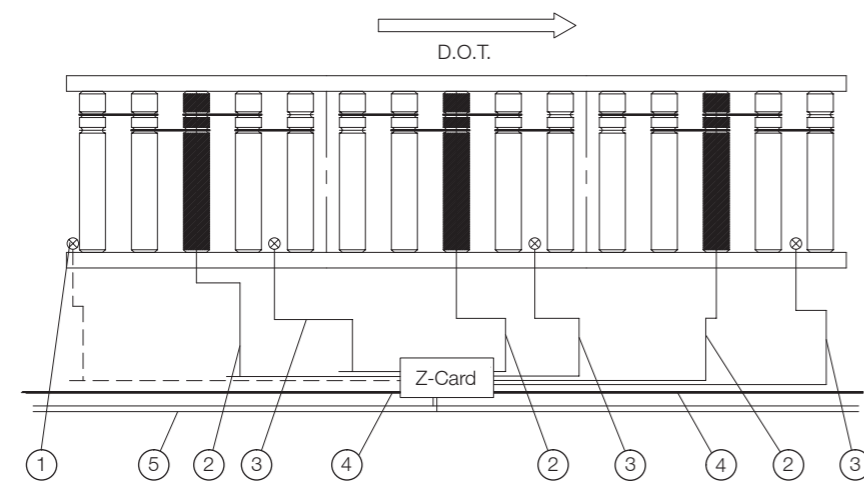

- 1 Start photo cell (optional)
- 2 RollerDrive connection
- 3 Photo cell connection
- 4 Communication cable (Easy-Bus)
- 5 24 V bus system

The following diagrams show two examples of zone control.

In **individual pull-off mode**, a control PCB communicates with an upstream and a downstream zone.

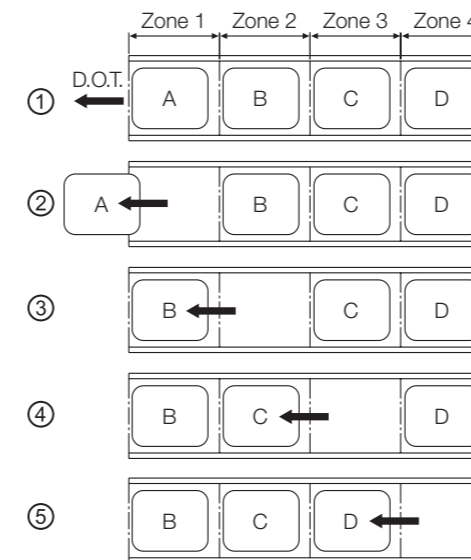

- 1 Zone 1 receives a start signal.
- 2 Container A leaves the conveyor segment.
- 3 Zone 2 receives a start signal from Zone 1. Container B moves to Zone 1.
- 4 Zone 3 receives a start signal from Zone 2. Container C moves to Zone 2.
- 5 Zone 4 receives a start signal from Zone 3. Container D moves to Zone 3.

DRIVES

In **block pull-off mode**, a control PCB can receive a start/accumulation signal from the furthest away downstream zone and then gives a start/accumulation signal to the furthest away upstream zone. The following example shows zone 1 in individual pull-off mode.

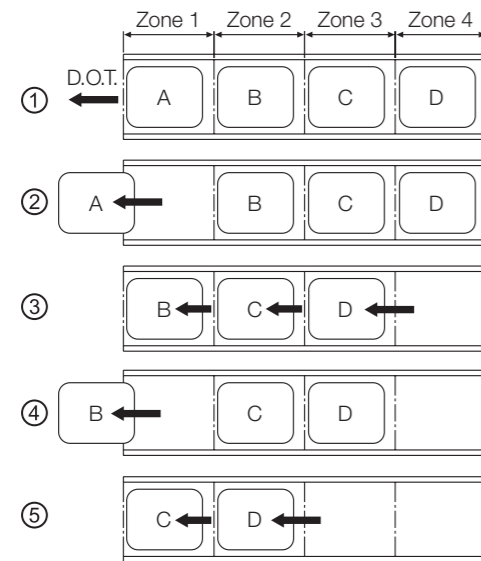

- 1 Zone 1 receives a start signal.
- 2 Container A leaves the conveyor segment.
- 3 Zone 1 gives a start signal to the upstream zones 2, 3 and 4. Containers B, C and D move forwards.
- 4 Zone 1 receives a start signal and container B leaves the roller conveyor section.
- 5 Zone 1 gives a start signal to the upstream zones 2, 3 and 4. Containers C and D move forwards.

RollerDrive BT100

With a continuous power output of 11 W, the BT100 represents the first unit in the RollerDrive range. It is the optimum solution for applications with lower throughputs. Due to the simplicity of its control, the BT100 can be integrated simply and easily into the most diverse schemes.

No special controller with current limitation is needed. With an operational lifetime of 6,000 hours, the BT100 can convey up to 14 million items over an average zone length. Operating at a noise level of 47 dB(A), the BT100 is the quietest RollerDrive. This is achieved by means of a single- and two-stage helical polymer gear box and decoupling.

The RollerDrive BT100 is widely used for returning empty containers, accumulation sections, buffer sections and for supply for order picking. Many IP66-compliant applications can also be achieved. Owing to its very low noise level, the BT100 is ideally suited for applications in assembly plants, where the automated conveyor is often the only moving mechanism.

The RollerDrive EC310 is the best choice for a wide range of applications. The product portfolio has been significantly shored up in the electronically commutated sector to provide a product and control range for practically all applications. With a mechanical output of 32 watts and new and different gear stages, it is now possible to coordinate the drive perfectly with the application.

Energy recovery is the key to optimising the motor. When the EC310 switches to braking mode, this means that there is no longer a driving signal at the drive so that the movement energy of the materials being conveyed is converted into electrical current. This is then returned to the DC mains and is again available to other RollerDrive and consumers. With all RollerDrive models to date, the motor winding is used as braking resistance and thus the movement energy of the materials being conveyed are purely converted into heat in the motor. This results in the thermal balance of a drive such as this being additionally impacted by the braking. It has been possible with the EC310 to remove this energy from the drive and reuse it. Under the best conditions in cyclical operation, this provides an energy saving of approx. 30%.

At the same time the drive heats up considerably less. The braking and acceleration power of the RollerDrive EC310 is also significantly superior to other 24 V drives. In order to prevent harmfully high voltage building up in the DC mains and thereby possibly damaging other connected components, all Interroll controls (DriveControl 20, DriveControl 54 and ZoneControl) include brake choppers. A brake chopper is a voltage-switched load resistance that is activated when a DC bus voltage of 27 V is exceeded and prevent the voltage from rising above 30 V. In the majority of applications, the chopper does not become active as there are several consumers on a power unit and the energy that is fed back is absorbed and does not lead to an increase in voltage in the DC mains.

DRIVES

Fixed drive

The fixed drive is characterised by a form-fit and force-fit connection between the drive head and the load-bearing tube. There is no friction, the drive torque is fully transmitted. Slippage within the power transmission is not anticipated.

Friction drive

The friction drive is based on the principle of the slip coupling. It offers the option of setting up an accumulation conveyor very cost-effectively with minimal accumulation pressure.

The construction thus requires very few drives, with segmentation being provided by mechanical stoppers. The bearing housing of the Series 3800 is designed as a greased-for-life slip coupling and thus guarantees the roller's constant conveyor force. The tangential chain drive has proved itself to be especially economical when used on friction conveyors. A central drive drives a long chain underneath the conveyor so that all of the rollers are operated.

If an accumulation should occur, then the rollers under the material to be transported stand still and only the drive heads continue to rotate. It should be noted that the accumulation pressure is cumulative with the length of the accumulated material to be transported. In this way the containers are able to absorb the accumulation pressure without becoming deformed. The design should also prevent the containers from being prised out owing to the increasing accumulation pressure. The friction drive is available for straight conveyor segments and also for curves.

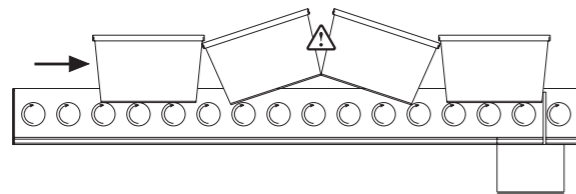

Conveyor force of the friction drive

The conveyor force produced by friction by the friction roller regulates itself relative to the weight of the material to be transported. The conveyor force is seriously affected by the following factors:

- Weight of the material to be transported
- Condition of the base of the material to be transported
- Humidity
- Temperature
- Percentage of accumulation mode over the entire running time

These factors have, to an extent, a considerable effect on the operation and operational lifespan of the conveyor roller. Accumulation mode should only be used for as long as is necessary. When it can be seen that no conveyance will take place, then the central drive should be switched off. No energy will be used and the lifespan of the conveyor system will be increased. We would recommend discussing your individual application with Interroll experts and also conducting an operational test with the original materials to be transported.

The following conveyor values are non-binding and relate to a normal environment (65 % relative air humidity and a temperature of +20 °C) and to the material to be transported sitting centrally on the conveyor rollers. The figures will be markedly different if the load centre is not central. The figures will fall the further the load centre is from the drive element. Even and stable bases of the materials to be transported are ideal so that each roller carries the material evenly.

The following conveyor power is produced depending on the roller load:

- 4 to 6 % with one-sided friction coupling and Ø conveyor roller 50 mm
- 2 to 5 % with one-sided friction coupling and Ø conveyor roller 60 mm
- 8 to 13 % with two-sided friction coupling and Ø conveyor roller 50 or 60 mm
- 4 to 6 % with load-dependent conveyance, adjustable up to approx. 12 % of the roller load by additional axially adjustable friction coupling

The permissible conveyor speed is 0.5 m/s. Flanges and other side guides are not recommended with friction rollers as the static friction produced may not be overcome by the conveyor force of the friction coupling.

Accumulation in curves with friction rollers should always be avoided. If accumulation is to occur in curves, then only zero pressure accumulation systems, such as RollerDrive can be employed.

SHAFTS

All Interroll uncoated steel and zinc-plated shafts are manufactured from cold drawn steel.

Zinc-plated shafts are cut from galvanized zinc-plated rod material, thus the front faces of the female threaded or spring-loaded shafts are always without zinc plating. Zinc plated male threaded or flatted shafts with a diameter of 17 mm or more are only zinc-plated as a component after machining. Male threaded or flatted shafts with smaller shaft cross-sections are not zinc-plated but rather manufactured from stainless steel.

All shafts are sawn and milled to ensure that the shaft ends are perfect. This avoid problems when fitting the shafts or from deformed shaft ends caused by trimming the shafts with cutters.

With threaded holes, the centring holes are drilled in a first step to ensure the precise centring of the threaded hole in the shaft.

Frame Profiles, Hole Dimensions and Shaft Selection

The following should be considered in relation to the selection of a shaft and construction of the frame profiles:

- The hole dimension of the frame profile should be as small as possible on rollers with female threaded shafts to minimise the height difference of the conveyor rollers. This enhances the operation of the roller conveyor.
- With aluminium profiles, female threaded shafts with as large a diameter as possible and as small a thread as possible should be selected. This minimises the risk of the shaft penetrating the aluminium profile.
- On conveyor rollers with spring-loaded shafts, it must be ensured when drilling the profile hole that the conveyor rollers will, by necessity, have to be fitted diagonally. Too small a hole could make installation significantly more difficult.

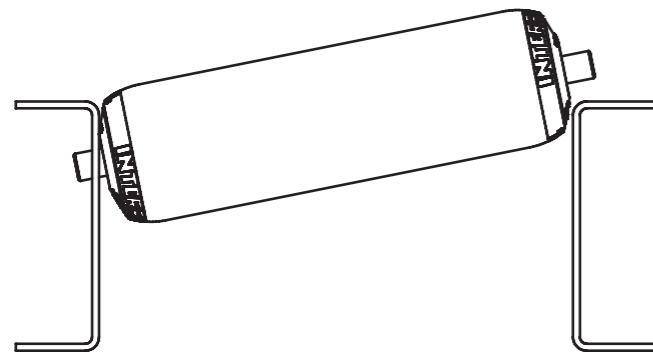

Standard Shaft Versions



Conveyor rollers with spring-loaded shafts are the simplest version of shaft and are extremely quick to fit and remove. Suitable crosslinks have to be provided between the frame profiles to reinforce the conveyor.



Compared with spring-loaded shafts, female threaded shafts have a very stable frame construction and are significantly quieter than loosely assembled conveyor rollers. The roller shafts and profiles stabilise each other resulting in the conveyor rollers having a greater load capacity than loosely fitted rollers. These shafts take longer to fit and remove than spring-loaded shafts.

Spring-loaded
shaft

Female
threaded shaft

SHAFTS

Shafts with
shaft shuttle



The spring-loaded, tapered shaft shuttle combines the advantages of spring-loaded and female threaded shafts: quick to fit and a very low noise level.

The shaft shuttle permits the roller to be fitted free of play into conveyor profiles with 11 mm (+0.3 / 0.8 mm) hexagonal holes. The maximum reference length is 1,000 mm and the maximum load capacity is 350 N.

- Fits free of play, without wear and tear, in the profile (as with female threaded shafts)
- Minimal installation (as with spring-loaded shafts)
- Exceptionally low-noise operation
- Conductive material to discharge static charges
- Counter-aligned shuttles
- Both shafts ends are pressed in

Further Shaft Versions



Flatted shafts have lateral, parallel milled sections at the shaft ends, which fit into corresponding profiles, for example into profiles with open longitudinal holes. They are therefore quicker to fit and remove but provide less stability than threaded shafts.

If corrosion protection is required, male threaded shafts and flatted shafts up to a diameter of 14 mm can be manufactured throughout from stainless steel material. The alternative to this would be piece zinc-plating following mechanical machining to provide complete corrosion protection for the shaft. Interroll provides this alternative with shafts above a diameter of 17 mm.

The following shaft versions for platforms 1100, 1200 and 1700 can be supplied with an extended shaft projection:

- Spring-loaded shaft
- Female threaded shaft
- Male threaded shaft
- Flatted shaft

Axial support by the seal can no longer be guaranteed with a variable shaft projection. With greater axial forces, for example where there is lateral displacement, suitable replacement structures, such as spacing tubes, may possibly have to be fitted.

Male threaded
and flatted
shafts

Shaft
extensions

SHAFTS

Shaft adapter

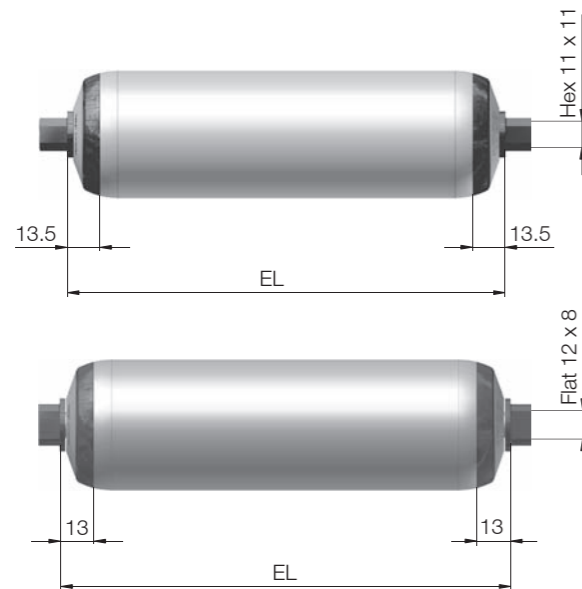

Shaft adapters reduce the noise level, especially with platform 1100 and 1700 conveyor rollers. The adapters have a joint, by means of which the installation length can be increased. Shaft adapters are suitable for rigid shafts in conjunction with profiles with open longitudinal holes. With these profiles, the conveyor rollers are laid in loosely from above. Interroll provides polymer adapters made of POM, which are designed to be conductive and thus prevent electrostatic charges.

Adapter version for a shaft with diameter	For profile holes
8 mm	11 mm hex
10 mm	Flat 12 x 8

The differential dimension of the installation length (installation length (EL) to reference length (RL)) increases by 5 mm for an 8 mm shaft, and by 4 mm for a 10 mm shaft.

Shaft adapters are not a substitute for shaft shuttles.

Axial Play

Axial play must be taken into consideration when fitting conveyor rollers so that the conveyor rollers can only move a minimal amount in an axial direction when under tension.

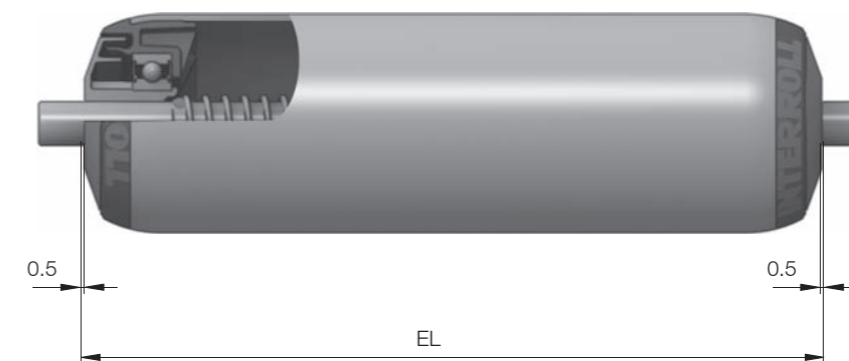

Interroll recommends a total axial play of 0.5 mm per roller side. This dimension has already been taken into account in calculating the reference length/ordering length.

With conveyor rollers with female threaded shafts, axial play is produced by the shaft projection towards the body of the roller.

The axial play stated by Interroll is only a guideline figure. There may be slight deviations from this figure in individual cases when production tolerances are added. Interroll guarantees the axial play and thus the operation of a correctly fitted and operated conveyor roller is not impaired.

STRAIGHT CONVEYOR SECTIONS

Determining the Number of Conveyor Rollers

The number of conveyor rollers required is calculated from the total length of the conveyor section, divided by the pitch + 1. The pitch is the spacing between two conveyor rollers.

The pitch is determined by the length and type of materials to be transported and the load capacity of the conveyor rollers.

In principle at least three rollers must always sit under the material to be transported in order to ensure that it is conveyed smoothly. The pitch should therefore be at most one third of the length of the shortest material to be transported.

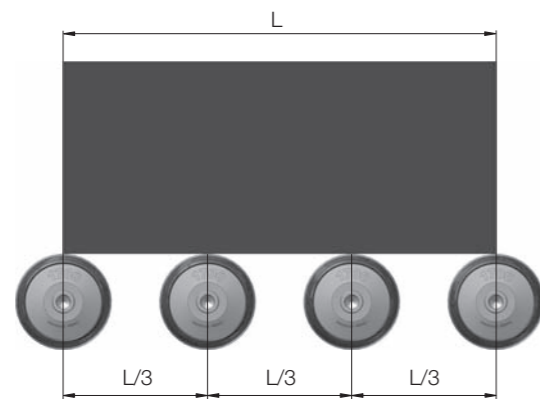

This rule of thumb only applies to the conveyance of materials to be transported with flat bases and to rollers with adequate load capacity. When pallets are to be conveyed, for example, the load is only carried by around 1/3 to 2/3 of the conveyor rollers underneath the pallet, owing to the properties of the pallet.

It is therefore necessary to check whether the load capacity of the conveyor rollers is adequate, taking into consideration the pitch and the properties of the materials to be transported (cf. Planning Basics p 172). A narrower pitch or conveyor rollers with a higher load capacity may possibly have to be opted for.

All other decisions relating to the choice of the optimum pitch are the responsibility of the plant constructor and can possibly only be answered by conducting tests.

Determining the Load of the Conveyor Rollers

The load capacity of the conveyor rollers depends on the load capacity of the roller assemblies - tube, shaft and bearing.

The load capacity of the weakest assembly in each case determines the load capacity of the entire conveyor roller. The individual assemblies are compared in terms of their load capacity and calculated together to determine the load capacity of the conveyor roller.

The load capacity of the roller is decisively affected by its length, load distribution and shaft fixing.

The permissible load figures for conveyor rollers can be found in the corresponding tables on the product pages or alternatively calculated using the Interroll roller calculation program:

www.interroll.com/roller_calculation/

The load capacity of driven conveyor rollers is often limited by other load limits, e.g. by the permissible loading on the drive chain and other drive elements or by the torque of the drive motor.

The maximum load capacity of a tube depends on two conditions:

- The flexural stress of the tube must be below the permitted material limit value
- The maximum deflection of the tube should not exceed 0.1 % of the installed length.

The flexural stress and deflection can be calculated using the following formulae:

$$\text{Flexural stress } \sigma = M_b/W = F \cdot EL/(8 \cdot W)$$

$$\text{Deflection } f_t = 5 \cdot F \cdot EL^3/(384 \cdot E \cdot I)$$

M_b	Bending torque
W	Section modulus
F	Load
EL	Installation length
E	Modulus of elasticity
I	Moment of inertia

The formulae and information on the load capacity relate to an even distribution of the load on the surface of the tube. Concentrated or even point loading must be taken into special consideration when selecting the tube.

**Maximum load
capacity of the
tube**

STRAIGHT CONVEYOR SECTIONS

Maximum load capacity of the shaft

The maximum load capacity of a shaft depends on two conditions:

- The flexural stress of the shaft must be below the permitted material limit values
- The deflection of the shaft must be below the permitted material limit value

The figures on load capacity only differentiate between two shaft versions: shafts positioned loosely in the frame profile (e. g. spring-loaded shafts) and shafts threaded into the frame profile (e. g. female threaded shafts).

The figures on the load capacity of threaded shafts do not take into account any possible deflection of the frame profile or the side flanges. Should there be deflection, this will impair the load capacity of the shafts.

Maximum load capacity of the bearing assembly

The load capacity of the bearing assembly takes into account the ball bearing, bearing housing and the seal/end cap. The limit values are determined empirically and are only achieved with very short conveyor rollers.

Concentric Precision of the Conveyor Rollers

Interroll manufactures conveyor rollers from tubes which comply with the DIN standard. This standard permits deviations in concentric precision.

The concentric deviation is the maximum radial deviation of the diameter of the tube from a perfect circle. Thus, for example, a concentric deviation of $t = 0.3$ mm means that the maximum radial deviation is 0.3 mm over the entire tube.

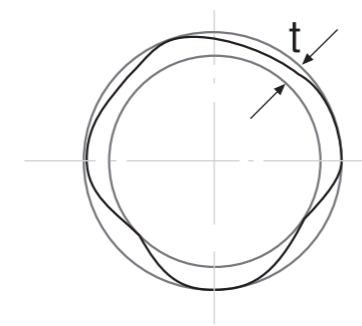

Fig.: Concentric deviation (t)

Concentric deviation depends first and foremost on the length and material of the tube. It is all the greater the longer a tube is, especially with polymer tubes.

The following section outlines the concentric deviations for complete conveyor rollers for the different tube materials. The graphs show the average concentric deviation according to the tube length for a certain tube diameter.

Please note that DIN-compliant tubes are permitted significantly higher concentric tolerances than are shown in the following diagrams. For this reason, the guideline values presented can be exceeded in individual cases.

STRAIGHT CONVEYOR SECTIONS

Steel tubes

Concentric deviation in mm

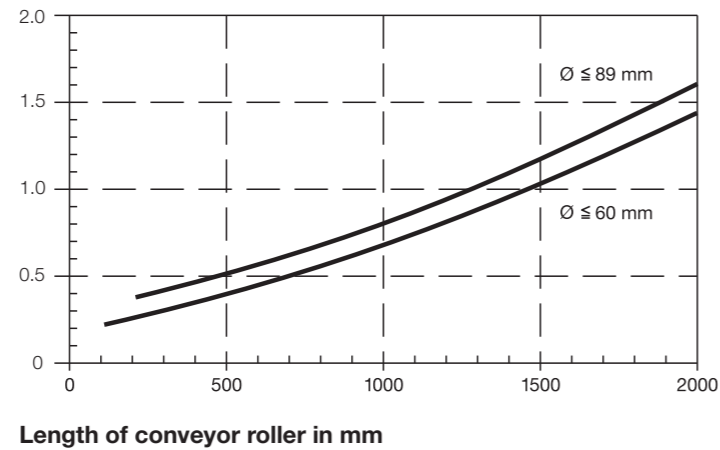

Polymer tubes

With polymer tubes the concentric deviation increases disproportionately to the length of the tube.

The following lengths should not be exceeded:

Tube diameter mm	Maximum tube length mm
20	400
30	500
40/50	600
63	800
90	1,000

Concentric deviation in mm

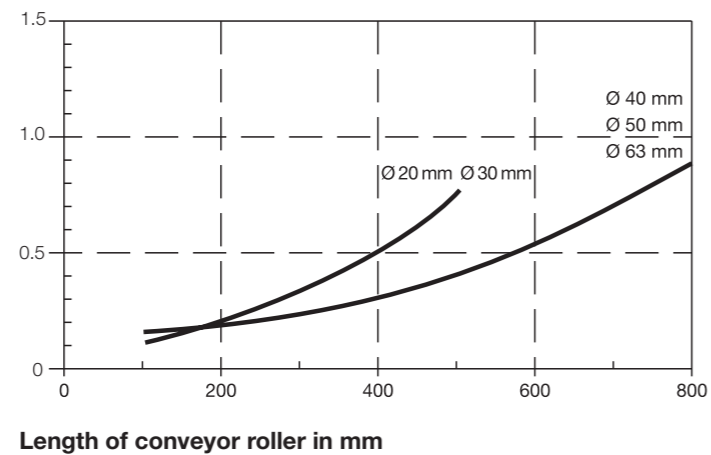

Length Dimensions of Conveyor Rollers

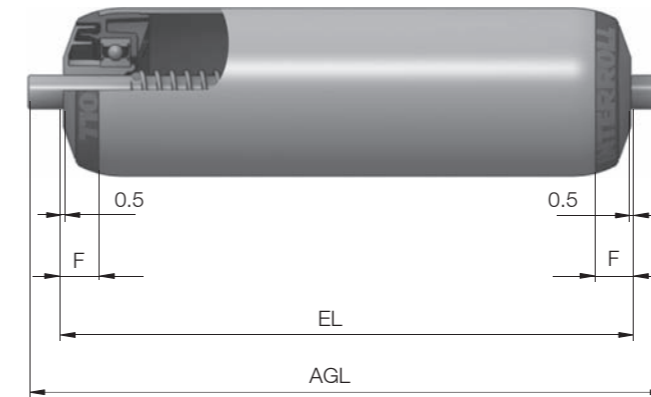

EL	Installation length: The clearance between the side profiles
AGL	Total length of shaft
F	Length of the bearing assembly, including axial play

The total shaft length corresponds to the installation length with female threaded shaft rollers.

The installation length can only be measured on the conveyor roller with female threaded shafts, as then EL is at one and the same time the length of the shaft. With all other shaft versions, the EL cannot be measured on the conveyor roller as an axial play of 0.5 mm has to be taken into account for each side of the roller.

The reference length/ordering length RL does not have any reference points on the conveyor roller for the following Series: 1100, 1700, 1700 light, 1700KXO, 3500, 3500 light, 3500KXO, 3560, 3800, 3860 and 3870. RL cannot be shown in the dimensional drawing but can be taken from the table of dimensions on the respective product page.

MAGNETIC SPEED CONTROLLER 50

General Description The Magnetic Speed Controller 50 is a purely mechanical speed controller that ensures a controlled, slow speed on gravity conveyors with materials weighing from 0.5 kg to a maximum of 35 kg. The magnetic speed controller operates without a gear box, thus enabling startup for very lightweight containers. The maximum mechanical output is 28 W for the range of the RollerDrive EC 310, thus providing the required consistently high braking power for heavy containers. The operating principle is an eddy current brake; double shielding of the magnets enables a uniform braking action.

Planning and assembly The central hexagonal shaft provides torque support in the frame profile. The optimal solution is therefore a form-fit installation of the hexagonal shaft in a correspondingly shaped hole. In order to ensure reliable support when installing a female thread shaft, a minimum torque of 20 Nm must be applied. The use of a screw locking device is strongly recommended.

The speed controller is manufactured with a tube diameter of 51 mm. Together with Ø 50 mm conveyor rollers, this creates a minimum higher surface of 0.5 mm in order to obtain secure contact with the material. The higher surface of 0.5 mm to the conveyor rollers is ideal in order to ensure reliable braking.

The pitch, number and version of the MSC 50 in a roller conveyor depends on many parameters, such as the gradient, infeed speed, weight and container types. The following values were determined by Interroll using numerous tests with idealized containers with respect to the running side and provide an initial point of reference for a base calculation/basic layout. As the combination of critical parameters is infinite, we recommend that you determine the final layout empirically, if necessary. For this reason, no specific data about the conveying speed can be provided. Lightweight containers travel very slowly with approx. 0.01 m/s; heavy containers can be decelerated to a speed of approx. 0.5 m/s under optimal conditions.

The design with a PU sleeve is used for improved static friction of smooth plastic containers in combination with steep gradients and high weights. Cardboard boxes and other materials have sufficient adhesion for the zinc-plated steel tube with Ø 51 mm. Gradients from 5 % to 10 % were analyzed during the numerous lab tests and beta tests. The following distances between the MSC 50s were tested successfully:

- Maximum distance of 2,000 mm for weights of up to 10 kg
- Distance of 800 mm–1,500 mm for weights of up to 20 kg
- Up to 35 kg, the distance is matched to the container length

When infeed speeds into the gravity conveyor are greater than 1 m/s, we recommend a single installation of three to four MSC 50s over a length of approx. 1,000 mm in order to obtain a maximum reduction of the infeed speed immediately. The distance values listed above can then be applied.

CURVES

Tapered conveyor rollers convey materials to be transported safely in curves. With tapered conveyor rollers, the conveyor speed increases according to the radius of the curve so that the materials to be transported maintain their alignment between the side profiles. Side guides are recommended but are not imperative.

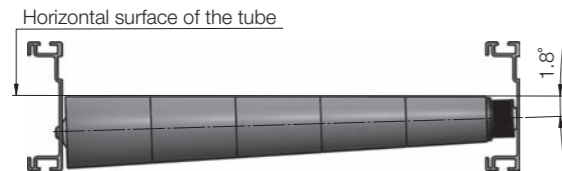

When designing the curve it is essential to ensure that the tube surface of the tapered elements is horizontal. The shaft of the conveyor roller is inclined by 1.8°.

**Series 1700KXO/
3500KXO with an
internal
radius of 650 mm**

Interroll's Tapered Conveyor Rollers are suitable for use with curve internal radii of 800/850 mm/770/820 mm where the drive head is on the internal radius.

Platform 1700 Tapered Conveyor Rollers can also be used for an internal curve radius of 650 mm.

Should the specified internal curve radii not be adhered to then the user has to count on the materials not being conveyed smoothly.

The actual clearance of the conveyor should be approx. 50 mm greater than the calculated width to ensure smooth conveyance of the materials around curves. Please select the next higher standard installation length.

Interroll offers two types of Tapered Conveyor Roller, which are both designated as KXO. The first roller is based on the Series 1700 Universal Conveyor Roller and the second on the Series 3500 Fixed Drive Conveyor Roller.

**Tapered Universal
Conveyor Roller
Series 1700KXO/
3500KXO**

- Tapered polymer tube sleeves:
 - Abrasion-proof
 - Sound reduction
 - Impact-resistant
 - Weather- and temperature-resistant
- Lightweight, hence good running and starting properties
- End cap for tapered elements on the side with the largest diameter
- Load capacity 500 N

Tapered Conveyor Roller Versions

Tapered conveyor rollers with curved internal radii of 800/850 mm are available in the following versions and materials:

Version	
Reference length	From 250 to 900 mm in increments of 50 mm
Shaft	Female threaded shaft (M8 x 15)
Shaft diameter	12 or 14 mm
Bearing	Precision ball bearing 6002 2RZ Precision ball bearing 6002 2RZ stainless steel
Material	
Inner tube	Zinc-plated steel or stainless steel
Tapered elements	Polypropylene (grey) on a cylindrical inner tube made of zinc-plated steel / stainless steel with an external diameter of 50 mm
Shaft	Uncoated steel or stainless steel
Bearing	Bearing housing made of polyamide (black) Bearing seal made of polypropylene (yellow) End cap for the side with the largest diameter made of polypropylene (yellow)

Drives Combinable with Tapered Conveyor Rollers

Drives can be combined with an internal curved radius of 800 and 850 mm (or 770/820 mm when the drive head is on the internal radius), providing nothing else is specified. The internal radius of the curve is measured to the internal edge of the internal bearing profile, that is to the beginning of the installation length EL.

The following drive elements are available:

- PolyVee drive head made of high-grade polyamide 6.6 form PJ, ISO 9981, for flexible PolyVee belts



- Round belt head made of high-grade polyamide 6.6 for standard round belts with a diameter of 4, 5 and 6 mm, optional grooving on the extended inner tube on the internal radius of the curve



Drive elements

CURVES

- Double sprocket head made of high quality polyamide 6.6 with 14 teeth, measuring 1/2" on the external radius of the curve



Calculating the installation length (PolyVee/round belt head)

The installation length of curved sections must be longer than that of straight sections to ensure that the material to be transported does not touch the side profiles in the curve. The following steps are necessary to calculate the minimum installation length:

1. Calculate the minimum external radius

$$R_a = 50 \text{ mm} + \sqrt{(R_i + W)^2 + (L/2)^2}$$
2. Calculate the minimum installation length $EL_{\min} = R_a - R_i$
3. Adjust the EL_{\min} to standard length (next higher dimension in increments of 50 mm):
 - From 286 to 936 mm for curves with PolyVee or round belt heads
 - From 312 to 962 mm for curves with 2 sprockets
 - from 250 to 900 mm for non-driven curves
4. Calculate the actual $R_a = EL + R_i$ with the standard EL selected

Calculating the roller pitch on the external diameter

The roller pitch T_a is measured on the internal edge of the external profile and is calculated as follows:

$$T_a = T_i \cdot R_a / R_i$$

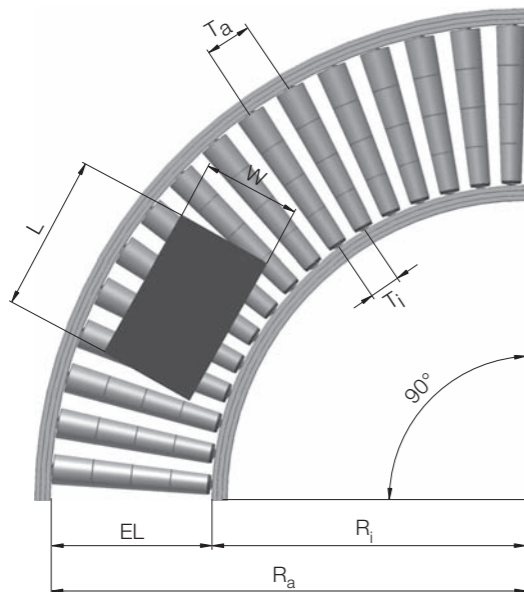

EL	Installation length of the conveyor roller
L	Maximum length of material to be transported
W	Maximum width of the material to be transported
R_a	External radius of the curve
R_i	Internal radius of the curve
T_a	Roller pitch on the external diameter
T_i	Roller pitch on the internal diameter

Internal radius of curve for non-driven roller curves

The internal radius of the curve depends on the length of the roller and is:

- 800 mm with a reference length of 300, 400, 500 mm etc.
- 850 mm with a reference length of 250, 350, 450 mm etc.

Calculating the internal radius of the curve for driven roller curves (PolyVee/round belt head)

The internal radius of the curve depends on the length of the roller and is:

- 770 mm with a reference length of 300, 400, 500 mm etc.
- 820 mm with a reference length of 250, 350, 450 mm etc.

Using a RollerDrive as the drive for driven roller curves has established itself as the most cost-effective and attractive of all drive solutions. Curves with a RollerDrive combined with the aforementioned tapered conveyor rollers are silent, compact and have a simple design.

The average diameter of the tapered elements must be used to calculate the necessary torque and conveyor speed when RollerDrive is used as the drive.

Internal curve radius

RollerDrive

CURVES

PolyVee torque transmission

Only flexible PolyVee belts with three ribs combined with Fixed Drive Rollers Series 3500 and PolyVee drive heads can be used as torque transmission.

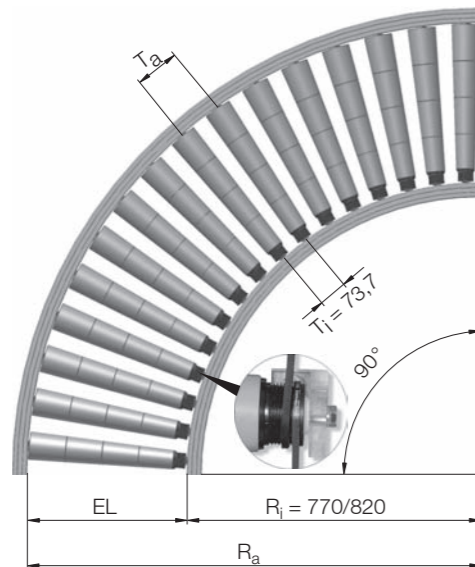

The projected drive head (RL = EL - 36 mm) produces internal curve radii of 770 and 820 mm.

When PolyVee belts (2-ribbed) are used, the roller pitch on the internal radius is defined as $T_i = 73.7$ mm. If this roller pitch is not feasible, a drive with a round belt or chain will have to be selected.

Round belt torque transmission

The pitch for round belt drives and for non-driven curves can be selected at will providing the following conditions are adhered to:

- Safe conveyance of the material to be transported
- No contact between the tapered elements
- First and last conveyor roller has approx. half of the roller pitch (internal radius) at the end of the curve
- Possible standard belt lengths are taken into account

Torque transmission with chains

Using a chain as a drive medium only allows a limited number of roller pitches, which always have to be a multiple of the chain pitch of $\frac{1}{2}$ ". Chain drive is only feasible in a curve using the roller-to-roller method. The pitches from conveyor roller to conveyor roller on the internal and external radius must be calculated individually according to the length and pitch of the roller.

The calculation of the pitch spacings always begins at the external radius in order to guarantee the correct chain tension. Please note when doing so that the sprockets in contact change from roller to roller (internal/external sprocket) and that the pitch only repeats on every second roller. The pitch on the internal radius is determined by the respective reference length .

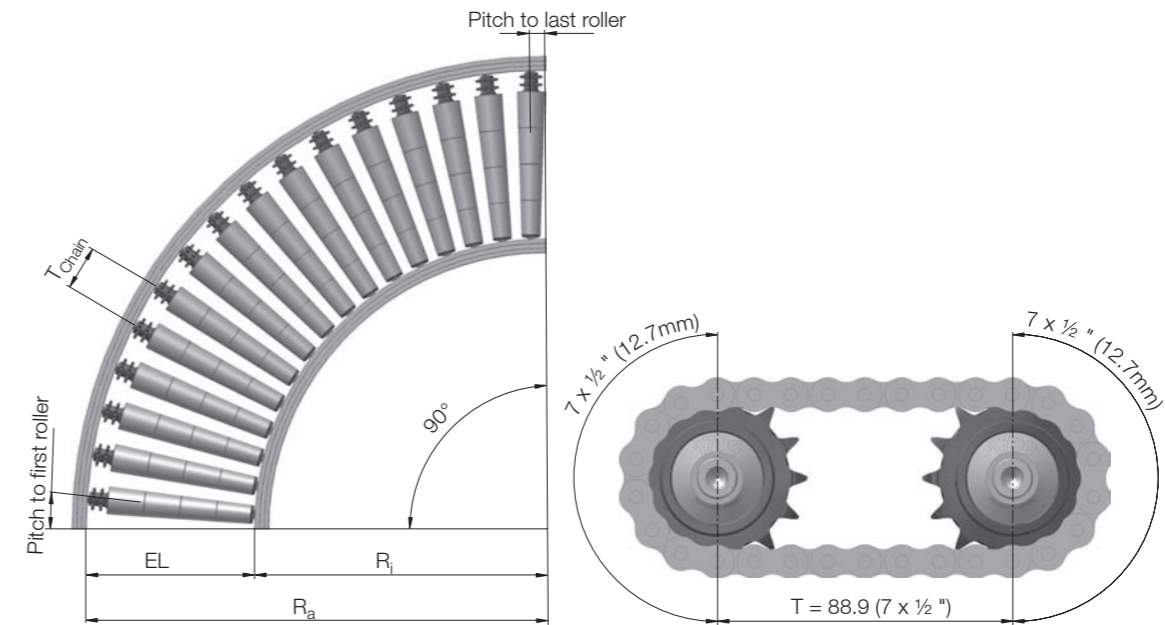

The following theoretical pitches (measured on the sprocket Z14) have proved themselves in practice:

Number of chain links	Pitch measured on the sprocket mm
28	88.9
30	101.6
32	114.3
34	127.0
36	139.7
38	152.4

The number of conveyor rollers changes according to the length and, thereby, the greater radius on the external radius.

The following information on the number of conveyor rollers required relates to a 90° curve on which a projection to the 90° angle of the side profile has been designed in for equalisation.

Reference length in mm	Chain pitch in mm					
	88.9	101.6	114.3	127.0	139.7	152.4
250/300	19	16	14	13		
350/400	20	18	16	14	13	
450/500		19	17	15	14	13
550/600		21	18	17	15	14
650/700			20	18	16	15
750			21	19	17	16
800				19	17	16
850/900				20	18	17

ROLLERDRIVE AND DRIVECONTROLS

RollerDrive

The RollerDrive is based on the Universal Conveyor Roller series 1700. Its external dimensions are identical. Conveyor installations can therefore be designed more simply with RollerDrive than with conventional AC drives.

The RollerDrive also has the benefits of the Universal Conveyor Roller Series 1700 and its different versions, e. g. the same drive heads are used on the RollerDrive. This drive is ideal for integrating into installations.

RollerDrive in operation

The excellent flexibility of conveyor designs using RollerDrive is supported by the design of the controller software and hardware. RollerDrive can be integrated into a number of existing or new installations using universal interfaces.

Electronically and mechanically commutated electric motors form the very heart of the RollerDrive. RollerDrive are extremely quiet owing to the reliable vibration decoupling of the drive unit. This decoupling protects the gears from impact stress. This protection minimises stress on the tooth bases of the gear wheel and thus extends the service life of the RollerDrive.

The motor is coupled to a planetary gear box. The planetary gear box has one to three stages and different reductions. The torque is reliably transmitted to the cylindrical roller sleeve by means of a coaxial compression tube coupling. The RollerDrive is mounted on two bearing housings, which are pressed into the roller sleeve opposite each other. The bearing housings come from the standard parts range or are derived from this.

Planning using RollerDrive

Please consult your Interroll customer consultant for the RollerDrive ideal for your application. The following factors are critical in offering the correct solution:

- Weight and dimensions of the material to be transported
- Conveyor speed, throughput and cycles per minute
- Material on the underside of the item to be transported (determines the coefficient of friction of the roller)
- Special ambient conditions, such as extremes of temperature, humidity, chemical effects etc.
- Type of RollerDrive control
- Maximum over run of material to be transported

The over run is the distance, which the transported items will travel once the start signal has been cancelled due to its mass inertia on the conveyor.

Electrostatic protection

The bearing housings of the RollerDrive are made of conductive polymer. This conducts electrostatic charge into the side profile. It is imperative that the entire conveyor is properly grounded.

Selecting the conveyor speed

In the first step, the conveyor speed is selected using the gear speed, ensuring that a maximum of power is always available. In the second step, fine adjustments can be made using the controller.

Load capacity of the RollerDrive

Usually it is not the load capacity that limits the conveyor options but rather the maximum torque of the RollerDrive.

RollerDrive correspond statically to conveyor rollers without continuous shafts with fixed shaft pins. The torque is

transmitted only on the fixed motor side.

The RollerDrive must be fixed and able to withstand the following starting torque:

RollerDrive	Starting torque of the fixing nut
BT 100	40 N/m
EC 310	35 N/m
EC 310 IP66	35 N/m

The side opposite the motor can have an 11 mm hex spring-loaded shaft or an M8 shaft pin.

For safe and reliable conveyance, at least one RollerDrive and two conveyor rollers without their own drives, so-called idlers, have to be located under the material to be transported.

A calculation program for the load capacity can be downloaded on the Interroll website www.interroll.com. The shaft type has to be specified as **Round** and the shaft location as **Stub Axle** in the program.

The tube material is principally 50 x 1.5 mm.

The following section presents examples and basic correlations for calculating the output.

If the item to be transported is to be moved on a conveyor perpendicular to the direction of the roller shaft, that is free of transverse force, then the static friction and rolling friction have to be overcome.

The following equation applies to materials to be transported, which are moved at a constant speed along a conveyor track:

$$F = m \cdot g \cdot \mu$$

F	Required tangential force in N
m	Mass in kg
g	Gravitational acceleration 9.81 m/s
μ	Coefficient of friction

Sample calculation:

Weight of the material to be transported	30 kg
Containers	Polymer box, coefficient of friction $\mu = 0.04$
Speed	0.5 m/s

$$F_t = 30 \text{ kg} \cdot 9.81 \text{ m/s} \cdot 0.04 = 11.77 \text{ N}$$

The required tangential force is thus 11.77 N. A roller radius of 25 mm thus requires a torque (Force x Distance) of 0.3 N/m. The required mechanical output (Force x Speed) is 5.9.

Calculating the roller resistance and output

ROLLERDRIVE AND DRIVECONTROLS

Coefficient of friction for container materials:

Material	Coefficient of friction μ
Steel	0.03
PVC, smooth	0.04
Polymer, profiled	0.05
Wood	0.05
Cardboard, rigid	0.06
Cardboard, soft	0.08

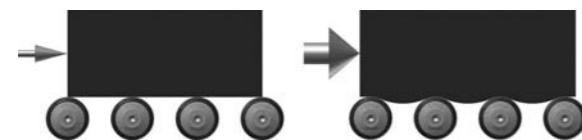

The required drive force to convey an item at a constant speed along a conveyor track depends on the material and condition of its underside. A minimal force has to be exerted for a rigid, difficult to deform underside, such as a steel container.

A steel container tends, however, towards slippage on the tube sleeve when accelerating and slowing down. Approx. 3 % of the weight of the material is applied as propelling force during constant travel. μ is approx. 8 % with a cardboard container. This can be explained by the soft and malleable underside. With a cardboard container, the differential figure is applied to the steel container for the deformation of the underside of the container and is therefore no longer available for the forward motion.

As a conveyor cycle consists of acceleration, constant travel and braking, acceleration is critical for assessing the output.

In the acceleration phase, the static friction is overcome and a transition to significantly lower roller friction takes place. For this reason a power surge can be witnessed at the start of every conveyor cycle.

DriveControls for RollerDrive

Conveyor sections can be controlled in two ways: centrally controlled or by means of decentrally distributed logic. Interroll has systems for both approaches to ensure the extremely flexible use of RollerDrive.

Motor and zonal control

A differentiation is made between two types of controller:

- DriveControl (I/O-based motor starter)
- ZoneControl (decentralised conveyor logic)

The ZoneControl is used for simple, I/O-based control of the RollerDrive. The ZPA Controller enables the very straightforward set-up of a zero pressure accumulation conveyor and incorporates the functions of the DriveControl.

The RollerDrive BT100 does not require an external controller. An integral thermal element switches off the RollerDrive in the event of it overheating and switches it on automatically when it has cooled down. This does not constitute complete protection from overloading but is rather basic protection.

The DriveControl is the ideal control for the RollerDrive EC310. Protection classes IP20 and IP54 are achieved by the use of two different housing designs. The IP54 version of housing is moulded.

All inputs and outputs have their own common signal mass and are therefore separated from the load current mass. The voltage supply can be looped from one DriveControl to the other to simplify cabling (max, 2 DriveControls linked).

The speed of the RollerDrive can be adjusted in two different ways using the DriveControl: On the one hand using a DIP switch. There are four DIP switches available that permit 15 different speeds. On the other hand from outside, by means of three digital inputs, with which eight different speeds can be set. It is thereby possible simply and easily, for instance with two digital PLC outputs to set and dynamically change two different speeds during operation.

The ZoneControl enables a self-controlling zero pressure accumulation conveyor to be set up. Every zone and thus every RollerDrive is connected to a ZoneControl. The individual ZoneControls communicate with each other via CAT5 standard network cables. This cable is available worldwide in different lengths and guarantees excellent connection quality. It is effectively the cable that is used in IT for ethernet connections and it can also be installed quickly and safely.

Two sensors can be connected: a zone sensor in each zone and also a start sensor at the start of the conveyor system. The speed and direction of rotation can be set by means of DIP switches at each ZoneControl and this only affects the individual RollerDrive. An analogue target value input (0 to 10 V) is also available if the speed of the entire conveyor system is also dynamically adjusted during operation. The speed can also be adjusted by means of an analogue PLC output.

A status signal and a start input are available to fit the ZoneControl conveyor system into an existing layout. The configuration of the zone sensor can be tapped externally on the status signal. The start input can be used to start the first and/or last zone of the conveyor. This ensures the transition of the materials being conveyed. The zone status and start signal constitute the "handshake I/Os" of the upstream and downstream systems.

It is possible with especially heavy materials that require two RollerDrive as zone drives, to control a second RollerDrive by means of the DriveControl of the ZoneControl. A system-wide error signal reports error functions as a group message. The error can be localised by an error LED and be analysed by different flashing frequencies.

MATERIAL SPECIFICATION

Tubes

Material	Standards	Specification
Uncoated steel and zinc-plated steel	DIN EN 10305-3	Limited tolerances and material specifications by Interroll
Zinc plating	DIN EN 12329 DIN 50961	Galvanized zinc sleeve with additional blue passivation (chromium IV-free) Sleeve complies with RoHS regulations Layer thickness 6 to 15 µm
Stainless steel	DIN 17455	1.4301 (X5CrNi18-10) Limited tolerances by Interroll
Aluminium	–	AW 6060 T66 (AlMgSi 0.5 F22) For 16 mm and 20 mm E6/EV1 , stained, natural and anodised Surface layer thickness 20 µm, isolating and non-conductive For 50 mm mill-finished, unfinished, thus conductive
PVC	2002/95/EC	PVC-U (rigid polyvinyl chloride, softener-free, silicon-free, highly impact-proof) Contains only materials, which have been tested and registered to comply with the REACH Directive (EC No. 1907/2006) Dust grey, RAL 7030

For concentric tolerances refer to p 208

Bearing

Precision ball bearings, lubricated (6002 2RZ, 6003 2RZ, 6204 2RZ, 6205 2RZ, 689 2Z)

Standard	DIN 625
Material	Rings and balls are made of stainless steel of material grade 100Cr6 Hardness: 61 ± 2 HRC, with metal cages
Bearing play	C3
2RZ Seal	Non-grinding 2-lip seal with labyrinth effect manufactured from steel-reinforced acrylonitrile-butadiene rubber (NBR)
2Z Seal	Non-grinding cover discs made of sheet steel
Lubrication	Multi-grade grease, silicon-free
Temperature range	-30 °C to +177 °C

Precision ball bearing, lubricated (6002 2RZ)

Standard	DIN 625
Material	Rings and balls are made of stainless steel of material grade 100Cr6 Hardness: 61 ± 2 HRC, with metal cages
Bearing play	C3
2RZ Seal	Non-grinding 2-lip seal with labyrinth effect manufactured from steel-reinforced acrylonitrile-butadiene rubber (NBR)
Lubrication	Multi-grade oil, silicon-free
Temperature range	-30 °C to +80 °C

Precision ball bearings made of stainless steel, lubricated (6002 2RZ)

Standard	DIN 625
Material	Rings and ball made of stainless steel, material 1.4125 (X105CrMo17), with a material grade to comply with AISI 440C Hardness: 56 ± 2 HRC, with polyamide cages
Bearing play	C3
2RZ Seal	Non-grinding 2-lip seal with labyrinth effect manufactured from steel-reinforced acrylonitrile-butadiene rubber (NBR)
Lubrication	Multi-grade grease, silicon-free
Temperature range	-30 °C to +177 °C

Steel cone bearing 50 x 1.5 , lubricated

Material	Wheel body material DX53D + Z, zinc-plated Bearing parts, hardened
Lubrication	Multi-grade grease, silicon-free
Temperature range	-30 °C to +110 °C

Polymer bearing

Material	External ring and cone made of polypropylene Balls made of carbon steel or stainless steel
Lubrication	Multi-grade grease, silicon-free
Temperature range	-30 °C to +40 °C

MATERIAL SPECIFICATION

Shafts

Material	Standards	Specification
Uncoated steel and zinc-plated steel	DIN EN 10277-3	1.0715 (11SMn30) Limited tolerances and material specifications by Interroll
Zinc plating	DIN EN 12329 DIN 50961	Galvanized zinc sleeve with additional blue passivation (chromium IV-free) Sleeve complies with RoHS regulations Layer thickness 6 to 15 µm
Stainless steel	DIN EN 10088-23	1.4305 (X5CrNi18-9) Limited tolerances by Interroll

For concentric tolerances refer to p 208

Drives

The technical data on the Interroll PolyVee belt is outlined in the following section.

Please contact the relevant manufacturer for information on all other drives.

Standards	ISO 9982 (DIN 7867) profile PJ for 2- and 3-ribbed V-ribbed belts (PolyVee)
Material	Complies with the 2002/95/EC (RoHS) Directive Contains only materials, which have been tested and registered to comply with the REACH Directive (EC) No. 1907/2006 Halogen-free, silicon-free, PVC-free, flame-resistant
Certification	UL-certified
Hardness	Rear 82 Shore A, Ribs 55 Shore A
Electrical conductivity	< 7 MΩ
Temperature range	-20 to +90 °C
Dimensions	In accordance with ISO 9982 (DIN 7867) profile PJ

PolyVee Belts

MATERIAL SPECIFICATION

Technical Polymer

Benefits Interroll uses parts made of polymer in almost all conveyor elements. Polymer has many advantages over steel:

- Sound reduction
- Limited food-compatibility
- Easy to clean
- Excellent impact strength
- Corrosion resistance
- Lower weight
- High quality design

Properties and applications

Polymer	Properties	Uses
Polyamide (PA)	<ul style="list-style-type: none"> • Outstanding mechanical properties • Excellent wear resistance • Low coefficient of friction • Good chemical resistance 	Sprocket heads, seals and bearing seats
Polypropylene (PP)	<ul style="list-style-type: none"> • Low specific weight • Excellent heat resistance • Not hygroscopic • Good chemical resistance 	Wheels, seals and bearing seats
Polyvinyl chloride (rigid PVC)	<ul style="list-style-type: none"> • Scratch-resistant • Impact-resistant • Good chemical resistance 	Tubes for polymer conveyor rollers
Polyoxymethylene (POM)	<ul style="list-style-type: none"> • Outstanding mechanical properties • Excellent wear resistance • Low coefficient of friction • Very dimensionally stable • Minimal absorption of water • Used on parts which require a very high level of precision 	Toothed belt heads and slide bearings

Resistance Polymer is sub-divided according to its chemical resistance:

Symbol	Meaning	Explanation
++	Very good resistance	Continuous exposure to the medium causes no damage
+	Generally resistant	Continuous exposure to the medium can cause damage, which is reversible when no longer exposed to the medium
-	Mostly non-resistant	Only resistant if there are optimum ambient and application conditions but generally some damage is to be expected
--	Completely non-resistant	The medium may not come into contact with the polymer

The information given in the following tables is intended only as a guideline, as many factors can have an effect on a plastic's resistance including

- Duration of exposure and concentration of the medium
- Temperature
- Exposure to force
- UV exposure

A thorough suitability test of the polymer to be used by the user is indispensable.

	Polyamides	POM (polyoxy-methylene)	Soft PVC	Rigid PVC	Polypropylene
Ethers	++	++	-	++	-
Alcohols, lower	++	++	++	-	++
Petrol	++	+	--	++	-
Esters	++	--	--	--	-
Fats	++	++	-	++	+
Hydrofluoric acid	--	--	-	-	-
Ketones	++	-	--	--	++
Hydrocarbons, aliphatic	++	++	--	++	++
Hydrocarbons, aromatic	++	+	--	--	-
Hydrocarbons, chlorinated	-	++	--	--	--
Hydrocarbons, unsaturated, chlorinated	+	++	--	--	--
Brine, weak	+	++	++	++	++
Brine, strong	-	++	-	++	++
Mineral oil	++	++	-	++	-
Oils	++	++	-	++	+
Acids, oxidising	--	--	-	--	--
Acids, weak	--	-	++	++	++
Acids, strong	--	--	++	-	--
Acids, strong, organic	-	++	-	+	++
Saline solutions, inorganic	++	++	++	++	++
Turpentine	-	-	--	--	--
Fuel mixture	+	++	--	--	-
Water	++	++	++	++	++

INTERROLL CENTRE OF EXCELLENCE- CONVEYOR ROLLERS



The Interroll Centre of Excellence in Wermelskirchen (near to Cologne, Germany) concentrates on conveyor rollers, RollerDrive and controls, used as key products in roller conveyors for container transport and other internal logistics systems. In this product sector, the company certified in compliance with ISO 9001 is responsible within the global Interroll Group for all technical concerns ranging from development and application engineering to production and support for local Interroll companies. With an annual production volume of several million units, Interroll is currently seen in the logistics sector as the world's largest specialist manufacturer of conveyor rollers.

Interroll Engineering GmbH
Höferhof 16
42929 Wermelskirchen, Germany

+49 2193 23-0



Inspired by efficiency

Established in 1959 Interroll has grown to become the world's leading supplier of key products for internal logistics. Whether boxes, pallets or soft goods are to be handled, no other supplier has such a complete product range on offer. That is why system integrators, OEMs and operators select Interroll as their partner for their internal logistics business. Worldwide. The Interroll global network ensures quick delivery and superior service for every local customer. We inspire our customers and provide opportunities for them to increase efficiency.

Interroll Holding AG

P.O. Box 566
Via Gorelle 3
6592 Sant'Antonio
Switzerland
Tel. +41 91 850 25 25
Fax +41 91 850 25 55

interroll.com

Interroll reserves the right to modify the technical characteristics of all its products at any time. Technical information, dimensions, data and characteristics are indicative only.
© Interroll 2016